

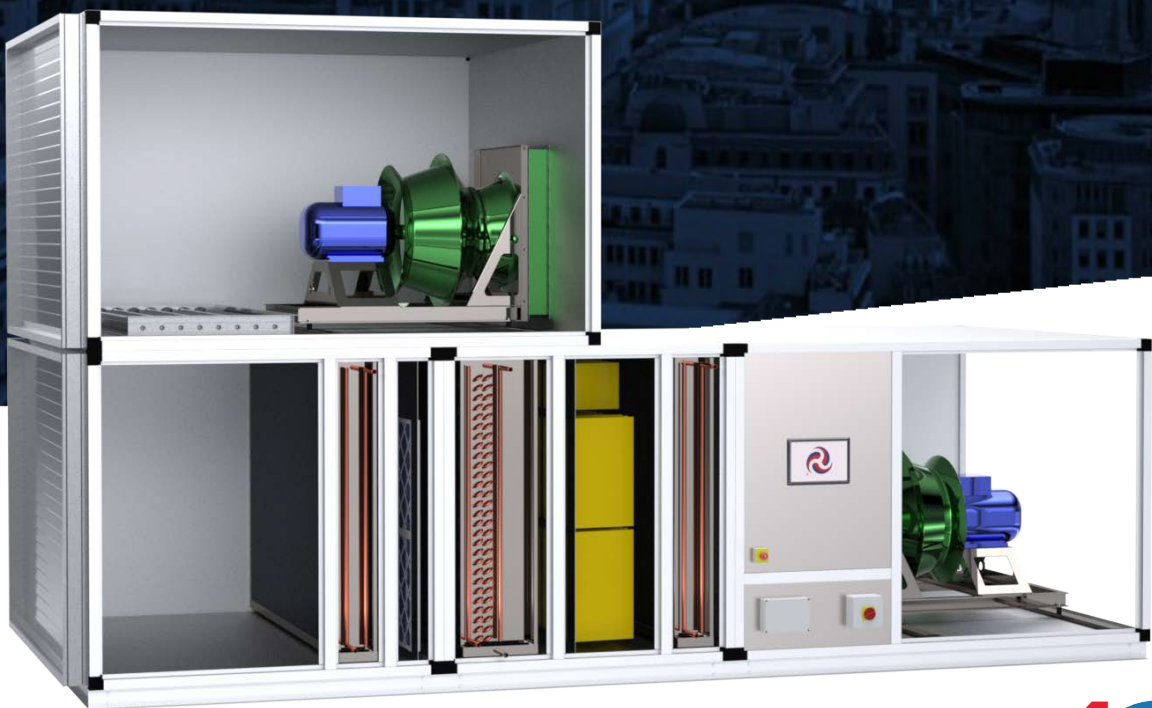

# Supply and Extract Unit 3-Way Mix SEU3MX

Original Instructions Air Handling Units  
Installation, Operations and  
Maintenance Manual



2024 Release

ECE UK LTD Pharaoh House, Arnolde Close, Rochester, Kent. ME2 4QW



## Purpose

This manual contains advice for installers and users.

General information about the range, construction and selection of ECE air handling/conditioning equipment can be obtained from our website, various sales publications, or by telephone.

Certified individual unit data concerning dimensions, weights, component specification and performance, is issued with the order acknowledgement for each unit.

Due to our policy of continuous improvement the information contained within this Manual may be altered from time to time without prior notice.

## Table of Contents

SEU3MX Principle and Operation .....	8
Application .....	9
Operation .....	9
Ancillary Items.....	9
Checks at Design Stage.....	10
Air Inlets and Discharges .....	11
Acoustics – Vibration.....	13
Services – Connections .....	13
Commissioning & Fault Finding.....	13
Maintenance Repair and Renewal .....	14
General .....	14
Copra Minimum and Recommended Clearances.....	15
Checks at Order Stage.....	16
Delivery .....	19
Receipt & Unpacking .....	20
Fan Transport inspection .....	21
Fan Intermediate storage.....	21
Copra Transport.....	22
Transport Damage .....	22
Transport Safety .....	22
Copra Attachment Points.....	23
COPRA Plug Series.....	23
COPRA Core Series .....	23
Copra Temporary Storage .....	24
Lifting .....	25
Crane - Long lifting straps (150mm min. width) .....	25
Crane – “H Frame” Short lifting straps (150mm min. width).....	25
Lifting – With Base Frame Lifting Holes .....	26
Crane - Long lifting straps (150mm min. width) .....	26
Crane – “H Frame” Short lifting straps (150mm min. width).....	26
Forklift .....	27
Rollers.....	27
Skates .....	27
Toe Jacks.....	28
Installation .....	29
General .....	30
Hinged Handle Access .....	30
Compression Latch-Hinge .....	31
Bases and foundations .....	33
Plug Fans.....	35
Fitting the Accessories.....	35
Electrical Connections .....	35
Electric Heater Battery .....	36
Controller Specifications .....	36
Installation .....	40
Troubleshooting .....	41
BMS.....	42

---

BMS Open or Closed Loop .....	43
Wiring Diagrams .....	44
Copra Installation .....	46
Safety Instructions .....	46
Installation Location .....	46
Installation And Mounting .....	46
Mounting Instruction .....	47
Recommended Distances .....	47
Copra Electrical Connection .....	48
Safety Instructions .....	48
EMC Compliant Installation .....	48
Mains Connection & Connection Plan .....	49
Overview Supply Connections .....	49
Supply Connections .....	49
Control Connections .....	50
RLM Installation .....	51
Electrical Connections .....	51
Safety Notes .....	51
Connections to the grid .....	52
Motor Protection .....	52
Motor Starting .....	52
Supply and Extract Unit Fan Type & Speed Control .....	53
Copra Information .....	54
Important Information .....	54
Operating Instructions .....	54
Safety Instructions .....	54
Copra Technical Description .....	55
Specifications .....	55
Intended use .....	55
Improper use .....	56
RLM Technical Information .....	57
Product Description .....	57
Technical Data .....	57
Authorised use .....	58
Improper Use .....	58
Important Information .....	59
Operating Instructions .....	59
Trend - VSD2H Variable Isolator Speed Drives .....	60
VSD2H Variable Isolator Speed Description .....	60
VSD2H Variable Isolator Speed Features .....	60
Physical (dimensions in mm) .....	61
Functionality .....	62
Hardware .....	63
DIP Switch .....	69
Quick setup .....	70
Monitoring .....	70
Parameters .....	70
Diagnostics .....	70
I/O and hardware .....	70
User settings .....	70
Favourites .....	70

---

---

Digital Input Isolation.....	70
Ethernet Connection .....	71
RS485 Connection .....	71
Real Time Clock .....	71
Integrated RFI-filter.....	72
Integrated DC Choke.....	72
Integrated Stress Removal .....	72
External Keypad .....	72
ACC/VSD2H/Hand Held Kit.....	73
ACC/VSD2H/Door Mounting Kit .....	73
Hardware.....	74
Quick Setup.....	76
Uninterruptible Operation and Energy Saving.....	76
VFD and Motor Control .....	77
Software .....	78
SISO – Safety Isolators/Switch-disconnectors .....	79
Switches & Sensor .....	79
Features .....	79
Description .....	79
Range.....	80
Commissioning .....	81
Plug / SISW / DIDW Fans - Motors – Drives .....	82
Belt Drives.....	82
Anti-Vibration Mountings.....	84
Rubber Mountings.....	84
Spring Mountings.....	85
Selection Table.....	85
Checking Label Positioning .....	86
Hinged Handle Access .....	86
Compression Latch-Hinge .....	87
Servicing Filters .....	89
Mixing Boxes – Separation Boxes - Shut off VCD's - HRD's .....	90
Coils.....	90
Coil Connections .....	91
Setting Water Flow through Coils .....	91
Coil Condensate Drains.....	92
Draw Through Units and Blow Through Units with negative pressure (depression at trap) .....	92
Blow through units with positive pressure at trap .....	93
Blow Through.....	95
Draw through coils with condensate pump .....	96
Mixing circuit using three-way mixing valves. ....	97
Chilled Water Cooling Coils .....	98
Hot Water Heating Coils.....	99
Steam Coils.....	100
Electric Heater Batteries.....	101
Gas Fired Heaters .....	102
Electronic Steam Humidifiers.....	104
Coproa Commissioning .....	105
Test Run .....	105
Check The Power Consumption .....	105
Check For Smooth Running.....	105

---

---

Volume flow measurement device .....	105
Operating Modes.....	106
Analogue Control (analogue input signal).....	107
PWM (PWM input) .....	108
Modbus operation .....	109
Self Protective Function of The Electronics .....	109
Non UL - Over Voltage .....	110
Non UL - Under Voltage .....	110
Non UL - Over Temperature .....	110
Non UL - Over Temperature .....	110
Non UL - Utility supply power input phase .....	111
UL - Locked Rotor .....	111
UL - Loss of Motor Phase .....	111
Non UL - Derating.....	111
UL - Over Load .....	112
UL - Hardware Faults.....	112
RLM Commissioning.....	113
Safety Checks .....	113
Test Run .....	113
Checking the current consumption.....	113
Check for quiet running.....	113
Flow measuring device .....	114
Commissioning fans with frequency inverters .....	115
Instructions for fans with PM motors on external frequency inverters .....	115
Commissioning fans with integrated Danfoss FCP-106 frequency inverters.....	115
Commissioning fans with integrated NI-DV inverters .....	116
Connection.....	116
Frequency inverter activation options .....	116
Maintenance.....	117
Lifting of the Fan Motor .....	118
Lifting Beam .....	118
Working Load Limit.....	118
Installation of Lifting Beam is Permanently Mounted .....	118
Operation.....	119
Checks Prior To Use .....	119
Safety Instructions .....	119
Copra Maintenance and Repairs .....	120
Safety instructions .....	120
Maintenance intervals.....	121
Vibrations .....	121
Impeller mounting .....	121
Spare parts.....	121
Breakdowns/malfunctions .....	122
Recycling and Disposal.....	122
Disassembly .....	122
Component Disposal and Recycling.....	122
RLM Fan Maintenance .....	123
Safety Notes .....	123
Inspection Intervals .....	124
Vibrations .....	124
Dismantling of the impeller.....	124

---

---

Inlet and discharge connections .....	125
Faults.....	125
Disposal of the product .....	125
Maintenance Schedule .....	126
SISW / DIDW - Fan Bearings.....	128
Spider Arm Bearing .....	128
Plummer Block Bearing .....	129
Replacing the filters (for HTM specification units).....	130
Motor Bearings .....	132
Motors without Grease Points.....	132
Motor Overheating .....	132
Washable Filters .....	132
Activated Carbon (Constantly Monitored).....	132
Activated Carbon (disposable non-monitored).....	132
Electric Heater Batteries.....	133
Dampers - Motors .....	133
Coils - General .....	133
DX Cooling Coils.....	133
Fault Finding .....	134
Copra Troubleshooting Guide .....	135
Fault Indication – LED Blink Codes .....	135
Centrifugal Fans.....	136
Electric Heaters.....	137
Cooling Coils .....	137
Heating Coils .....	139
Refrigeration.....	139
Fan Drive Belts.....	140

## SEU3MX Principle and Operation



## Application

Air handling units incorporating 3 way mix or air-mixing plenum are important elements in saving energy in Distribution Centres, Warehousing, Pharmaceutical and Data Centres or where the Air Handling Unit intended use is in a building or part of a building not designed for human occupancy as clarified under Ecodesign Commission Regulation (EU) No 1253/2014. If the product is not designed for replacing utilised air with outdoor air, it is not a ventilation unit, unless the same product is also designed to replace only utilised air, and thus it should comply with all relevant requirements of the Ecodesign measure. In case the product has a connection to the outdoor with a supply / exhaust air flow rate in regular operation of minimum 10% of the total declared recirculated air flow rate, the unit is considered a ventilation unit and falls under Regulation 1253/2014.

## Operation

The AHU air-mixing plenum combines two air streams and it is common for the supply and extract air handlers to be joined together, either in a side-by-side or a stacked configuration. The configuration includes three sets of dampers: one for the fresh air, one for the exhaust air, and a mixing damper between the two air streams. The mix of fresh air and recirculated air can thus be adjusted to suit the needs of the building. Typically as the fresh air and exhaust air dampers are driven from 0% open to 10% open, the mixing damper will in turn be driven from 100% open to 90% open, so as to always ensure a constant volume of supply and extract air.

## Ancillary Items

Air filtration is always present in order to provide clean dust-free air to the building. Direct heating, placed directly in the air stream, are direct heat exchangers and include those for gas-fired fuel-burning heaters or electric air heater batteries (EAHB). Indirect Heating and Cooling coils use hot water or steam for heating, and chilled water for cooling. Heat pumps can be used as well. (Prime energy for heating and cooling is provided by central plant). Humidification is often necessary in colder climates where continuous heating will make the air drier, resulting in uncomfortable air quality and increased static electricity. Various types of humidification may be used as part of our air handler and include evaporative, vaporizer, spray mist and wetted medium. If dehumidification is required, then the cooling coil is employed to over-cool so that the dew point is reached and condensation occurs. A heater coil placed after the cooling coil re-heats the air to the desired supply temperature and humidity level. This is often used for chilled beam applications.

## Checks at Design Stage

### Air Inlets and Discharges

Whether ducted, or part of the Air Handling Unit, inlet and discharge connections to atmosphere such as Louvres, Cowls, Spigots, etc. should be located and dimensioned so that the flow restriction, short circulating, recirculation of vitiated air, pick up of contaminated air or nuisance discharge of exhaust air do not occur.

Ducted intakes and discharges to units should be designed and constructed to ensure that flow restriction, turbulence, pre rotation, jetting, uneven velocity profile and surface or object excitation do not occur.

Poor intake design causes uneven velocity profile across unit components resulting in moisture carryover hence flooding, design supply air conditions not being achieved, electric heater elements overheating, DX refrigerant cooling coils freezing and secondary generation of noise and vibration etc.

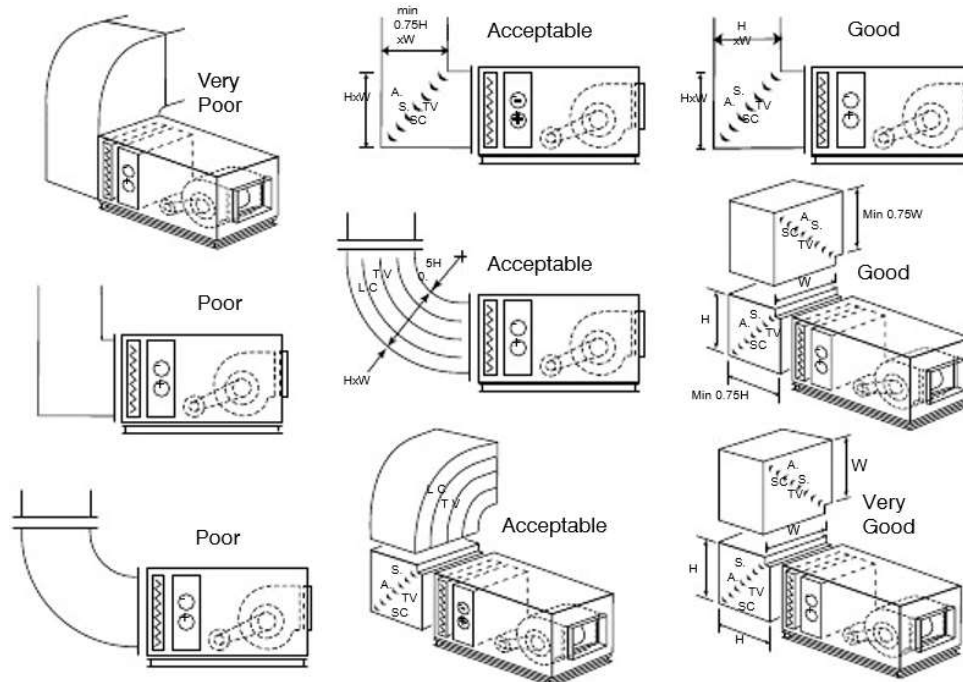

A.S. SCTV = Aerofoil Section Short Cord Turning Vane 50mm ctrs.  
LCTV = Long Cord Turning Vanes to HEVAC – CIBSE – ASHRAE Standards

Poor discharge design causes reduction in fan pressure and volume, also turbulence generating secondary noise and vibration, which may reduce impeller, bearing, isolator and flexible connection life. Design supply conditions may also be achieved. Electric elements may overheat. DX coils may freeze.

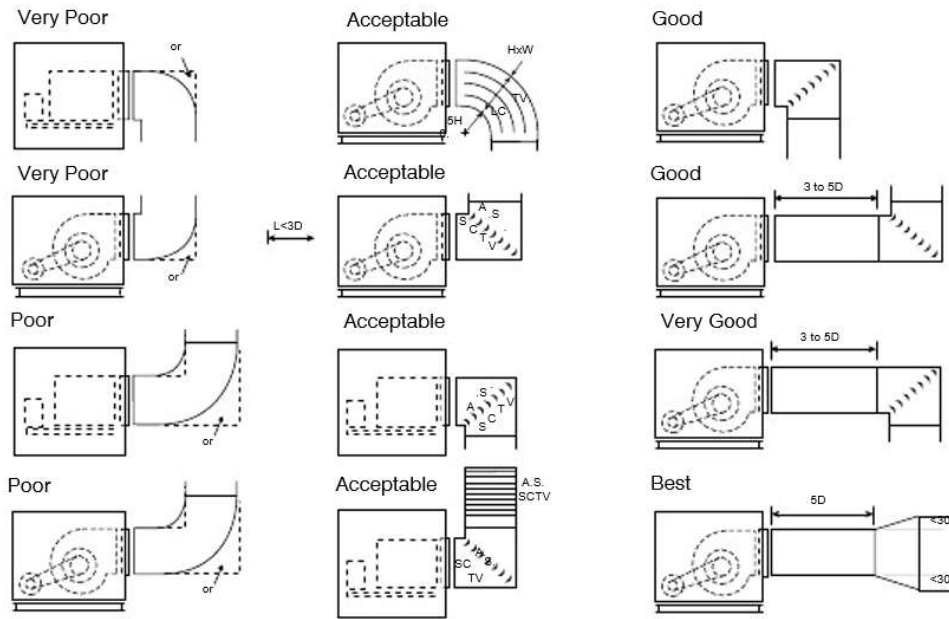

A.S. SCTV = Aerofoil Section Short Cord Turning Vane 50mm ctrs.  
 D = Fan inlet eye diameter  
 LCTV = Long Cord Turning Vanes to HEVAC – CIBSE – ASHRAE Standards

## Acoustics – Vibration

Ensure space exists for incorporating attenuation of the noise to atmosphere from outside air inlet and exhaust air discharge and on room side supply and extract ducts.

Consider noise from casing radiation, flanking and breakout.

Consider primary and secondary vibration isolation including service connections.

## Services – Connections

Ensure space with clearance exists for access to, routing of, connection to and expansion and contraction of water, steam, refrigerant, gas oil supplies and line fittings. Combustion air supply, flue gas exhaust. Venting of air, isolating and draining of plant, trapping and returning steam, condensate, trapping and draining of condensate from cooling coils, humidifiers and heat recovery devices to open tundish, blowing down waste to open tundish, pumping down and storing of refrigerant, power – control wiring, and components.

## Commissioning & Fault Finding

Ensure plant is designed to allow installation of and access to calibration and adjustment of measuring and modulating devices for:

- Air flow direction and rate
- Medium flow direction and rate
- Resistance to airflow
- Resistance to medium flow
- Air on and off dry bulb, wet bulb and humidity
- Medium on and off pressure and temperature

Ensure space exists in and around the plant for access to, inspection of, measuring of and work on items including:

- Belt tensioning of external motors
- Jacking and levelling of steel spring vibration isolators
- Clear sight of identifying labels measuring and recording devices
- VCD blades, links and actuators, humidifier generators, sparge pipes, coil and eliminator surfaces and drain pans, electric heaters, fan and drives
- Fan speed and direction of rotation
- Motor current, resistance, continuity
- Motor nameplate
- Terminal wiring diagrams
- Wiring

## Maintenance Repair and Renewal

For units with one piece coils ensure space exists of at least one unit width plus 150mm on the withdrawal side of each plant item. For units with split coils ensure at least half the width of the unit or 700mm whichever is greater.

Adjacent units can share the common space between them for access and withdrawal. Ensure room exists for safe working platforms where units are mounted at a high level.

Ensure provision exists for steps, ladders and mezzanine etc. Where units are over 1750mm high or mounted on platforms which elevate the unit height and make access difficult.

### General

Any or all of the following and their effect on the plant should be considered and the appropriate action taken:

- Conditions within surrounding areas
- External temperature and humidity
- Direct solar radiation
- Wind speed and direction
- Driven rain
- Driven snow
- Driven sand
- Sea spray, mist, fog, moisture in suspension
- Saline atmosphere
- Icing
- Unit surface temperatures and surrounding air dew point
- Gases which form acids in solution in water, such as SO<sup>2</sup>
- Flammability
- Explosion risk
- Toxicity
- Bacteria
- Fungi
- Algae

### Copra Minimum and Recommended Clearances

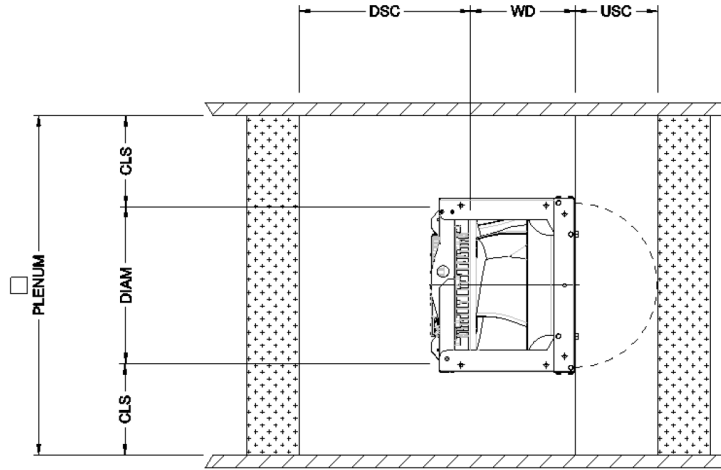

PFP ref.	Impeller Type	DIAM	DSC	USC	WD	Minimum		Recommended	
						CLS	Plenum	CLS	Plenum
C25	A	250	250	125	190	75	400	100	450
C28	A	280	280	140	210	84	448	112	504
C31	A	315	315	158	240	95	504	126	567
C35	A	355	355	178	265	107	568	142	639
C40	A	400	400	200	305	120	640	160	720
C45	A	450	450	225	335	135	720	180	810
C50	A	500	500	250	375	150	800	200	900
C56	A	560	560	280	420	168	896	224	1008
C63	A	630	630	315	TBA	189	1008	252	1134
C71	A	710	710	355	TBA	213	1136	284	1278

## Checks at Order Stage



### General Information

Date  
Time  
Contact(s)  
Company  
Address  
Phone  
Number Fax  
Number Email  
Address

### Contract Information

Customer Ref. No.  
Confidential? Job Name  
Delivery Area  
Specification Pages  
Other Standards Referred To In Spec  
Drawing No's.  
Schedule Reference  
Other Customer Documents

### Unit Information

Item No  
Area Ref  
Supply / Extract  
Int / Ext / Roof / Fitted Works or  
Site Part / Horiz  
Part / Vert  
Configuration / Sketch  
25mm - 50mm Panels

### External System Resistance

Depression at Unit Inlet  
Positive at Fan  
Discharge  
Pressurised Sep / Mix Box / Plenum  
Diffusion / Blanking Screen?  
One-Two-Duplex-Triplex  
DIDW - SISW  
FC / BC  
BD / DD  
Raft / Rigid  
I.G.V. + Controller  
NRD's One. Two.  
Guards:  
Inlet / Eyes / Disch / Drive

### Drives

Motors Int / Ext Duty / Idling  
Pulleys / Belts / In / Out / Air Stream  
1 Speed / 2 Speed / Variable  
Speed Spd Change Interlock with  
EAHB. Pole Change/Dual Wound.  
Electromagnetic Clutch  
(TASC) Switched Reluctance  
Inverter  
DOL / SD  
St' D/Fif  
Elec Supply  
Floor Grid  
Lifting Beams

### Filters

Presti.Stii  
St.I. 11.111.  
To Extract Heat Recovery  
Grease to Kitchen  
Extract Type  
Efficiency by Weight  
Efficiency Spot Dust  
Retentivity (Act. Carbon)  
BS. ASHRAE. Eurovent  
Withdrawal - Side / US / DS / T / B Fitted  
Manometer(s) Magnehelic(s)  
Radiant Heat from EAHB

### Inlets and Discharges

Louvres / FAI / DTA / Std / Acoustic  
Elmtrs + Drain High Velocity  
Fan Discharge 45° Spigot + Mesh

### Separation / Mixing Boxes / VCDs

Int / Ext Dampers  
FAI / RC / DTA Position  
Opp / Par / Man / Motor Belimo

### Volume Control

100% / Zone / F&BP / Location Int / Ext.  
Opp / Par / Man / Motor  
Construction GSS

### Heating / Cooling

Heat Recovery  
Heat Rejection  
Dehumidifying  
Humidifying  
Positon / Type  
Draw Through / Blow Through  
Volume M<sup>3</sup>/s  
Air On Cwb / Deb / Kg / Kg  
Air Off Cwb / Db / Kg / Kg  
Sweating Ins Frame  
Dx + Const Off = Freeze  
Humid Posn Adj Surfaces - Wetting  
Clear Distance Downstream  
Gas Heater. Condensation - Bypass  
Combst'n Air Inlet - Flue Output. Posn  
Load / Eff / Output  
Steps / Interplaced / Face  
Medium Type  
Flow Return °c  
Evap. Temp. °c  
Pressure - Bar / Kpa  
Glycol %  
Outside Ambient  
Cond. Temp. C  
Elec Supply  
EAHB Min Air Flow Speed  
EAHB Balanced Across 3ph Supply  
Interlock With Var.Sp.Fan.  
Construction

Plates / Tubes / Fins **Elements /**

### Burner / Infill

Finish: Self / Vinyl / Et.  
Free Cooling & Mechanical Top Up. Air  
Entering At 90° to Coil Face.  
Face Velocity Profile  
Condensate Drain Provision - Height

### Plenums

Location / Function  
Diffuser / Spacer / Access 90° / Horz / Vert  
To / From: Above / Below / LHS / RHS Hinged /  
Lift Off.  
Tool Op / Handles / Lock To One Handle  
Viewport(s)  
Bulkhead Light(s)  
Ext Switch  
Wiring by Others  
Floor Grids

### Inlet / Discharges

From: Above / Below / LHS / RHS / Face Louvre /  
Spigot  
Stack & Cowl  
90° + Sctv  
Grill / SD / DD / NV / OBDs  
Construction  
Finish

### Vibration Isolators

Int / Ext  
Eff Required %  
Rubber in Shear / Steel Spring  
Jacking  
Self-Levelling  
Fixed/Loose

### Flexibles

Isolating / Fan Raft / Fan Section  
Compute Unit / Pipe Connections  
Attenuating  
Flame Resistant  
Construction Finish  
Breakout  
Flanking

### Attenuators

Extract / Atmos / Room Side / Zone  
Supply / Atmos / Room Side / Zone  
To Achieve NR In / At  
Unit/Duct Mounted  
Straight /90 + SCTV  
Volume m<sup>3</sup>/s  
Inlet / Outlet Plenum / Length  
From / To / Above / Below / LHS / RHS / Face  
Finish  
Breakout  
Flanking

### Ancillaries

50 x 100 x 50 Full Perimeter Base  
6mm Anodised Aluminium  
3mm GSS Integral  
Lugs Support Legs  
Support Steelwork  
Side / Central Services Corridors  
Pipework  
Controls  
Wiring  
Access Platforms

### Construction

Frame / GSS / Ali / Plastisol Outer  
Panels / GSS / Plastisol Inner Skin /  
GSS / Plastisol St. St.  
Insulation 20mm / 50mm / 65kg / m<sup>3</sup>

### Finish

Location Ext / Int  
Anodised All Plastisol  
GSS Self

### Protection

Polystyrene Corners  
Cling Film Wrap  
Polystyrene Boards  
Rewrapped after Assembly

### Site Costs

Site Supervision Work Required  
Site Assembly Required  
Safety Checks I.E. Gas Heaters  
Guarantee Checks  
I.E. Assembly Standards, Weathering and  
Site Air Leakage Standards

### Problems

Transport: Loaded Vehicle Obstacle  
Clearance / Route Load Bearing  
Road Closure / Stat Permissions  
Onloading / Off Loading  
Crane, Fork Lift Weight / Capacity  
Moving On Site: Route / Loads / Method  
Building Load Bearing  
Max Size / Weight per Piece for Access  
Dry Storage before Erection  
Bases: Level / Load Brg / Releveling  
Dev's  
Bolting Adjacent Sections Onsite  
I.E. Heating & Cooling Coils  
Access / Maintenance / Withdrawal Plant  
Sun / Wind / Rain / Snow  
Saline / Icing  
Dust / Powder / Grit / Soot / Smoke / Sand  
Tall Units on Plinths Side Walkway?  
Are Top Access Door Catches In Reach?  
Containment & Drainage of Leaks Sloping,  
Differential Trapped  
Condense Drains, To Open Tundish  
Miswiring Motors Competent Electrician

## Delivery

---

## Receipt & Unpacking

Units are designed and manufactured according to ISO 9001

As part of our quality control system each unit undergoes a full pre-delivery inspection before loading. Units are then shrink wrapped to prevent ingress of foreign bodies or water during transportation.

All units are fitted with a full perimeter bases to facilitate lifting, moving and installation.



Unit wrapped ready for dispatch

Units should be inspected and any external damage or short delivery reported to ECE, **before unloading**.

We cannot accept responsibility for damage sustained during unloading from the delivery vehicle or on site.

Units must be off loaded, lifted and lowered using long lifting straps and timber blocks or using an “H” Frame with short lifting straps and timber blocks or a fork lift with extended forks.

Final lowering and side shifting to bring parallel faces together should be by toe jacks with timber blocks.

Internal joining bolts should never to be used to pull modules together.

Modules should never be rolled over to move across site.

Guidance notes for unloading and handling are given in the following pages.

Before commissioning all packaging materials must be removed from the units and cleared from the area.

## Fan Transport inspection

Check the fan immediately after you receive it and make sure that it has not been damaged during transport. If you discover any damage, get in touch with the ECE aftersales without delay. Briefly rotate the fan impeller to see that it rotates easily. Check the information on the fan rating plate.

Faulty conditions in transporting may result in serious damage on the product.

## Fan Intermediate storage

If the fan is to be switched off in between uses, the following needs to be taken in to account:

- The storage environment must be dry, dust-free and not have a high level of humidity (<70%)
- Storage temperature must be in between -25°C and + 40°C

---

## Copra Transport

### Transport Damage

Deliveries are to be immediately checked in the presence of the carrier as being intact and complete.

**NOTICE** *Transport fans carefully.*

Improper transport (for example setting the fan down roughly or at an angle) can lead to the following:

- Fan impellers getting jammed.
- Shafts getting deformed.
- Bearings getting damaged.
- Frequency converters getting damaged. The devices are packaged and secured in a box on a pallet in the factory.

### Transport Safety

- The transport medium should be selected according to the weight and packaging of the fan (type plate, datasheet).
- Always secure the load in accordance with applicable regulations.
- Use appropriate lifting points based on the installation situation and the centre of gravity position.

**⚠ DANGER** *Never spend time below suspended loads, as there is a risk of injury from components falling down.*

### Copra Attachment Points

#### COPRA Plug Series



Supporting structure



Supporting structure



Fitting lifting lugs in the positions provided

#### COPRA Core Series

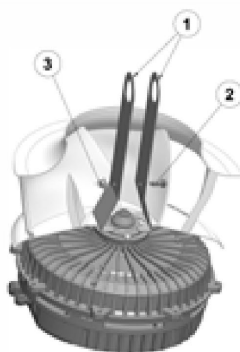

1. Lifting aid – 2. Locking screw – 3. Lock nut

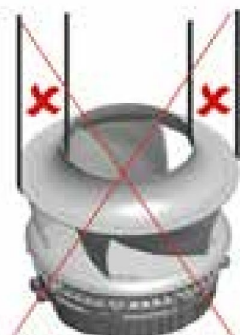
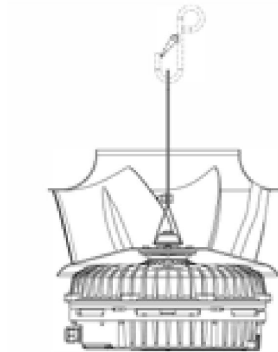

**NOTICE**

*Use the lifting aid available in the accessories to unpack the COPRA Core component.*

**NOTICE**

*No attachment points are: nozzle, impeller, motor, electronics.*

## Copra Temporary Storage

When storing the fan temporarily, always observe the following points:

- Store the fan in its packaging, adding any other protection dictated by its storage environment.
- The storage location must be dry and free of dust. The relative humidity must be < 70%, non-condensing.
- Maximum permitted storage temperature: -40°C to +85 °C.
- The impellers must be periodically rotated several times (at least every 3 months) and this must also be documented.



---

### Lifting

Crane - Long lifting straps (150mm min. width)

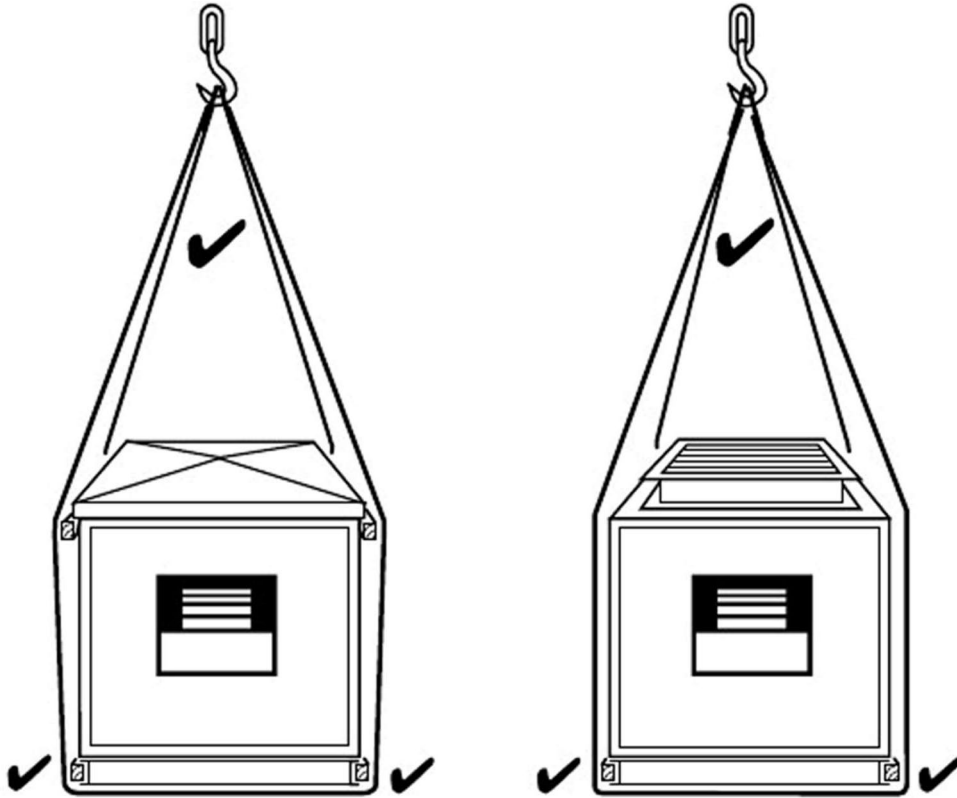

Crane – “H Frame” Short lifting straps (150mm min. width)

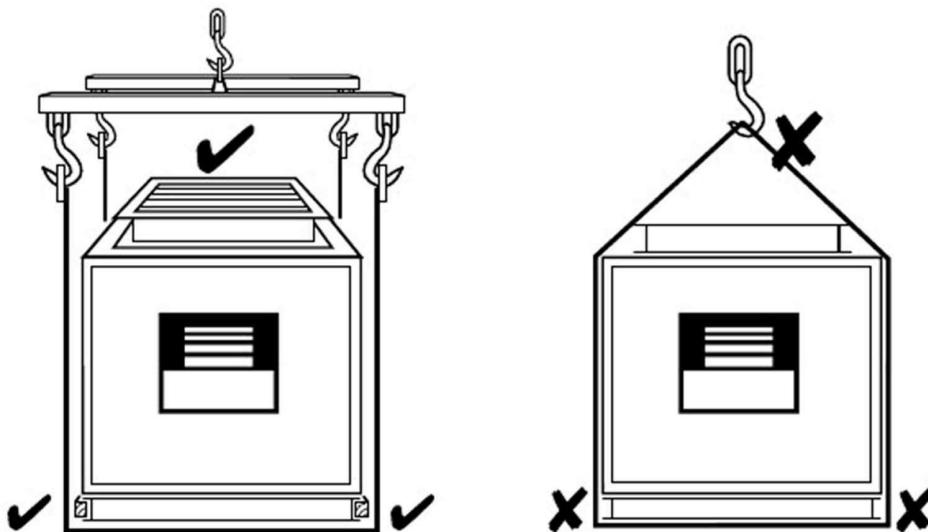

Lifting – With Base Frame Lifting Holes  
Crane - Long lifting straps (150mm min. width)

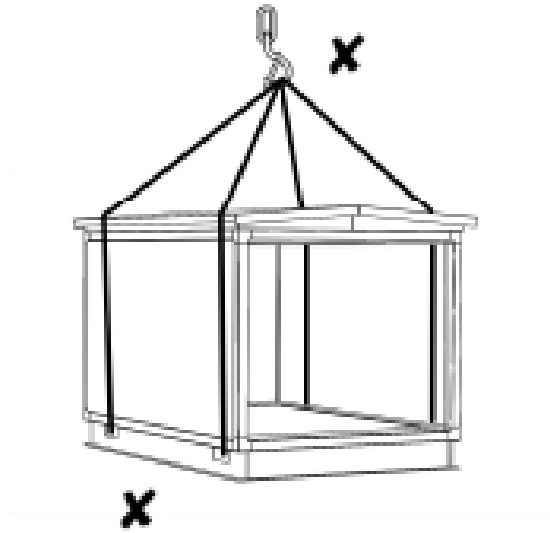
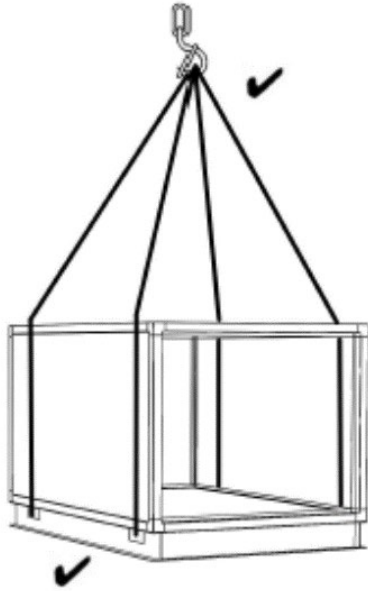

Crane – “H Frame” Short lifting straps (150mm min. width)

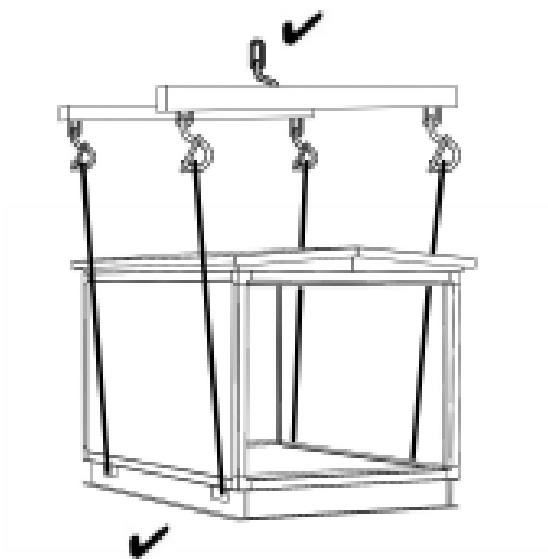

## Forklift

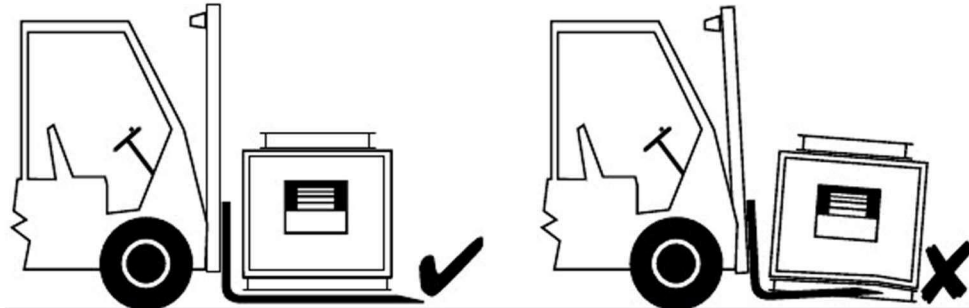

## Rollers

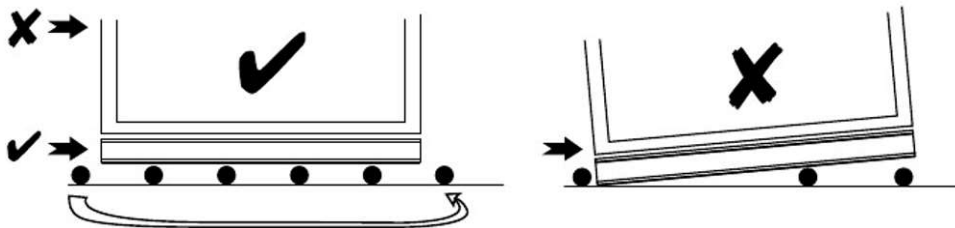

## Skates

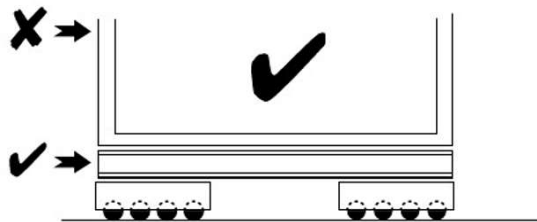

Toe Jacks

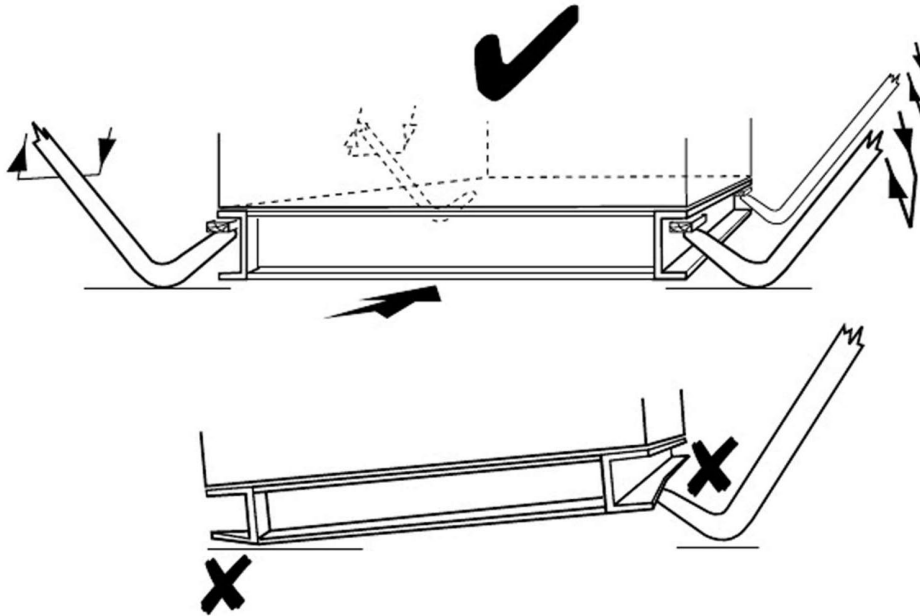

## Installation

---

## General

Electrical wiring and controls, water, steam, gas and refrigerant piping, line fittings and controls should be installed in accordance with appropriate governing institute standard practice (I.E.T. C.I.B.S.E. etc.) and together with the electricity supply, water supply and drains should conform to the appropriate authority and all statutory regulations.

Units with drains should be mounted at a level which allows installation of cleanable drain taps at each connecting point then installation of drain pipe work falling to an open tundish.

Space should exist for the application of sealant - jointing rubbers. Tightening of internal fixings. Internal installation, attachment or insertion of isolating, indicating, recoding, modulating, activating, devices, also making and tightening of fixings at connections to air Inlet and discharge ducts.

## Hinged Handle Access

When working internal to the AHU you must remove the access doors completely to stop personnel getting locked inside.

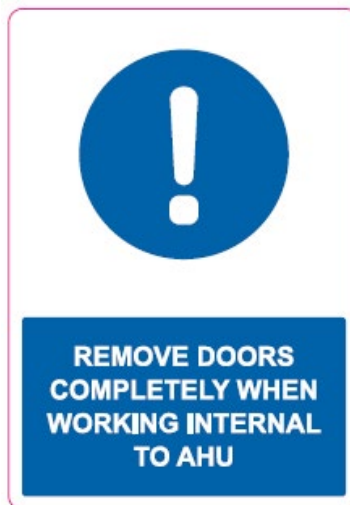

## Compression Latch-Hinge

### Product Details

- When the door is closed, the latch is adjustable (3mm) to achieve perfect alignment
- Compression (5 mm) with low opening & closing force
- Door or panel can be removed by unlatching the handles on both sides
- Right or left hinged
- Hinge 180° opening angle
- Available with or without pressure relief

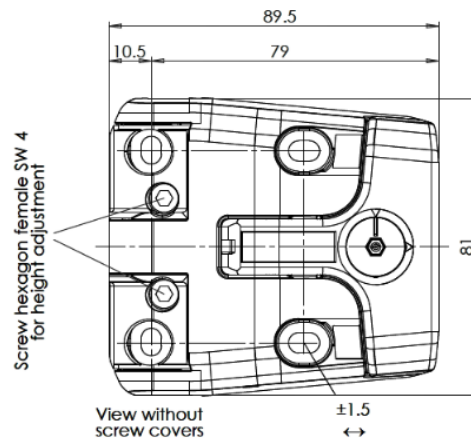
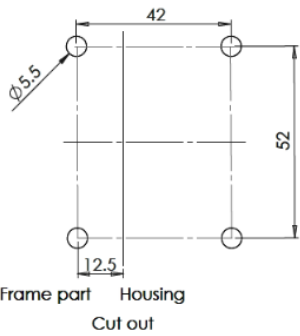
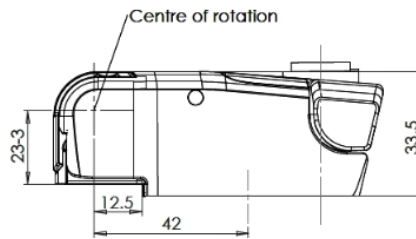
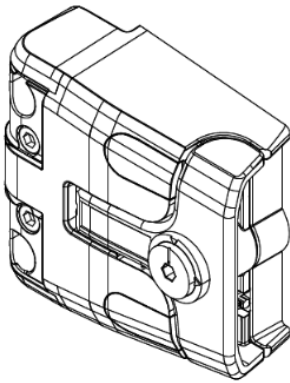

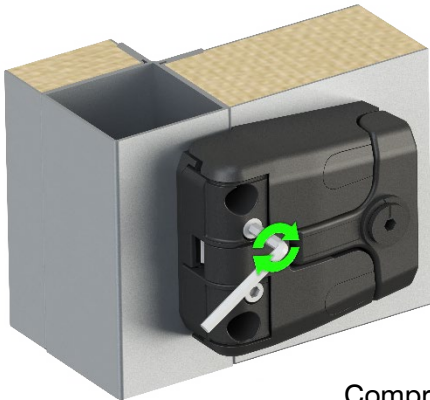

Compression  
Latch-Hinge locked

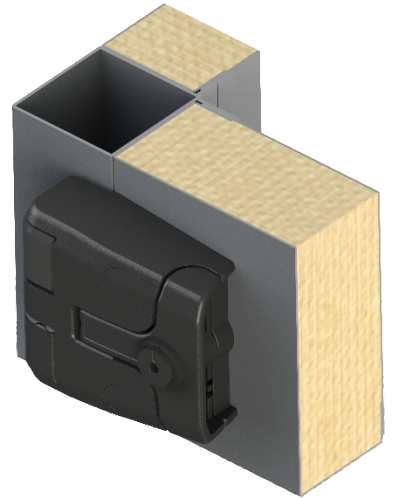

Compression adjustable  
on the frame part

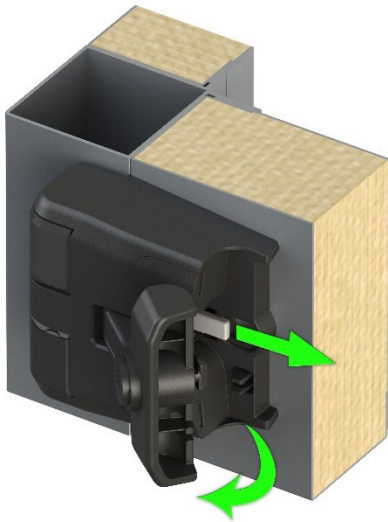

Latch-Hinge with pressure  
relief, handle unlocked

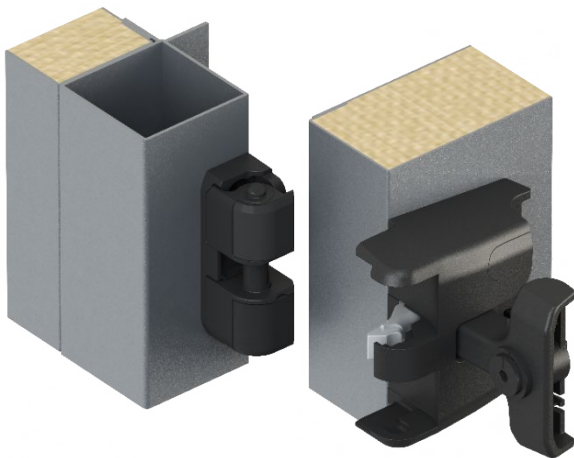
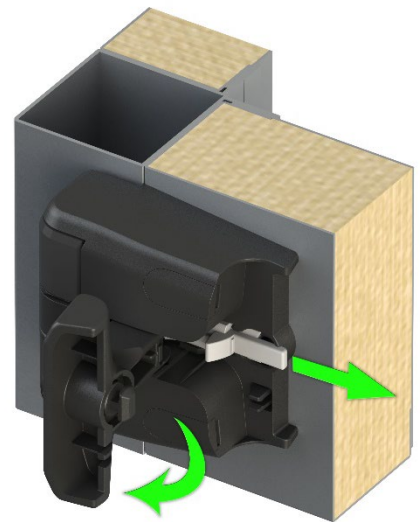

Latch-Hinge open

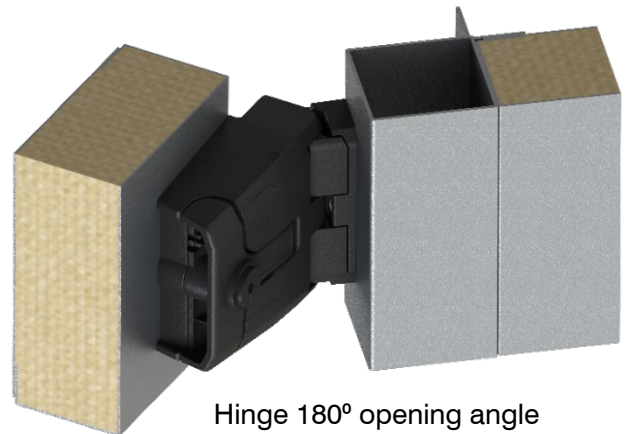

Hinge 180° opening angle



## Bases and foundations

All units must be installed on a permanent base which must be firm, level and structurally rigid. Units may be mounted on suitable steels or purpose build C.I. frames supported from the main roof structure providing this is capable of support the weight – see Check at Design Stage.

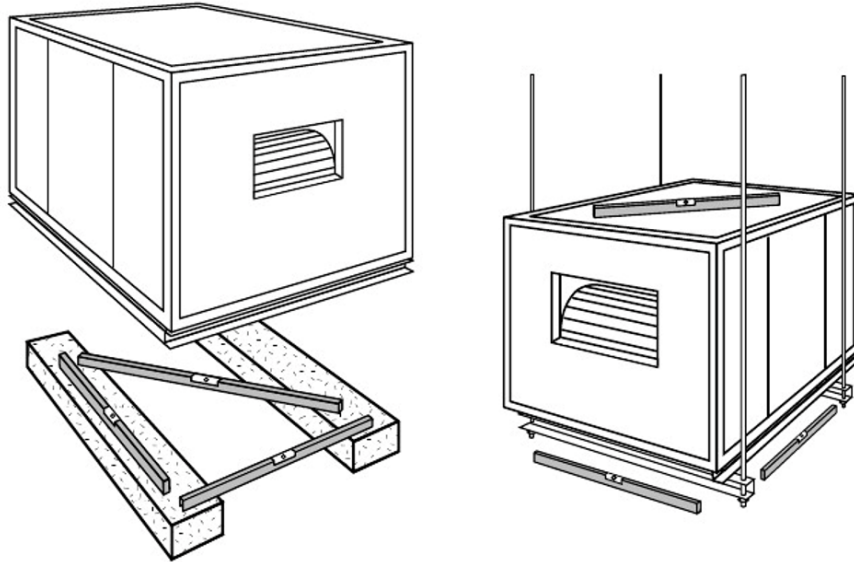

*“The use of Tico material to dampen vibration / noise is not recommended as it will cause uneven deflection due to variations in point loading within units. This will cause vertical joints to go “out of parallel” causing leakage at joints”*

When foundations are uneven units will “lozenge” if the installer attempts to use the joining bolts to pull non parallel faces together causing air leakage at joins, access doors will jam and not close after opening and duct connections will not be “parallel” and will leak.

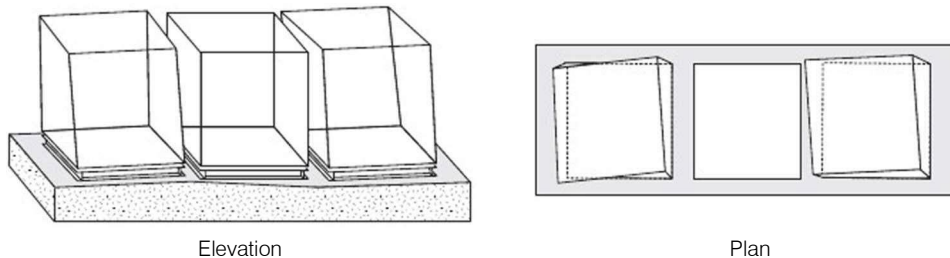

When foundations are level and perfectly flat units will be perfect cubes and will fit together squarely with good air seals, access doors will open and close correctly and duct connection are airtight.

Do not use joining bolts to pull units together in elevation or in plan.

Level Base – units perfect cubes

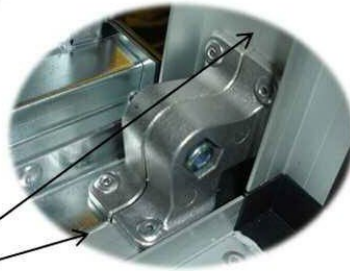
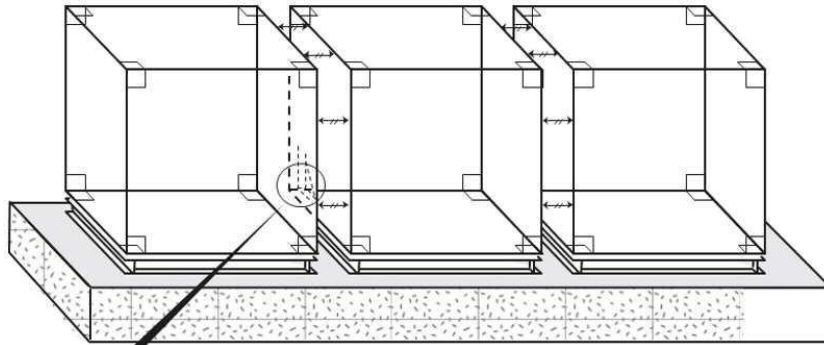

Thin mastic seal

## Plug Fans

The fan is secured to a base by bolts in mounting holes across anti-vibration mountings. The base must be level and stable. The fan must only be mounted in a horizontal plane. Either the fan or the base is mounted on anti-vibration mountings.



## Fitting the Accessories

The fan should normally be connected to the air handling unit by means of flexible connection or other type of gasket to eliminate vibration transfer from fan to AHU casing. Providing necessary grounding for the accessories is within the constructor's field of responsibility. Inlet protective screen can be fitted directly to the front frame or outside AHU to the inlet opening.

## Electrical Connections

All electrical connections must be wired by authorised personnel only. The necessary electrical and safety precautions must be taken into account. If the motor is operated across a frequency converter, the connections must be made according to the instructions of the frequency converter manufacturer. The motor must be grounded.

---

## Electric Heater Battery Controller Specifications

### *Model 2: Single Phase Thyristor Temperature Controller*

- 1 Phase from 0.75Kw to 4.5Kw
- Max. 4.5Kw @ 230v, maximum current 19.5amps.
- 0-10volt signal for set point temperature.
- Open or closed loop option BMS.
- On/Off volt free.
- Air Flow Switch 604X, volt free contacts, range 20 – 300pa fitted as standard.
- Over-Heat Cut-out OHC5, volt free contacts, max capacity 16amps
- Supply Fan 1, maximum 650w @ 230v Fan terminals are temperature-controlled
- Supply Fan 2, maximum 650w @ 230v.Constant run
- Duct Sensor, Thermistor Curve K 4.7K  $\Omega$  resistance @ 25°C
- 2 digit 0.56" 7 segment LED Display
- Push buttons (PCB mounted) up/down
- Power on – green. Flashing on standby. Solid is switched on.
- Heater on – amber. LED will pulse with demand and stay on with full load.
- Heater should not run 100% all the time.
- Error – red. Air flow fail, overheat trip, current fail, duct sensor fault.

Optional remote fault relay signal and air flow sensor, plugin board. This will replace the Air Flow Switch 604X and this can be done in our factory if requested. The part does add cost to the heater. (for very low air volume)

Optional remote fault relay signal board plugs into any heater.

The controllers meet the current EMC. EN61326-, EN55011, EN61000

*Model 4: Single Phase Thyristor Temperature Controller*

- 1 Phase from 5.0Kw to 8.0Kw
- Max 9Kw (2x4.5Kw) @ 230v, maximum current 39amps
- 0-10volt signal for set point temperature.
- Open or closed loop option.
- On/Off
- Air Flow Switch 604X, volt free contacts, range 20 – 300pa fitted as standard
- Ove- Heat Cut-out OHC5, volt free contacts, max capacity 16amps
- Supply Fan1, maximum 650w @ 230v Fan terminals are temperature-controlled
- Supply Fan2, maximum 650w @ 230v. Constant run
- Duct Sensor, Thermistor Curve K 4.7K  $\Omega$  resistance @ 25°C
- 2 digit 0.56" 7 segment LED Display.
- Push buttons (PCB mounted) up/down.
- Power on – green Flashing on standby. Solid is switched on.
- Heater on – amber LED will pulse with demand and stay on with full load.
- Heater should not run 100% all the time.
- Error – red- Air flow fail, overheat trip, current fail, duct sensor fault.

Optional remote fault relay signal and air flow sensor, plugin board. This will replace the Air Flow Switch 604X and this can be done in our factory if requested. The part does add cost to the heater. (for very low air volume)

Optional remote fault relay signal board plugs into any heater.

The controllers meet the current EMC. EN61326-, EN55011, EN61000

*Model 6: 3 phase Thyristor Temperature Controller*

- 3 Phase from 3.0Kw to 24.0Kw
- Supplied with SSR max 24Kw, maximum current 34.7amps per phase @ 400v
- 0-10volt signal for set point temperature.
- Open or closed loop option BMS.
- On/Off
- Air Flow Switch 604X, volt free contacts, range 20 – 300pa fitted as standard
- Over-Heat Cut-out OHC5, volt free contacts, max capacity 16amps
- Supply Fan1, maximum 650w @ 230v Fan terminals are temperature-controlled
- Supply Fan2, maximum 650w @ 230v. Constant run
- Duct Sensor, Thermistor Curve K 4.7K  $\Omega$  resistance @ 25°C
- 2 digit 0.56" 7 segment LED Display
- Push buttons (PCB mounted) up/down
- Power on – green Flashing on standby. Solid is switched on.
- Heater on – amber LED will pulse with demand and stay on with full load.
- Heater should not run 100% all the time.
- Error – red. Air flow fail, overheat trip, duct sensor fault.
- 

Optional remote fault relay signal and air flow sensor, plugin board. This will replace the Air Flow Switch 604X and this can be done in our factory if requested. The part does add cost to the heater. (for very low air volume)

Optional remote fault relay signal board plugs into any heater.

The controllers meet the current EMC. EN61326-, EN55011, EN61000

An additional module can be supplied to control 3 phase fans.

*Model 8: 3 phase Thyristor Temperature Controller*

- 3 Phase from 27.0Kw to 135.0Kw
- Supplied with SSR max 135Kw, maximum current 187amps per phase @ 400v
- 0-10volt signal for set point temperature.
- Open or closed loop option BMS
- On/Off
- Air Flow Switch 604X, volt free contacts, range 20 – 300pa fitted as standard.
- Over-Heat Cut-out OHC5, volt free contacts, max capacity 16amps
- Supply Fan1, maximum 650w @ 230v Fan terminals are temperature-controlled
- Supply Fan2, maximum 650w @ 230v. Constant run.
- Duct Sensor, Thermistor Curve K 4.7K  $\Omega$  resistance @ 25°C
- 2 digit 0.56" 7 segment LED Display
- Push buttons (PCB mounted) up/down.
- Power on – green Flashing on standby. Solid is switched on.
- Heater on – amber LED will pulse with demand and stay on with full load.
- Heater should not run 100% all the time.
- Error – red. Air flow fail, overheat trip, duct sensor fault.

Optional remote fault relay signal and air flow sensor, plugin board. This will replace the Air Flow Switch 604X and this can be done in our factory if requested. The part does add cost to the heater. (for very low air volume)

Optional remote fault relay signal board plugs into any heater.

The controllers meet the current EMC. EN61326-, EN55011, EN61000

An additional module can be supplied to control 3 phase fans.

---

## Installation

All heaters must be wired according to current IEE regulations and carried out by a competent person.

The controller has two options on the fan terminal Fan 1/2: Constant run and temperature controlled. By pressing the UP button, then the DOWN button for 5 seconds you can switch between the two by pressing up or down again F1 or F2 will appear on the LED display. If you are using for temperature controlled then F1, if for ventilation F2. Both will have fan run on. Once you have set it, restart system.

All units are labelled and recommends the customer takes note of the recommended airflow direction, as this should pass over the elements then over the manual overheat cut out. (OHC5). Also on the label is the power rating, wired for either 1 or 3 phase supply and how many element steps.

The 3-phase controller will require a neutral supply even though the elements will have a star point.

All units with controls will come with terminals for the customer to wire to.

Our 3 phase heaters without controls will be star point and no neutral connection is needed. Customers may only connect a neutral to the bus bar for test purposes. ECE can supply a neutral connection for this purpose if the customer so wishes. Over heat cut-out is 16amps 400v 125°C Max

If the customer needs to drill a hole in the unit, they should remove controller to be able to see and to avoid cutting through wiring.

As the nature of the controller is not waterproof, they must not be installed where it will get wet or be splashed by water.

The airflow pressure switch (604X) will perform better when fitted vertically, if the customer needs to fit the heater in a horizontal position it is advisable to refit the switch on the wider side plate of heater avoiding any internal wiring when screwing the switch into place.

The airflow hose kit which comes with the unit this will need one hose to be put on the + side of the airflow switch, if pushing air, then run up stream of the heater. Fit the hose to the – side of the air flow switch if pulling the air over the heater. You can fit to + and – side of the fan on low air flow situations Try to avoid placing the plastic hose too close to heater, but as it is up stream this is not usually a problem.



---

## Troubleshooting

In the event of controller not working, check power is on from the local isolator.

The controller comes with a link wire in the run terminals this must stay unless the customer wants to use an on/off switch or time clock from here. See our website for the many different ways the controller can be used.

Note: Unless isolated, the unit will remain LIVE even when using an on/off switch, this will be indicated by the green LED flashing to show mains power is on but the unit is not running.

Once the unit starts to run by timeclock, switch or if the link is left in, the Green LED will stay on continually.

The Red LED will light in the event of an error and the error code will be displayed on the digital display.

A flashing Red LED indicates that the fan 'run on' timer is operating.

The customer should always allow the fan to 'run on' to dissipate the radiant heat before turning off at isolator.

The controller can display the following error codes. Once an error has occurred the system will need to be turned OFF then ON again at the main isolator. Only E4 will not need resetting. If airflow restarts the heater will come back ON. We highly recommend fan run on (high power heaters), then no E4 error will appear.

E1... Heater 1 failed (2 and 4 models only)

E2... Heater 2 failed (4 has two stages but only requires one customer supply)

E3... Over heat trip (OHC5)

E4... Airflow fault (604X) See website under wiring and spec for low flow sensor AFSFRBMS

E5... Duct sensor fault (DS1)

The Heater with controller is supplied pre-wired and set, if for any reason the unit has been wired different from how ECE supplied the unit, an error code may appear if it has been wired incorrectly.

The 6 controller is a 3-phase model and will not show error codes E1 or E2 as it controls a Solid-State Relay and this cannot be monitored.

The duct sensor (DS1) will need to be installed between 1 and 2 meters down stream of heater, this will depend on the size and air volume. (The larger the heater the further you can move the sensor downstream). The installer will need to drill a 16mm hole to suit the IP66 grommet.

Controllers are programmed to raise the duct temperature up to 60 Degrees when used with room sensor and will then find the room temperature. In tests we found this will warm the room quicker to a comfortable temperature.

The Yellow LED will stay on while on full load and will start to pulse as the controller reaches the room temperature required.

The controller will go into standby if the room temperature rises by 3 degrees more than the desired set point, switching back on once the temperature falls.

Wiring for heaters without controls. All heaters come c/w earth connection and overheat cut-out.

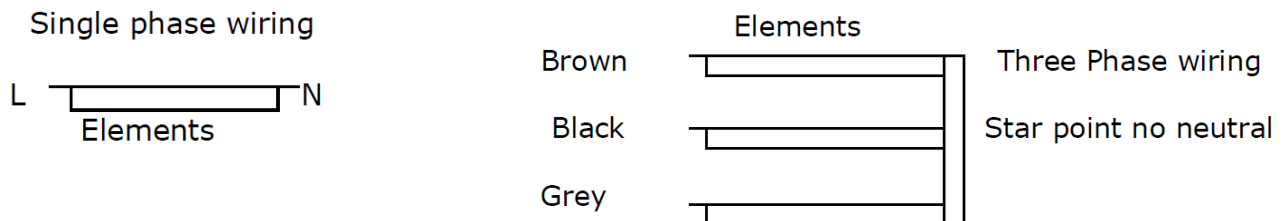

## BMS

*0-10-volt BMS instructions for operation and fan option set up*

To access the configuration menu, press and hold down the 'increment' button then press and hold down the 'decrement' button. After 5 seconds the display will change to show the first configuration option.

### **Configuration option 1, fan control:**

- Select F1 for the fan to operate only when the heater is on.
- Select F2 for the fan to run all the while the 'run' signal is on. (Default).

When no buttons are pressed for 10 seconds the display will move on automatically to the next option.

### **Configuration option 2, BMS Maximum Set-point:**

BMS Maximum Set-point = 0: Selecting zero for the maximum set-point disables the 0-10v BMS input signal.

The heater set-point will be taken from the manual display using the 'increment' and 'decrement buttons. (Default).

BMS Maximum Set-point any other value: The value entered becomes the heater set-point corresponding to an input signal of 10v on the 0-10v BMS input signal. For example, if 40 were entered as the BMS maximum set-point then the heater set-point would be 40°C when the 0-10v input was 10v. If the 0-10v input dropped to 5v then the heater set-point would be 20°C. The current heater set-point will be shown on the LED display. The 'increment' and 'decrement' buttons will have no effect on the heater set-point.

When no buttons are pressed for 10 seconds the display will return automatically to the normal operating screen.

## BMS Open or Closed Loop

To set up control 'BMS open loop' or 'closed loop BMS'

To do this

1. Press and hold '+' then press and hold '-'.
2. After 5 seconds the display changes to show the fan option; release '+' and '-':
  - a. F1: Fan on with the heater, or
  - b. F2: Fan on with the run signal. (default)
3. You can change the fan option using '+' and '-'
4. If no buttons are pressed for 10 seconds the display changes to show the control mode:
  - a. c1: local operation, (default)
  - b. c2: BMS closed loop, or
  - c. c3: BMS open loop.
  - d. c4: Set up for TRC-2 room controller
5. You can change the control mode using '+' and '-'
6. If no buttons are pressed for 10 seconds the display changes. The next screen depends on the control mode:
  - a. In mode c2:
    - i. The display now shows the BMS maximum set-point (i.e. the temperature set-point when the BMS input is 10v)
    - ii. You can change the BMS maximum set-point using '+' and '-'
    - iii. If no buttons are pressed for 10 seconds the display goes back to normal.
  - b. In modes c1 and c2 the display goes straight back to normal.

Here is a summary of the three control modes:

Mode	Title	Temperature Set-point	Output Power	Display Shows
C1	Local Operation	Set on the controller using the display and buttons.	Calculated by the controller from the set-point and duct/room temperatures.	Set-point (as selected using '+' and '-')
C2	BMS Closed Loop	Specified by the BMS using the 0-10v input. 0v means a set-point of 0°C 10v means a set-point of 'BMS maximum' (see step 6.a above).	Calculated by the controller from the set-point and duct/room temperatures.	Set-point (derived from the 0-10v input and 'BMS maximum')
C3	BMS Open Loop	Not applicable.	Specified by the BMS 0-10v input. 0v means 0% output power 10v means 100% output power	Heater power (derived from the 0-10v input)

If the customer requested 'Open loop BMS' the heater batteries will not come with sensors.

Wiring Diagrams

Model 4

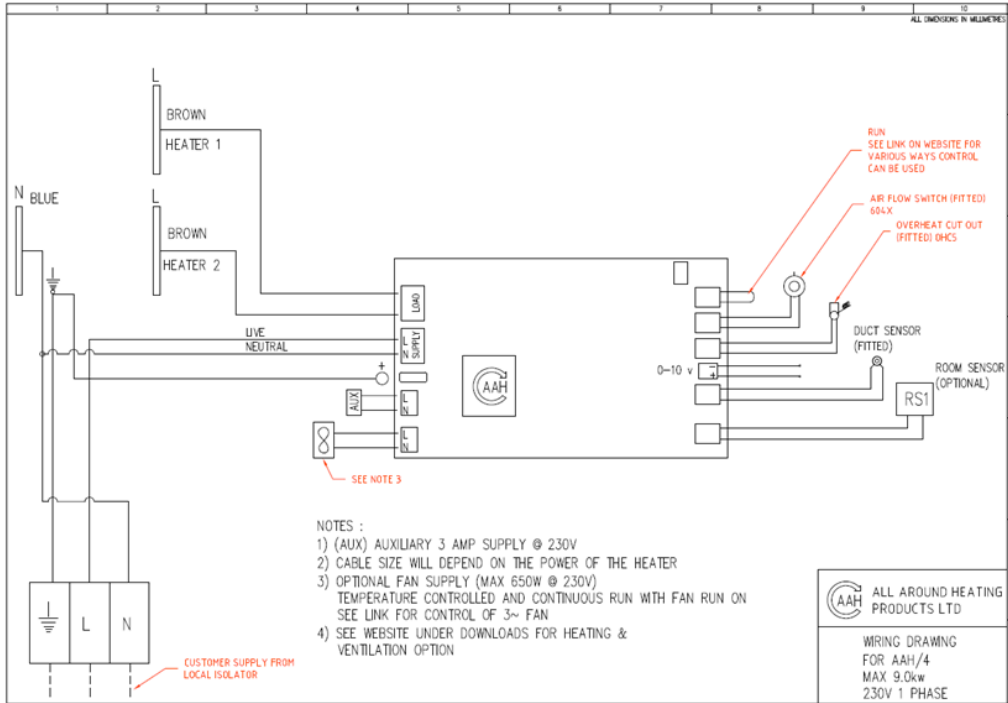

Model 6

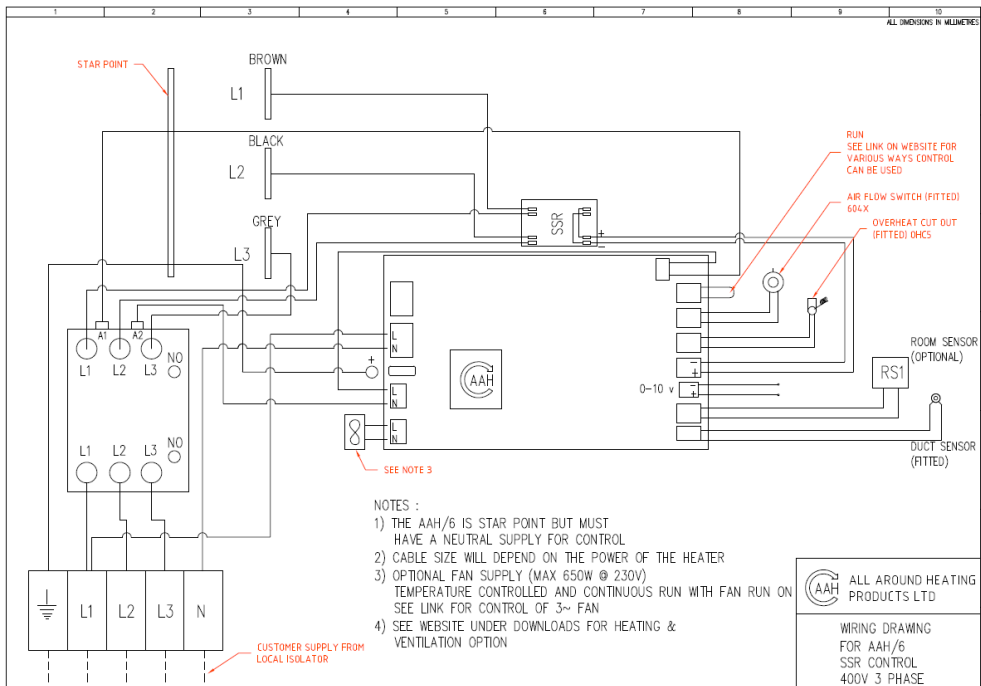

Model 8

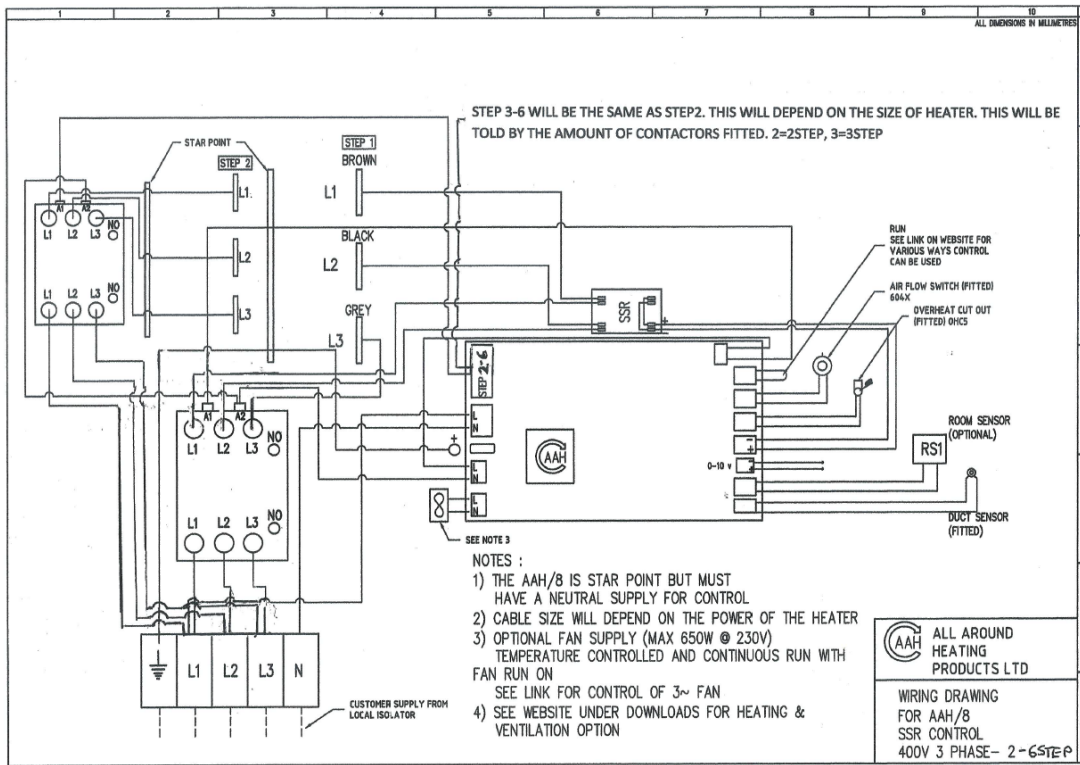

FRBMS

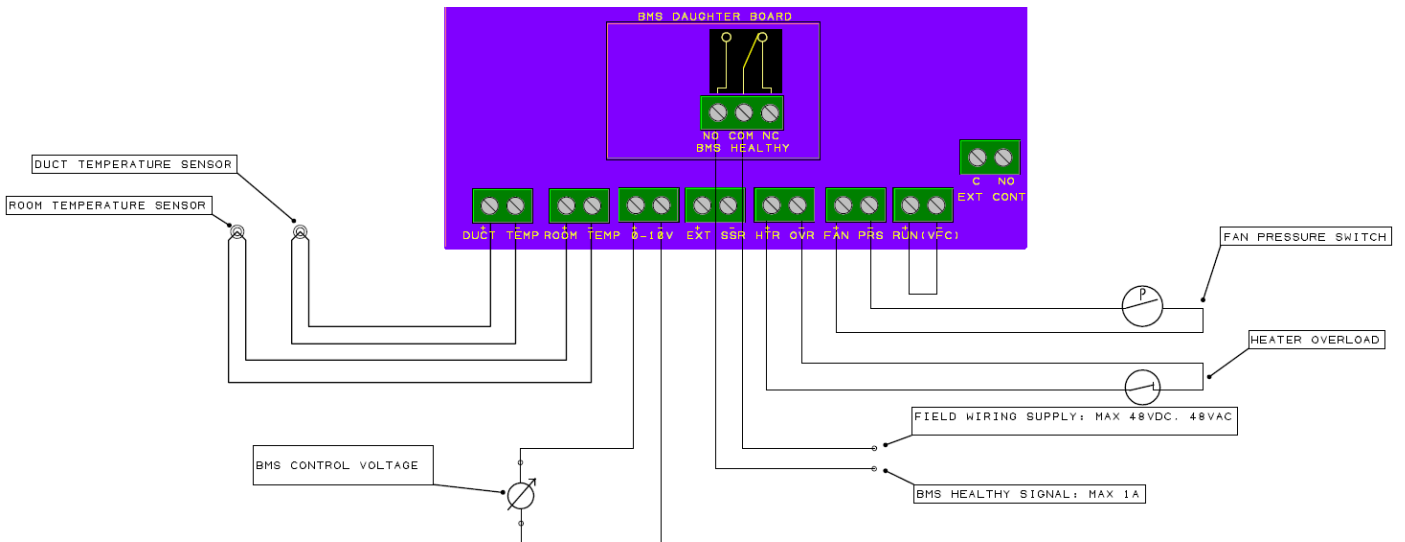

---

## Copra Installation

### Safety Instructions

#### **⚠ WARNING**

- The installation may only be carried out by specialist personnel, observing the information provided in the operating instructions and also applicable regulations.
- Any guards that were removed in order to perform installation work must be reattached immediately once this work has been completed (and before the electrical connection is re-established).
- The fans must be mounted in such a way that they are held securely in place at all times during operation.
- Attach the fans to the supporting structure (Plug) or the on-site motor installation plate (Core).

**⚠ CAUTION** *Shoring up the weight at other points leads to fan damage and is dangerous.*

### Installation Location

- The installation location must be appropriate and suitable for the respective fan in terms of its nature, condition, ambient temperature and ambient medium (also observe sections 3.3 and 3.4).
- The substructure must be flat and have the requisite load capacity.
- Include monitoring units if operational cannot be performed visibly.
- If condensation is likely to form, the fan may only be installed in the “shaft horizontal “ or “rotor at bottom” configurations. Ensure led draining of the condensation.

### Installation And Mounting

Attach the fan or base frame to the substructure without any tension or stress

**⚠ CAUTION** *Tension leads to fatigue fractures. These in turn adversely affect the function of the fan and can lead to personal injury and property damage.*

- No forces from system components may be transferred to the fan.

## Mounting Instruction

The COPRATM series fans have been designed for installation with horizontal or vertical shaft on a baffle. The baffle must be adequately dimensioned to handle the mass of the device without causing any vibrations. Please note that no assembly materials are included as standard. Nicotra Gebhardt recommends mounting the fan permanently to the baffle and sealing it. This can be performed on site using a sealing strip.

Type	Impeller ø	X
COPRA P/C-25	250	288
COPRA P/C-28	280	318
COPRA P/C-31	315	353
COPRA P/C-35	355	393
COPRA P/C-40	400	438
COPRA P/C-45	450	514
COPRA P/C-50	500	564
COPRA P/C-56	560	624
COPRA P/C-63	630	694
COPRA P/C-71	710	774

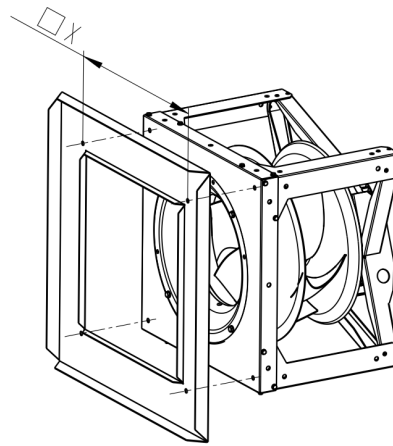

## Recommended Distances

As a distance to the chamber wall or to the nearest arranged fans in a fan grid, we recommend a ratio of 1.6 or higher to the nominal impeller diameter.

Size	COPRA Plug Height/Width (mm)	H1* (mm)
250	325	39.5
280	355	48.5
315	390	59
355	430	71
400	475	84.5
450	580	72
500	630	87
560	690	105
630	760	126.5
710	840	150.5

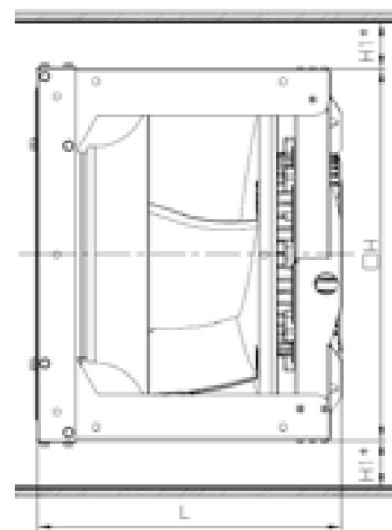

---

## Copra Electrical Connection

### Safety Instructions

#### **⚠ WARNING**

- The electrical installation of the fan and the components may only be performed by specialist personnel that have received corresponding training, observing the information provided in these Operating Instructions and applicable regulations.
- The following standards and directives must be observed here: IEC 60364-1 / DIN VDE 0100; DIN EN 60204-1. • Local regulations of the energy supply companies.
- As protection against unexpected start-up, fit devices in accordance with EN 60204--1 (for example lockable isolators).
- Always earth the fan properly.
- No potentially hazardous operating conditions may occur due to malfunctions of protective systems or their equipment.
- Protective systems should be provided on site. However, these are not included as standard by Nicotra Gebhardt.

#### **⚠ DANGER**

*There is electrical voltage in the intermediate circuit of the electronics and at the main connection when the permanent magnet motor is rotating.*

- Do not perform any work on the fan when the impeller/motor is rotating freely.
- Lock the impeller using suitable means

## EMC Compliant Installation

#### **NOTICE**

*Electromagnetic Compatibility directive according to 2014/30/EU is only applicable if the listed types and series are installed and commissioned in accordance with the operating instructions. If the listed types and series are integrated as system components into a system or operated with other components such as control or control devices, the operator or manufacturer of the entire system is responsible for compliance with the directive according to 2014/30/ EU.*

#### **NOTICE**

*According to EN 61000-3-2, these types/series are professional devices. Connection to the public low-voltage network is permitted as long as this has been coordinated with the respective energy supply company.*



## Mains Connection & Connection Plan

### NOTICE

*Establish the mains connection as per the information provided in these operating instructions.  
The COPRATM fans controller must be wired according to the locally adopted version of the NEC.  
A licensed, qualified electrician should complete the wiring for this product.*

The controller is designed to operate with 230/460 Vrms, three phase power. For the AC mains connector, the wire gauge should be no larger than 14 AWG for 1.3kW motors, and no larger than 12 AWG for 4.5kW and 8kW motors. The wire can be single or stranded. The wire insulation should be stripped to approximately 0.59-0.62". The connectors for analogue and digital I/O can accept bare wire between 16-24 AWG, with the insulation stripped to approximately 0.35" (min) Per datasheet 9mm = 0.35"

### Overview Supply Connections

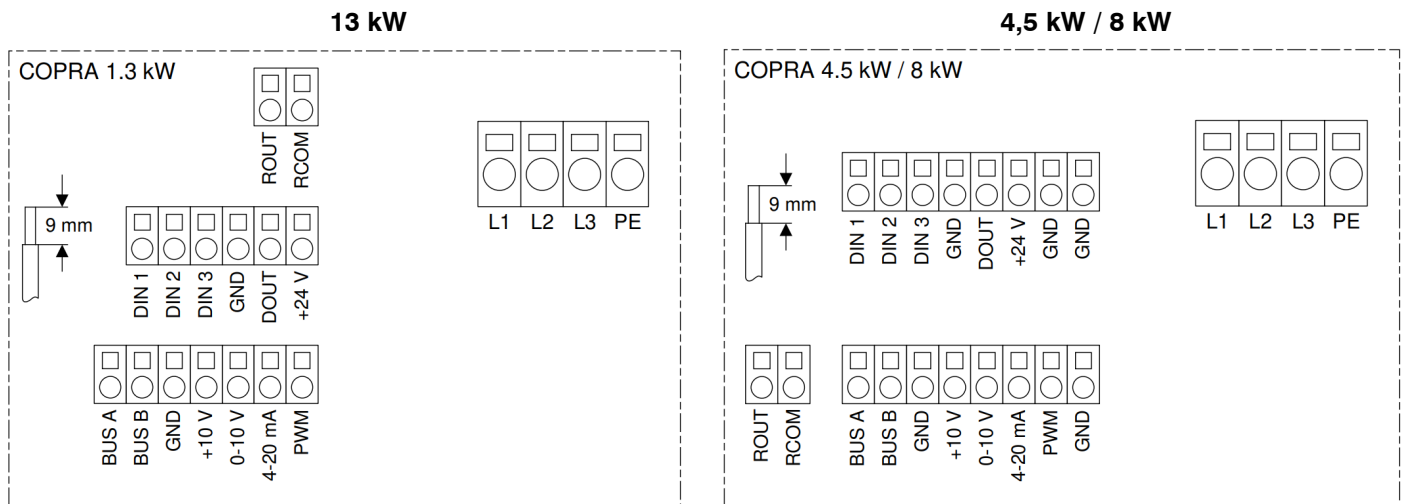

### Supply Connections

- L1: Connection terminal for phase 1
- L2: Connection terminal for phase 2
- L3: Connection terminal for phase 3
- PE: Connection terminal for protective conductor

### Control Connections

- DIN1: Digital input 1; Factory setting: Motor enable when at +10 to 24 Vdc
- DIN2: Digital input 2; Factory setting: Specification fixed speed
- DIN3: Digital input 3; Factory setting: Specification fixed speed

DIN3	DIN2	Speed
0	0	0
0	1	Speed1 (40%)
1	0	Speed2 (60%)
1	1	Speed3 (80%)

- Further common specifications of digital inputs DIN1, DIN2, DIN3: Input impedance of 67 kΩ, max. voltage: 24 Vdc, LOW/HIGH: 3.3 Vdc.
- GND: Reference potential (0 V) for digital and analogue control signals; all GND terminals are internally connected
- DOUT: Digital output; Factory setting: Display of actual speed by PWM signal (3.3 Vdc / 100 Hz)
- +24 V: 24 Vdc supply for external display/control/regulation devices; max. current: 100 mA
- BUS A, BUS B: RS485 interface for Modbus RTU connection
- +10 V: 10 Vdc supply for external potentiometer; max. current: 100mA
- 0-10 V: Analogue input for 0-10 V control signal; input impedance: 11 kΩ, max. voltage: 24 Vdc (0 -11.5 V readable)
- 4-20mA: Analogue input for 4-20 mA control signal; input impedance: 150 Ω, max. voltage: 24 Vdc, max. current 30 mA (0 -22 mA readable)
- PWM: Analogue input for pulse-width modulated voltage signal; voltage range: 10 - 24 V, frequency range: 50 - 1000 Hz, control range-duty cycle: 5 - 95 % (0 - 100 % readable)
- ROUT, RCOM: Potential-free relay contacts for indicating faults or operation; factory setting: indication of faults (wire-break-proof design; contact closes shortly after switching on the power supply and opens in case of fault or interruption of the power supply), max. switching voltage/current: 2A max/30Vdc or 2A max/30Vac, rated contact resistance: 100 mΩ

Maximum and minimum input values				
Input	Unit	Minimum	Nominal Value	Maximum Value
Mains voltage (230 V)	V	200 V	230 V	240 V
Mains voltage (460 V)	V	380 V	460 V	480 V

---

RLM Installation  
Electrical Connections  
Safety Notes

The electrical installation of the fans and components may only be carried out by trained personnel in observance of these Operating Instructions and the regulations in force.



The following Standards and guidelines are to be observed:

- IEC 60364-1 / DIN VDE 0100; DIN EN 60204-1
- site regulations of the Electricity Supply Companies
- Equipment in accordance with EN 60204-1 is to be installed as protection during unexpected events (e.g. an isolation switch for inspections).

Caution electrical hazard!



Electrical potential at intermediate circuit of Driver and power connections if the permanent magnet motor rotates!

- do not work at the fan if the impeller/motor is not locked
- lock fan impeller by proper means

---

## Connections to the grid

Connect the fan to the grid according to the enclosed connection diagram or the enclosed operating instructions (of the drive).

**CAUTION**

- PM motors without integrated electronics may only be connected to a frequency inverter suitable for that purpose.
- It is not permitted to operate more than one of the permanent magnet motors with one frequency inverter
- Only use screened motor cables.
- The motor cable screen must be attached to both sides

## Motor Protection

- Please check the maintenance instructions of the motor manufacturer
- Motors are to be protected against overload in accordance with EN 60204-1.
- Standard motor protection switches are to be provided and set to the nominal motor current. A higher setting is not permitted!
- Care must be taken to ensure for explosion protected motors that motor protection devices are utilised which correspond with the time given on the motor type plate.
- Motors with built-in thermistors or similar must be protected through a thermistor or similar operated release device.

**CAUTION**

Fuses or circuit breakers do not provide sufficient motor protection. Damage due to insufficient motor protection invalidates the manufacturer's guarantee.

## Motor Starting

Motors with a nominal rating of 4kW can generally be direct started.

Motors with a nominal rating >4kW are usually star-delta or soft started. For frequency inverter operation the start-up ramp must be selected so that the current rating of the motor is not exceeded.

In all cases the power limitations provided by the existing power supply company must be taken into account.

In the event that plant conditions necessitate a direct start the suitability of the fan design is to be confirmed with ECEUK Ltd. Fans with high inertia impellers can take over 6 seconds to reach top running speed. In these cases heavy duty motor protection relays or bimetal relays must be provided.

The motors are designed for S1 continual operation. With more than three starts per hour the suitability of the motor is to be confirmed by ECEUK Ltd.

**CAUTION**

PM motors without integrated electronics must be operated at inverters suitable for that purpose! (e.g. Danfoss VLT HVAC Drive FC-100)

## Supply and Extract Unit Fan Type & Speed Control

---

## Copra Information

### Important Information

The fans are state-of-the-art and fulfil the basic safety and health requirements of the EC Machinery Directive. The fans offer a high level of operating safety and a high standard of quality, which is guaranteed by a certified quality management system (EN ISO 9001). Before leaving the factory, all fans are checked and have a CE quality mark applied. Any fan can potentially present hazards:

- if it is not installed, operated and maintained by trained personnel.
- if it is not used for the intended use.

This can present hazards to the life and limbs of personnel, as well as material damage to systems and the building, while the benefits associated with the product can also be impaired.

**NOTICE** *All persons that are commissioned to work on the fan must both read and observe these Operating Instructions.*

## Operating Instructions

- describe the intended use of the fan and offer protection from improper use.
- include safety instructions that must always be observed.
- warn of hazards that can also potentially occur during the intended use.
- provide important notes on safe and efficient use of the fan, as well as helping to secure the full benefits associated with the product.
- are to be supplemented by specialist and country-specific standards/regulations and policies.

Nicotra Gebhardt GmbH accepts no liability for any damage or malfunctions that can be attributed to failure to observe the Operating Instructions.

The manufacturer warranty ceases to apply as soon as any unauthorised modifications or changes are made to the fan. No liability is accepted for consequential damage.

## Safety Instructions

**⚠ DANGER**

Indicates a hazard which, if not avoided, will result in serious injury or death.

**⚠ WARNING**

Indicates a hazard which, if not avoided, could result in serious injury or death.

**⚠ CAUTION**

Indicates a hazard which, if not avoided, could result in minor or moderate personal injury.

**NOTICE**

Indicates information considered important, but not hazard-related (e.g. messages relating to property damage).

## Copra Technical Description

**⚠ CAUTION**

*The fans are designed for installation in devices or systems and do not offer any dedicated touch protection as standard. Corresponding protective measures as per DIN EN ISO 13857 should therefore be implemented.*

The fans are driven by a permanent magnet synchronous motor (PM motor). The optimised radial impeller with backward curved, dust repellent hollow-profile aluminium blades is mounted directly to the motor shaft. This is statically and dynamically balanced as per DIN ISO 21940-11. Performance measurements in accuracy class 1 according to DIN 24166 on certified test benches according to ISO 5801. Noise measurements according to DIN 45635. The fans of the COPRA series have an integrated controller (EC/PM technology). Surface corrosion protection systems are available in both galvanized steel and powder coated steel and aluminium.

### COPRA Core

Motor impeller unit can be fitted in each installation orientation



### COPRA Plug

Fan module with support unit and inlet nozzle, installed and adjusted in the factory. COPRA can be fitted in each installation orientation.



## Specifications

Specifications and permitted limit values should be taken from the type plate, the technical datasheet, the tender information or the respective technical catalogue and always observed.

### Intended use

The fans are suitable for conveying dust-free air and other nonaggressive gases/vapours. They are designed as components for installation in devices or systems.

Permitted conveying medium temperature at a density of 1.2 kg/m <sup>3</sup> .	
Series	COPRA
Temperature	-20°C to +40°C

**NOTICE**

*Max. ambient temperature at the drive motor: +40°C. Any other use is considered improper use. No liability is assumed for personal injuries and/or damage to property resulting from this.*

The recommendations of the device manufacturer for preventing electromagnetic interference (EMI) are to be observed (earthing, cable lengths, cable screens, etc.).

---

## Improper use

The following are examples of improper use (conveying media):

- Media at impermissibly high or low temperatures
- Very wet media
- Aggressive (e.g. strongly acidic or alkaline) media with pH values < 5 or > 8 media
- Very dusty media
- Abrasive media
- Chlorinated media
- Explosive media

Unauthorized operating conditions:

- No operation above the indicated rotational speed (type plate, specifications).
- No operation in rotational speed ranges with increased vibration (resonance) after commissioning in the system.
- No operation in rotational speed ranges outside the permitted characteristic range (flow instability).
- No operation if the fan becomes heavily soiled or imbalanced.
- No operation if the fan has not been mounted in a way that prevents forces and stress from acting on it.
- No operation in potentially explosive atmospheres. This can lead to the following consequences: Motor damage, corrosion damage, imbalance, vibration, deformation, abrasion damage.

**⚠ WARNING**

*Avoid dynamic stress of the impeller, as well as frequent load cycles. The following can potentially occur here: Personal injuries and damage to property due to impeller breakages, shaft breakages, fatigue fractures, fire and explosions caused by sparking.*



## RLM Technical Information

### Product Description



The fans are intended for incorporation into equipment and do not have their own contact protection fitted as standard. The appropriate protective measures are to be taken in accordance with DIN EN ISO 13857

The centrifugal fans RLM/RLC, optimised for use without scroll. Direct drive with mounted standard motor construction B3/B5 or a permanent magnet excited synchronous motor (PM motor). The centrifugal impeller with backward-curved blades is attached directly to the motor shaft. Certain fans in the RLM/RLC range have an integrated frequency inverter.

**RLM E6 / G6 / E3 / 56 / 53 / 55**

Motor impeller with inlet cone (E3/53), motor block and base frame (E6/G6/55/56), installed and adjusted at the factory.

**RLC E6:** AMCA certified series, identical to RLM E6

RLM E3 / 53

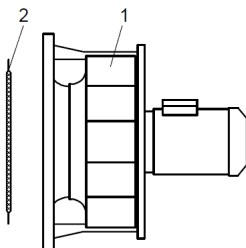

RLM 55

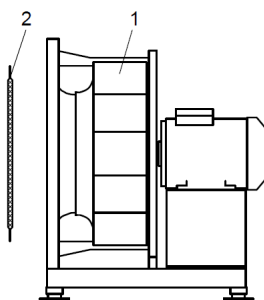

RLM E6 / G6 / 56 ; RLC E6

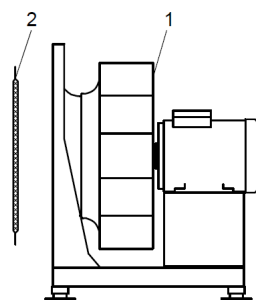

1. Fan
2. Inlet guard

## Technical Data

Technical data and the permissible limits are to be taken from the type plate, the technical datasheets or the appropriate technical catalogue and must be adhered to.

## Authorised use

The fans are intended for the transport of dust-free air and other non-aggressive gases or vapors.

Permissible media temperatures:

Range	RLM/RLC
Temperature	-20°C to +40°C

Maximum ambient temperature at the drive motor: +40°C.

### CAUTION

Ambient temperature with the Danfoss FCP-106 mounted frequency inverter: -10 °C to +40 °C  
Any installation deviating from the above shall be considered unauthorised.



ECEUK Ltd will not be responsible for any injury to personnel and/or material damage resulting from any deviations from the above!

Should any control equipment utilising electronic components be employed (e.g. frequency inverter), the recommendations of the manufacturer are to be observed concerning the avoidance of electromagnetic radiation (EMC) (through suitable earthing, cable lengths, cable screening, etc.).

## Improper Use

An improper installation would be e.g. the transporting of:

- media with unacceptable high or low temperatures
- aggressive media.
- very dusty media.

unauthorised operation

- No operation above the indicated rpm (see type plate, data sheet)!
- No operation at rpm ranges with increased vibration (resonance)!
- No operation at rpm ranges out of permitted fan curve area (instability of flow pattern)!
- No operation if fan becomes polluted!

The results are: Bearings damage, corrosion damage, loss of balance, vibration, deformation, abrasion damage.

### CAUTION

Prevent dynamic stress on the impeller, avoid frequent load changes!



Danger points:

There can be injury to personnel and material damage through impeller breakage, shaft breakage, fatigue failure, fire from spark creation.

---

## Important Information

These Fans are of state of the art design and comply with the requirements for health and safety of the EU Machinery Directive.

Nicotra Gebhardt Fans offer a high level of operational safety and a high standard of quality which is guaranteed through a certified Quality Assurance System (EN ISO 9001).

All fans leave the factory after being subjected to testing and are provided with a test seal.

All fans however can be dangerous,

- if they are not installed, operated and maintained by trained personnel
- if they are not used for approved applications.

This can endanger the life and limbs of personnel, provoke material damage to buildings and equipment and influence the use of the product.



Attention!

These Operating Instructions must be read and observed by all personnel engaged on works involving fans!

## Operating Instructions

- Describe the approved applications for the fans and protect against misuse.
- Contain safety notes which must be closely observed.
- Warn of dangers which can exist even with correct applications.
- Give important information on safety and the economic use of the fan while ensuring the full benefits of the product are available.
- Are to be complemented with the trade and national Standards, Regulations and Directives.

ECEUK Ltd accepts no responsibility for damage or breakdowns which can be traced back to non-observance of the Operating Instructions.

The manufacturer's guarantee does not apply following unauthorised and unacceptable conversions and alterations to the fan.

There is no responsibility accepted for resultant damages!

---

## Trend - VSD2H Variable Isolator Speed Drives

### VSD2H Variable Isolator Speed Description

Variable motor speed drives suitable for HVAC applications where the speed control of motors can be applied. They convert fixed frequency and voltage from the mains supply to variable frequency and voltage enabling motors to be used with maximum efficiency resulting in significant energy savings.

The control keypad can be mounted on the front of the unit or can be remotely connected by way of a 2 m cable and mounted on a panel or used as a handheld unit.

The keypad accesses the startup wizard which facilitates the application configuration for the user (pump/fan, PID loops, multi-pump, cascade control).

### VSD2H Variable Isolator Speed Features

- 380 to .480 Vac 3 phase
- Current rating range from 3 A to 310 A.
- IP21 and IP5.4 models available
- Optional Trend system network interfaces (NXNI or NXIP)
- Application configurable using wizard for a number pump or fan scenarios.
- Real time clock fitted with battery
- Integrated RFI filter for typical building installation
- Versatile PC tools available
- Slim, space-saving, "bookshell" design
- Varnished printed circuit boards to maximise reliability.

### Physical (dimensions in mm)

#### Physical (dimensions in mm)

3 A to 105 A units (unit size MR4 to MR7) - wall mounting

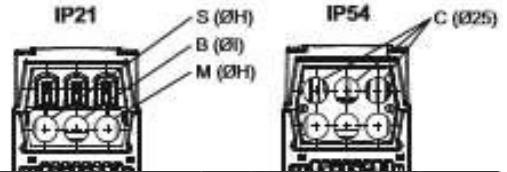
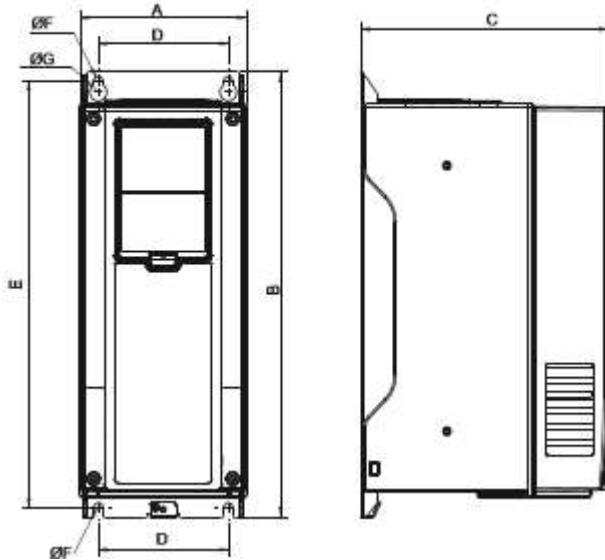

Current (A)	A	B	C	D	E	ØF	ØG	ØH	ØI	Frame
3 to 12	128	328	190	100	313	7	13	25	25	MR4
18 to 31	144	419	214	115	406	7	14	33	25	MR5
38 to 61	195	557	229	148	541	9	15.5	40	33	MR6
72 to 105	237	660	259	190	645	9	16	50	50	MR7
140 to 205	290	966	343	217	947	9	16	60	60	MR8*
261 to 310	480	1150	365	400	1122	9	16	59	59	MR9*

cal (continued)

(dimensions in mm)

140 A to 205 A units  
(unit size MR8)  
wall mounting

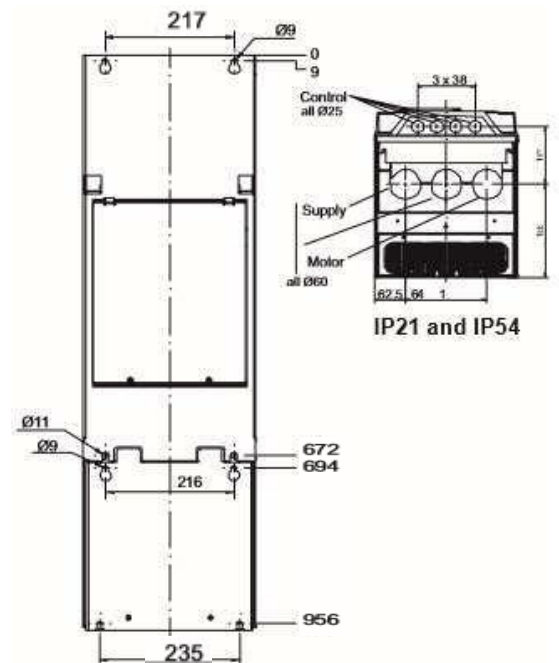
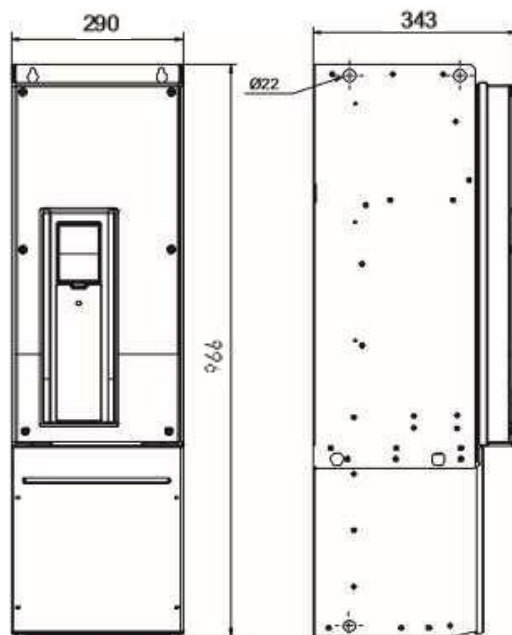

### 261 A and 310 A units (unit size MR9) wall mounting

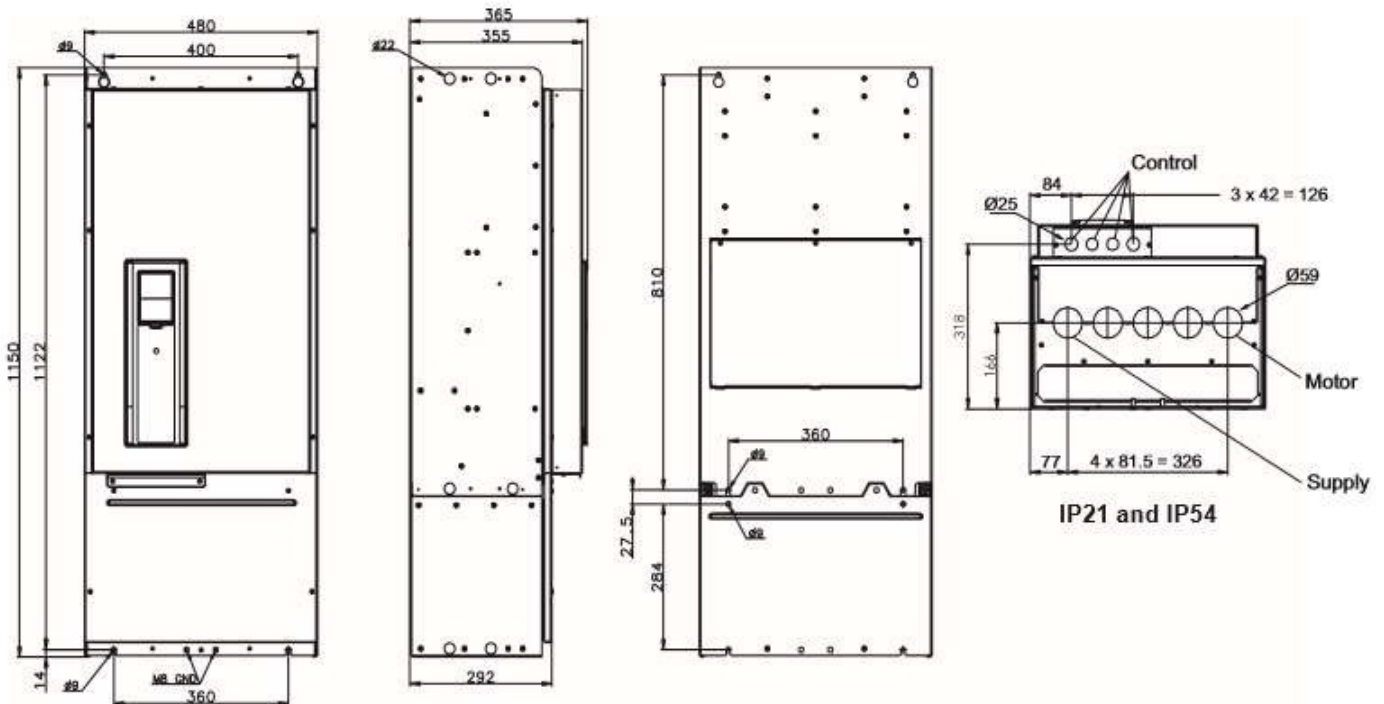

## Functionality

The VSD2H range of variable speed drives provides 20 models (3 A to 310 A) for voltages from 380 to .480 Vac 3 phase with either IP21 or IP5.4 rating. Designed for use in the HVAC environment they enable fans and motors to regulate delivery of air and water in variable flow applications. Where flow rates may be reduced, motor energy can be significantly cut as the relationship between flow rate and power follows a cube law hence reducing flow by 20% reduces power by 50%. The drives also enable saving in installation costs: switchgear is eliminated, motor cables are reduced from 6 to 3 wires for larger drives, power factor correction capacitors are not required, size and cost of cabling and fuses is minimised (as starting current is kept within nominal value).

The built-in application can be configured to suit the user's application using the start-up wizard; select either pump or fan, and enter nominal motor information. There are additional mini-wizards for setting up multi-pump control and the PID controller, and performing a resonance sweep.

### Hardware

- **Unit:** The unit is housed in a slim, space saving, bookshelf style enclosure that should be mounted vertically on a wall or on the back panel of a cubicle. Enough space should be left round the unit for cooling. Most units have .4 point mounting with two keyhole slots.
- **System:** The drive consists of the main unit, the cover, and a detachable keypad unit.

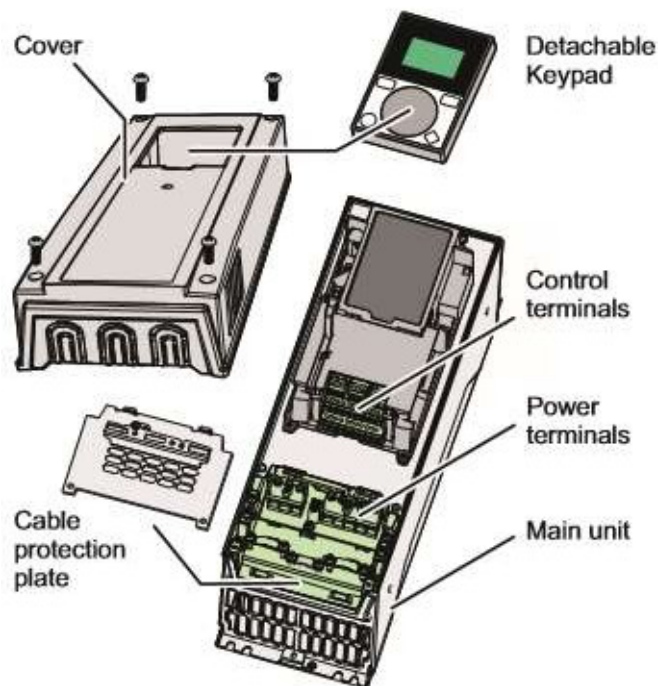

**Main unit:** The main unit consists of the power unit and the control unit.

The unit will be housed in a slim, space saving, bookshelf style enclosure that should be mounted vertically on a wall or on the back of a cubicle. Enough space should be left around the unit for cooling. Most units have .4 point mounting with two keyhole slots.

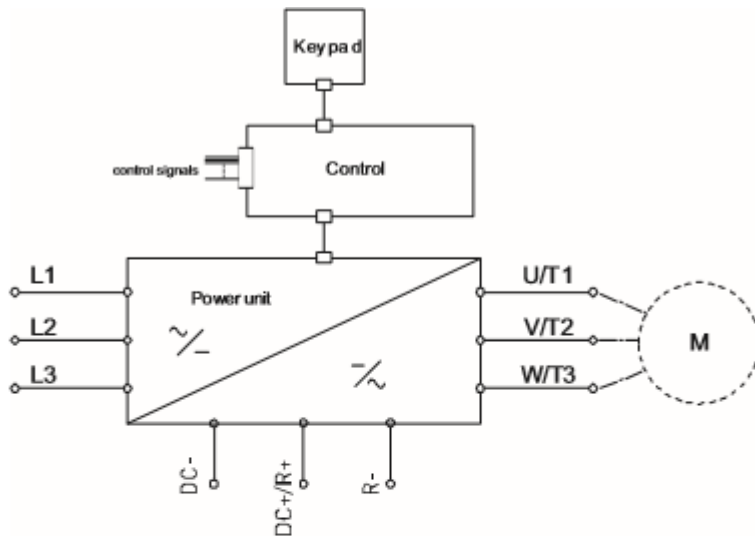

The power unit provides connections for the input mains supply (L1, L2, L3) and the output supply to the motor (U, V, W).

The control unit is based around a microprocessor. The microprocessor controls the motor based on the information it receives through measurements, parameter settings, control I/O and from the control keypad. The control unit of the frequency converter consists of the control board and up to 4 additional boards connected to the slot connectors (identified by letters A, B, D, E) of the control board.

The power unit provides connections for the input mains supply (L1, L2, L3) and the output supply to the motor (U,V,W).

The control unit is based around a microprocessor. The microprocessor controls the motor based on the information it receives through measurements, parameter settings, control I/O and from the keypad. The control unit of the frequency converter consists of the control board and up to .4 additional boards connected to the slot connectors (identified by letters A, B, D, E) of the control boar



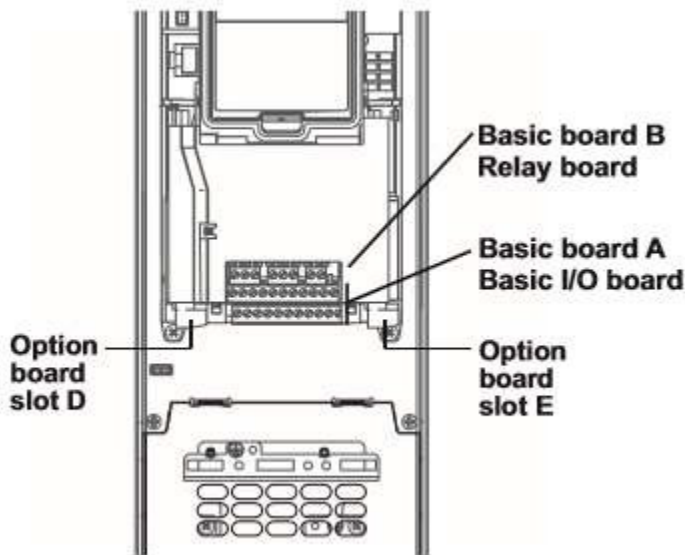

When the frequency converter is delivered from the factory, the control unit includes the standard complement of two basic boards, the basic I/O board in slot A, and the Relay Board in slot B.

Additional boards can be added to slots D and E. An NXIP or NXNI Trend network interface can only be fitted in slot D.

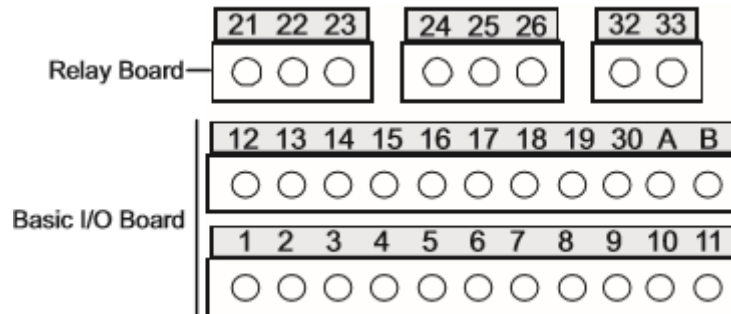

The basic boards terminals are shown above. The basic I/O Board (fitted as standard) has:

2 analogue input channels, separately switchable to voltage (0(2) to 10V) or current (0(.4) to 20 mA) 6 digital input channels (0 to 5 V =0, 15 to 30 V =1)

1 analogue output channel, switchable to voltage (0 to 10V) or current (.4 to 20 mA). RS.485 serial bus terminal pair (for BACnet MS/TP or Modbus)

The defaults for the analogue inputs and output are indicated in the diagram below; they may be changed using the DIP switches (see below).

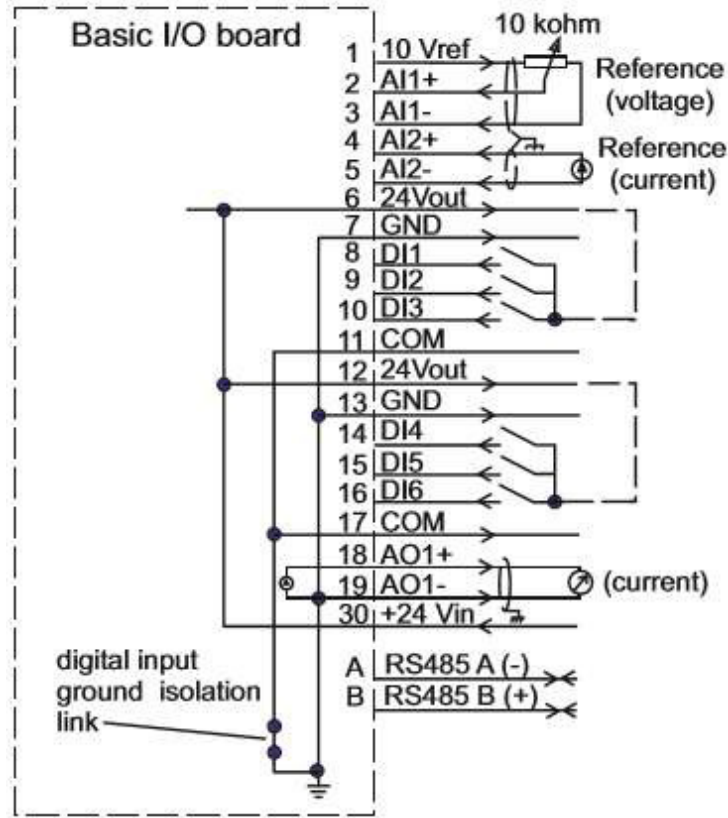

Terminal	Signal	Information	Factory Setting
1	10 Vref	+10 Vdc Reference voltage	10 mA max.
2	AI1+	Analogue input 1 voltage or current	DIP switch 4 selects V or mA. Differential input if not connected to ground
3	AI1-	Analogue input 1 common	
4	AI2+	Analogue input voltage or current	DIP switch 3 selects V or mA. Differential input if not connected to ground
5	AI2-	Analogue input c2 ommon	
6	24 Vout	24 V auxiliary voltage output	±10 %, 250 mA max.
7	GND	I/O ground	Ground for reference and controls
8	DI1	Digital input 1	Rin= 5 kohm min. 0 to 5 V = '0' 15 to 30 V = '1'
9	DI2	Digital input 2	
10	DI3	Digital input 3	
11	COM	Digital input common	Common for DI1 to 6. Can be disconnected from ground by removing link
12	24 Vout	24 V auxiliary voltage output	as terminal 6
13	GND	I/O ground	as terminal 7
14	DI4	Digital input 4	Rin= 5 kohm min. 0 to 5 V = '0' 15 to 30 V = '1'
15	DI5	Digital input 5	
16	DI6	Digital input 6	
17	COM	Digital input common	as terminal 11
18	AO1+	Analogue signal (+output)	DIP switch 2 selects V (0 to 10V) or I (0 to 20 mA)
19	AO1-	Analogue output common	
30	+24 Vin	24 Vdc auxiliary input	+24 Vdc, 100 mA, ±10% for backup power*
A	RS485 A (+)	Fieldbus communication	Differential receiver/transmitter; Use for BACnet MS/TP, or MODBUS RTU
B	RS485 A (-)		

“The control board can be powered externally by connecting an external power source to terminal 30. This voltage is sufficient for parameter setting and for keeping the control unit active. Note however that the measurements of the main circuit (e.g. DC-link voltage, Unit temperature) are not available when the mains is not connected.”

The Basic Relay Board (fitted as standard) has:

- 2 changeover relay output channel
- 1 thermistor input channel

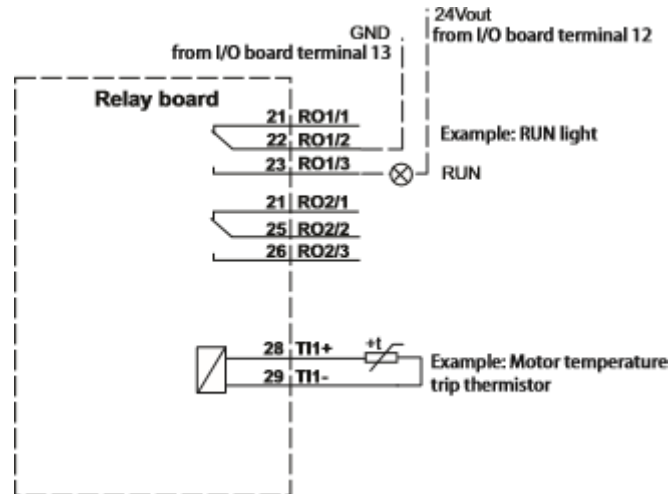

Terminal	Signal	Information	Factory Setting
21	RO1/1	Relay output 1 Normally Closed	RUN (active)
22	RO1/2	Relay output 1 Common	
23	RO1/3	Relay output 1 Normally Open	
24	RO2/1	Relay output 2 Normally Closed	FAULT (active)
25	RO2/2	Relay output 2 Common	
26	RO2/3	Relay output 2 Normally Open	
28	TI1+	Thermistor input	Motor temperature trip thermistor (PTC). If thermistor circuit is not used it must be short-circuited
29	TI1-		

An optional system network interface can be fitted into the VSD2H drive. It is plugged into slot D, and enables the unit to be monitored and controlled from supervisors, and from the controllers. There are the IQ system current loop Lan interface. NXNI (which provides a standard four wide current loop Lan terminal set), and the Ethernet interface, nxip. See NXNI data sheet TA200826 for details. Note that the NXNI allows the unit to be monitored by all controllers, but it can only be written to by IQ3, IQ4 or IQeco controllers.

## DIP Switch

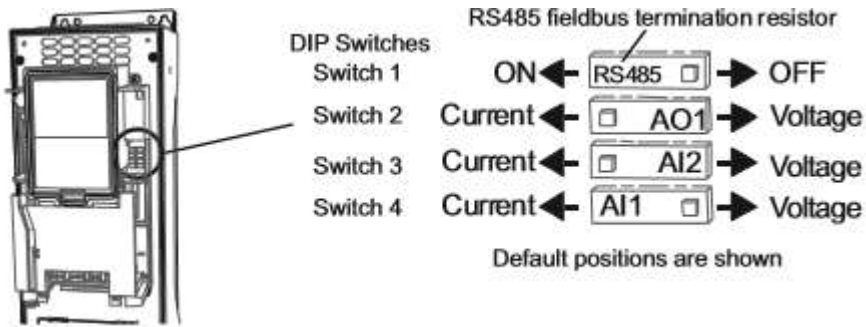

The 4 DIP switches have 3 functional positions, left, middle and right. The middle position is used for test mode. The switches are used to set the following parameters:

- Switch 1: RS485 fieldbus Terminator resistor, on or off (default off)
- Switch 2: Analogue Output 1, current or voltage (default current)
- Switch 3: Analogue Input 2, current or voltage (default current)
- Switch 4: Analogue Input 1, current or voltage (default voltage)

## Quick setup

A group of the parameters most commonly used during installation and commissioning.

## Monitoring

This enables parameters to be monitored only.

## Parameters

This enables the parameters to be edited. First the group of parameters is selected, then the individual parameter. The actual meanings of the parameters vary with the configuration being used.

## Diagnostics

This enables current and historical faults to be viewed, faults to be reset, and counters and software information to be viewed.

## I/O and hardware

This selects basic I/O, any additional boards in slots D or E (an NXNI or NXIP in slot D would be shown as OPTCO), Real time clock, the drive fan, keypad settings and fieldbus (RS485 or Ethernet) parameters.

## User settings

Language, application, parameter backup and restore to and from keypad.

## Favourites

(advanced commissioning keypad only) This enables the user to collect a set of parameters from any of the keypad menus.

## Digital Input Isolation

The digital inputs (DI1 to DI6) can be isolated from ground by removing a link on the control board as shown.

### Ethernet Connection

The Ethernet connection for BACnet over IP or MODBUS TCP is situated under the cover to the left of the control keypad, and the cable is run in a channel cut in the plastic flap. A shielded RJ45 connector should be used.

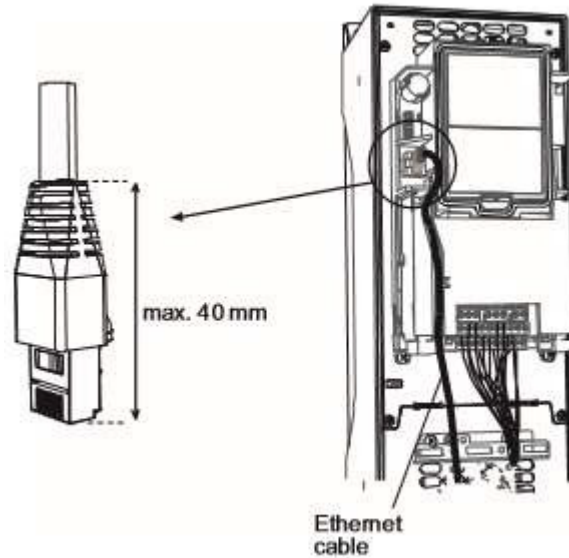

### RS485 Connection

The RS485 connection for BACnet over MS/TP or MODBUS RTU uses terminals A and B (A negative, B positive) in the basic I/O board terminal set. STP (Shielded twisted pair), type Belden cable 9841 or similar should be used. The terminator (see above DIP Sw 1) should only be switched on if the unit is at the end of the bus.

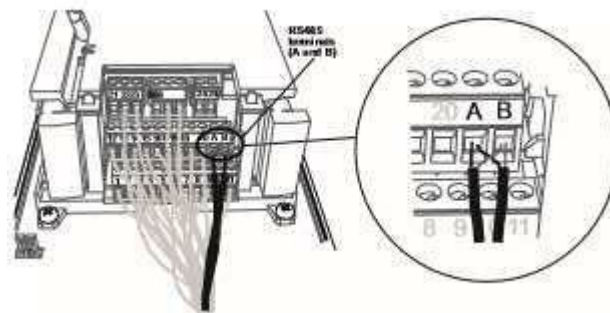

### Real Time Clock

The VSD2H has a real time clock with timer functions. The unit comes complete with timer functions. The unit comes complete with a Real Time Clock battery installed to maintain the time during power failure.

## Integrated RFI-filter

The units have integrate RFI filters, enabling them to comply with EN61800-3 category C2 (suitable for public electricity networks such as buildings).

## Integrated DC Choke

The units are equipped with DC chokes to reduce harmonics (THD), enabling them to comply with EN61000-3-12,

## Integrated Stress Removal

Stress removal and 360° grounding of power cables inside the unit with clamps. No need for extra glands.

## External Keypad

The External Keypad can be used for setting the frequency converter's parameters, reading status data, and giving control commands. It is detachable and can be operated externally being connected via a cable to the main unit. There are two accessory kits available.

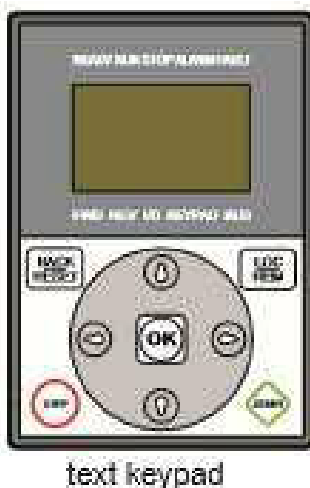



### ACC/VSD2H/Hand Held Kit

This enables the keypad to be detached from the unit and to be used as a hand held unit connected to the VSD by a 2 m cable.

### ACC/VSD2H/Door Mounting Kit

This enables the keypad to be detached from the unit and to be mounted in the panel door connected to the VSD by a 2m cable.

The standard text keypad features an alphanumeric display with seven indicators for run status (READY, RUN, STOP, ALARM, FAULT, FWD, REV), and three indicators for control source (I/O, KEYPAD, BUS). There are also two text lines displaying description (of menu, value or fault) and location (reference to menu and parameter) or value (numerical, textual values).

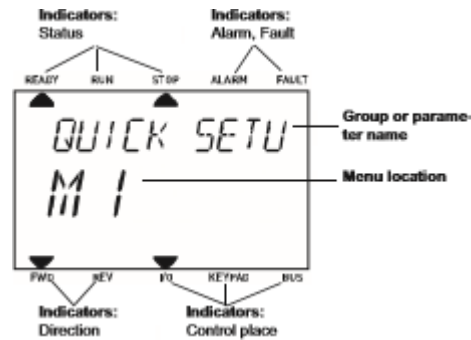

A replacement advanced commissioning keypad is available as an accessory (ACC/VSD2H GRAPHIC DISPLAY). The commissioning keypad can also be used to store the parameter settings and transport them to another drive (ref: M6.5). The top row is the drive status field, and the second row is the location field describing the position in the selection menu. The remaining three rows can be used for display of information. The commissioning keypad has extra features (help and information displays, favourites, multi-monitor of 9 selected values).

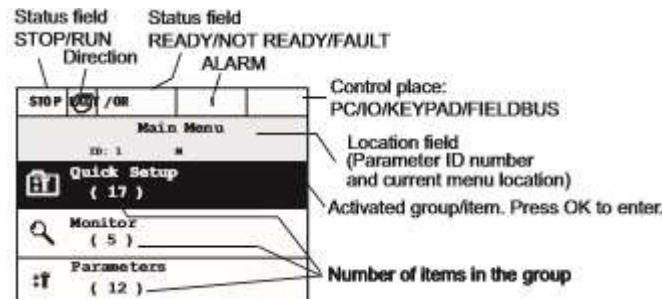

## Hardware

The keypad has nine buttons which are used for controlling the drive, setting parameters, and monitoring values. The buttons are the same for both types of keypad.

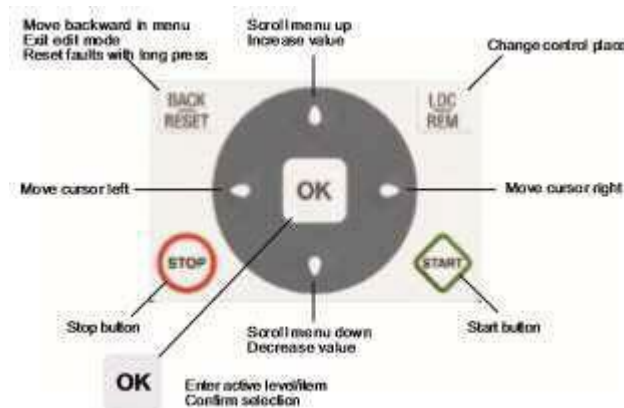

The keypad is the control source by default (i.e. Local) but it can be changed to remote at any time by pressing the LOC/REM button. (The control source has to be changed to Remote/Fieldbus for the NXNI or NXIP to control the drive.)

The main menu consists of 7 individual items which are browsed using up and down buttons, the submenus under these menus are then browsed by selecting OK.

Quick setup:

A group of the parameters most commonly used during installation and commissioning.

**Monitoring:** This enables parameters to be monitored only.

**Parameters:** This enables the parameters to be edited.

First the group of parameters is selected, then the individual parameter. The actual meanings of the parameters vary with the configuration being used.

**Diagnostics:** This enables current and historical faults to be viewed, faults to be reset, and counters and software information to be viewed.

**I/O and hardware:** This selects basic I/O, any additional boards in slots D or E (an NXNI or NXIP in slot D would be shown as OPTCO), Real time clock, the drive fan, keypad settings and fieldbus (RS485 or Ethernet) parameters.

**User settings:** language, application, parameter backup and restore to and from keypad.

**Favourites:** (Advanced commissioning keypad only) This enables the user to collect a set of parameters from any of the keypad menus.

**Digital Input Isolation:** The digital inputs (DI1 to DI6) can be isolated from ground by removing a link on the control board as shown

**Ethernet Connection:** The Ethernet connection for BACnet over iIP or MODBUS TVP is situated under the cover to the left of the control keypad, and the cable is run in a channel cut in the plastic flap. A shielded RJ45 connector should be used.

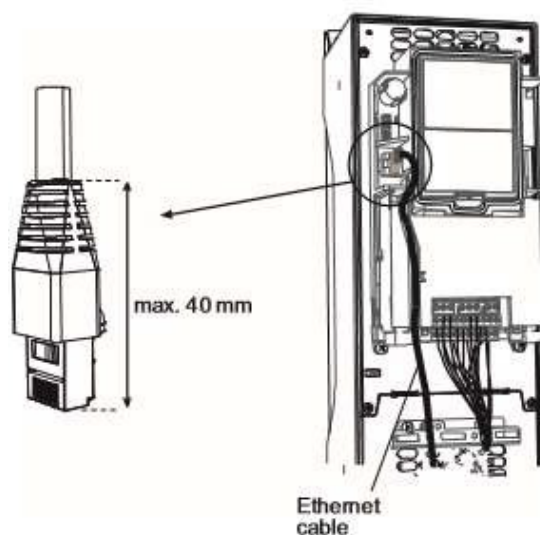

**RS485 Connection:** The RS485 connection for BACnet over MS/TP or MODBUS RTU uses terminals A and B (A negative, B positive) in the basic I/O board terminal set. STP (Shielded Twisted Pair), type Belden cable 9841 or similar should be used. The terminal to ground (see above DIP Sw 1) should only be switched on if the unit is at one end of the bus.

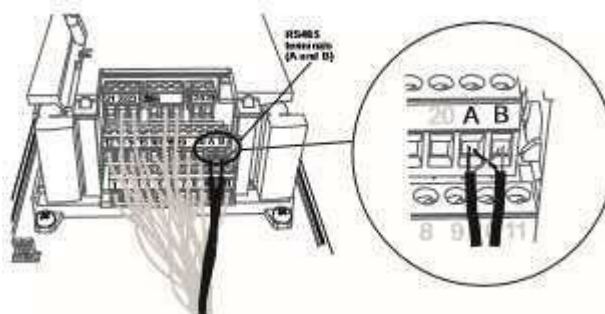

**Real Time Clock:** The VSD2H has a real time clock with timer functions. The unit comes complete with a Real Time Clock battery installed to maintain the time during power failure.

**Integrated RFI-filter:** The units have integrated RFI filters, enabling them to comply with EN61800-3 category C2 (suitable for public electricity networks such as buildings).

**Integrated DC choke:** The units are equipped with DC chokes to reduce harmonics (THD), enabling them to comply with EN61000-3-12.

**Integrated stress removal:** stress removal and 360° grounding of power cables inside the unit with clamps. No need for extra glands.

---

## Quick Setup

On initial power up, the start-up wizard will prompt for:

- Language
- Daylight saving
- Time, day, year
- Run start-up Wizard

(Y/N) If yes:

- Process (pump or fan)
- Motor Nominal Speed (range 24 to 19200 rpm)
- Motor Nominal Current (range depends on unit)

There are other mini-wizards that can be used for setting the following:

- PID: Three term control for motor or external device by way of I/O.
- Pump and Fan Cascade: Cascade control of several pumps or fans.
- Resonance Sweep: For elimination of possible resonance points in the system.

The quick setup menu, mentioned above, enables access to the parameters most commonly used during installation and commissioning including access to the start-up, PID and pump and fan Cascade wizards.

## Uninterruptible Operation and Energy Saving

Over temperature ride-through: Automatically adjusts switching frequency and/or speed of the motor to adapt to unusual increase in ambient. The benefit of this is uninterrupted operation.

RTO – Ramp Time Optimizer: When problematic areas are identified in acceleration or deceleration the drive automatically expands the times needed for this to avoid mechanical stress to the system. The benefit of this is the decreased mechanical stress to the system.

Trip free output switching: Ensures trip free operation when an output switch (e.g. safety switch) is operated between the motor and the VSD. Truly intelligent and highly reliable function to ensure better functionality than with any other VSD. The benefit of this will be Uninterruptible operation.

Energy Saving function (Flux Optimization): Flux Optimization automatically minimizes energy consumption. The benefit will be a 5% increase in energy savings.

Configurable Auto Reset function: Auto restart function can be configured to make VSD restart automatically once fault is addressed. The benefit of this is uninterrupted operation.

## VFD and Motor Control

**Single Input Control:** Analog signal rising edge can be used to start the device without additional start signal to a digital input. The benefit of this is cost and time savings.

**Flying start:** Ability to get an already spinning fan under speed control. The benefits of this will be improved performance, very important in clean room production.

**Automatic torque boost function:** Boosts initial voltage to start high inertia fans. The benefits of this is it avoids tripping and enables smooth starts also to high inertia loads.

**High Switching Frequency:** The VSD2H is capable of providing the maximum power with high switching frequency. The benefit of this is low audible noise from the motor.

**Prohibit frequency:** Overriding the critical frequencies to avoid resonance. Can be set with the help of resonance sweep wizard. The benefit of this will be the elimination of resonance.

**Maintenance counters/alarms:** The drive can be programmed to notify on upcoming maintenance for the system or the drive itself. The benefit of this will be the reliability.

**Temperature-controlled fans:** Fan stops operating when not needed. The benefits of this is less audible noise from the VSD itself, and also energy savings.

## Advanced HVAC Control

**Time based control:** With the help of the real time clock and calendar functionality the drive can be programmed to perform functions based on time. The benefits of this will be cost savings and also flexibility.

**Inbuilt PID Controller:** Normal and Inverse Regulation, Delta P regulation with 2 standard pressure transmitters, Feed forward control, less wiring since sensor normally close to inverter. The benefit of this would be the cost saving and faster response to process closed loop.

**Sleep Mode:** Shutting down the motor, when no demand. The benefit of this will be energy savings.

**Pressure loss compensation:** For compensating e.g. wrongly placed sensor in the system. The benefit of this will be a time and cost saving. **Pump Soft Fill:** Feature to prevent the overpressures when filling empty pipe work. The benefit of this will be a longer lifetime of the system.

**Fire override mode:** Keeps fan/pump running in case of fire. This is a legal requirement.

**Pump and Fan Cascade control with full auto-change:** Controls total pumping system with several parallel pumps by equally sharing the load. Also the master pump can be included in auto-change loop. The benefits of this will be the longer lifetime of the system, also the cost savings will be a benefit.

## Software

Windows based PC utility tools are available for making the use of the Trend VSD2H as easy and convenient as possible. The tools facilitate installation, commissioning and maintenance. The software is self-documenting from its integral help file. The minimum requirement for using the software is a PC and a USB to RS485 interface cable (e.g. ACC/VSD2H/USB-PC/CABLE, 3 m), to be connected to the RS485 terminal behind the control panel.

Drive care PC tool: The drive Care tool is easy-to-use commissioning software for the control of the VSD2H. It enables the following:

- Setting up parameters with the PC
- Saving settings to the PC
- Creating commissioning documentation
- Comparing parameters settings
- Monitoring view with graphics
- Diagnostics
- Controlling the drive from the PC.

This tool also includes the 'Loader' tool which enables the downloading of firmware or applications.

Note that the drive configuration can be loaded from one drive into the advanced commissioning keypad (ACC/VSD2H/Graphic Display), and downloaded into another drive.

---

## SISO – Safety Isolators/Switch-disconnectors

### Switches & Sensor

#### Features

- Electrical range 230V-690V, 1-3 phase, 50-60Hz, 0-63A
- Enclosure IP66 Grey RAL 7035
- Mechanically interlocked with 3 x padlock to 'off' apertures
- Early breaker fitted to all units as standard. Three and six pole/wire versions available
- Three and six pole/wire versions available
- Two entries top and bottom 20/25A M20 40/63A M20/25
- Stainless steel facia screws
- Two earth continuity screws in each enclosure

#### Description





All fans and drives should have a correctly rated lockable Isolator switch instead in the power input circuit to provide full electrical isolation. This is vital for safe installation, operation and maintenance.

Many modern drives also require an early break signal so that a graceful full power off can be achieved without damage to sensitive electronics. Early break is included in all SISO Isolators. Isolators are provided with mechanically interlocked IP56 standard.



## Range

Model	Description	Part
<b>SIS025-3</b>	<b>Isolator 3P 25A+2EB</b>	<b>EA002000</b>
SIS040-3	Isolator 3P 40A+2EB	EA002001
SIS063-3	Isolator 3P 63A+2EB	EA002002
SIS025-6	Isolator 6P+2EB 25A	EA002003
SIS040-6	Isolator 6P+2EB 40A	EA002004

Attribute	Unit	SIS025-3	SIS040-3	SIS063-3	SIS020-6	SIS040-6
Rated thermal current	A	25	40	63	20	40
Rated insulation voltage	V	690	690	690	690	690
Rated impulse voltage	kV	6.0	6.0	6.0	6.0	6.0
Rated operational power (3 phase AC)	kW	11.0	15.0	25.0	7.5	15.0
Rated short withstand current (1 sec)	A	500	600	1300	250	800
Terminal type						
Flexible cable	mm <sup>2</sup>	6.0	6.0	16.0	2.5x2	6.0x2
Rigid cable	mm <sup>2</sup>	10.0	10.0	25.0	2.5x2	10.0x2
Tightening torque	Nm	1.2	1.2	1.2	1.0	1.0

Auxiliary Contacts			
Rated insulation		V	690
Rated thermal current		A	10
Operational current	100V	A	8
	220-240V	A	8
	380-400V	A	3
	660-690V	A	1
Max. conductor size		mm <sup>2</sup>	1.5
Tightening torque		Nm	0.6



## Commissioning

## Plug / SISW / DIDW Fans - Motors – Drives

Access is by hinged or lift off panels. Catches are hidden quarter turn cams, tool or key operated.

Wiring to the motor(s) should be carried in flexible armoured conduit through screwed gland(s) fitted in holes(s) drilled by the installer/user. **NEVER THROUGH ACCESS DOORS.**

Motors may be 240/1/50 or 415/50 TEFC, flameproof, super silent, single speed, dual speed, regulative or non-regulative D.O.L. or Star Delta. **DO NOT** attempt to wire the motor without reference to the correct wiring diagram issued with the unit.

Starters **MUST** have thermal overload cut outs and single phasing prevention devices.

### Belt Drives

Slacken belt tensioner, remove belts, check impeller rotates freely and fan scroll is free of obstructions. Remove locking bolts and shipping braces, if fitted, to protect vibration isolators during transport.

Adjust jacking self-levelling steel spring vibration isolators as instructions until floating and damped. Check rubber in shear anti-vibration mounts for condition, tightness and free operation –bounce.

Inspect all bolts on motor, fan and frame for tightness. Test run motor for condition and correct rotation.

Replace belts and check pulleys are correctly aligned as illustrated.

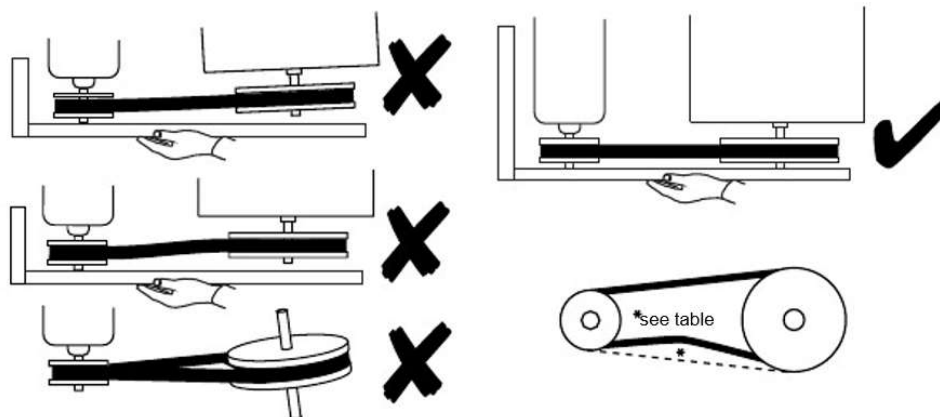

Adjust the belt tension according to the table

The lowest belt tension at which slip does not occur under load gives longest belt and bearing life.

Belt Section		SPZ	SPZ	SPA	SPA	SPB	SPB	SPC	SPC
Small pulley diameter	Min	67	100	100	140	160	236	224	375
	Max	95	140	132	200	224	315	355	560
KG force for 16mm* defl'n / metre span	Min	1.0	1.5	2.0	2.8	3.5	5.1	6.1	9.2
	Max	1.5	2.0	2.7	3.5	5.1	6.6	9.2	12.2

With all access panels in place, components installed and the cutting system complete, connected and commissioned, check that measured full load current is less than motor nameplate full load current. Check that starter overload setting is correct and that single phasing protection is functioning. If any problems occur refer to Fault Finding Section of this manual.

The complete ductwork system should be proportioned to CIBSE - ASHRAE recommended procedure. The Volume should be measured and if outside CIBSE recommendations or specified tolerances then;

Installer / commissioning engineer should submit full commissioning data to ECE.

ECE will calculate new fan speed required to achieve design volume and recommend pulley(s) & belt(s) sizes required to achieve new fan speed.

Installer/commissioning engineer should then:

- Purchase new pulleys and belts available locally from nationwide stockiest.
- Change pulley(s) and belt(s) on site
- Re-measure volume
- Recheck proportion and volumes to air terminal devices

ECE site operatives are available for changing belts and pulleys on site at extra cost if required.

*"Rotating standby motors generate electricity even when isolated from the mains. If the motor is being rotated by the fan do not touch the terminals even if the motor is isolated"*

The most common cause of incorrect fan volume is over estimation of system resistance. Please check this before contacting ECE.

Unless specified otherwise fans are belted to give specified volume with clean filters.

Where the specification calls for design volume with dirty filters we recommend the incorporation of pressure activated constant volume control since selection of the fan(s) at final system resistance could result in considerable excess volume initially.

Excess volume can cause:

- Coil off temperature, hence room supply air temperature, hence room temperature not being achieved
- Water carryover and flooding
- Motor overload and burnout
- Increased fan noise levels
- Turbulence and excitation of duct walls resulting in noise and vibration problems
- Noise regeneration at changes of direction, volume control dampers and air terminal devices
- Reduced filter life

Gross under volume can cause coil sweating, freezing and motor burn out.

Anti-Vibration Mountings  
Rubber Mountings

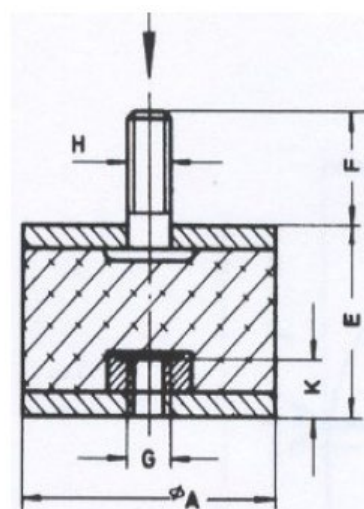

A	E	G	H	F	K
20	25	M6	M6	15	6
25	15	M6	M6	18	6
25	20	M6	M6	18	6
25	30	M6	M6	18	6
30	30	M8	M8	20	8
40	30	M8	M8	23	8
40	40	M8	M8	23	8
50	35	M10	M10	28	10
50	40	M10	M10	28	10
50	50	M10	M10	28	10
75	50	M12	M12	37	12
100	40	M16	M16	45	16

### Spring Mountings

Isotop® SD steel spring vibration isolators consist of two spring elements with M 10 internal thread and a cylindrical screw spring designed according to DIN EN10270-1: 2001. Height adjustment is done via a threaded rod M 10 with three nuts and three locking washers for level adjustment and weight distribution. Corrosion protection: Optional corrosion protection, either galvanized or cataphoresis coated (KTL).



Isotop SD, galvanized



Isotop SD KTL

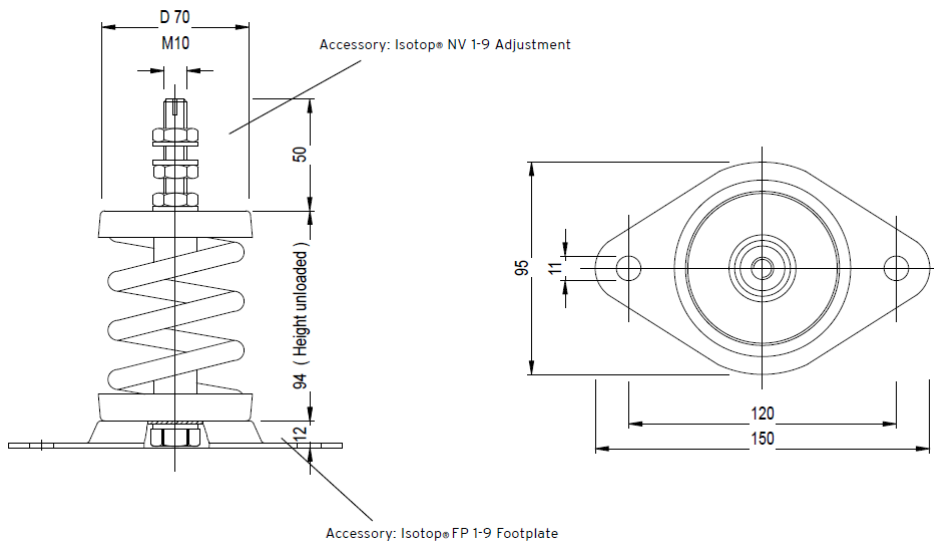

### Selection Table

DESCRIPTION	REF. NO., GALVANISED	REF. NO., KTL (BLACK)	NOMINAL RANGE min./max.	SPRING RATE
Isotop® SD 1	45000011	45000001	120 N – 265 N	7.93 N/mm
Isotop® SD 2	45000012	45000002	195 N – 380 N	12.90 N/mm
Isotop® SD 3	45000013	45000003	300 N – 670 N	20.16 N/mm
Isotop® SD 4	45000014	45000004	475 N – 1,200 N	31.64 N/mm
Isotop® SD 5	45000015	45000005	720 N – 1,700 N	48.07 N/mm
Isotop® SD 6	45000016	45000006	1,130 N – 2,700 N	75.56 N/mm
Isotop® SD 7	45000017	45000007	1,815 N – 3,800 N	121.03 N/mm
Isotop® SD 8	45000028	45000008	2,800 N – 5,200 N	187.10 N/mm
Isotop® SD 9	45000029	45000009	3,750 N – 6,400 N	234.30 N/mm

### Checking Label Positioning



The positions of the Danger & Caution labels, these labels will always be positioned on the fan section doors. Should for any reason these labels not be in position they can be obtained from ECE



The positions of the Caution Hot Surface labels, these are positioned on electric heater batteries and gas burners where the surface on the outside of the AHU will be HOT. Should for any reason these labels not be in position they can be obtained from ECE

### Hinged Handle Access

When working internal to the AHU you must remove the access doors completely to stop personnel getting locked inside.

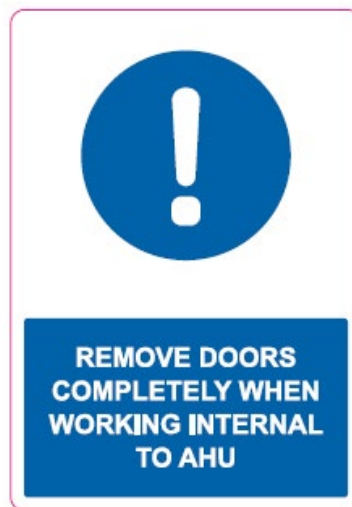

### Compression Latch-Hinge

#### Product Details

- When the door is closed, the latch is adjustable (3mm) to achieve perfect alignment
- Compression (5 mm) with low opening & closing force
- Door or panel can be removed by unlatching the handles on both sides
- Right or left hinged
- Hinge 180° opening angle
- Available with or without pressure relief

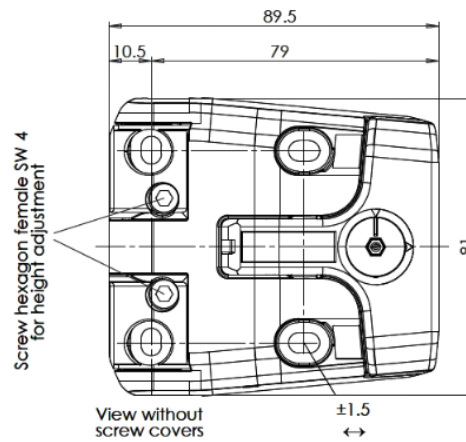
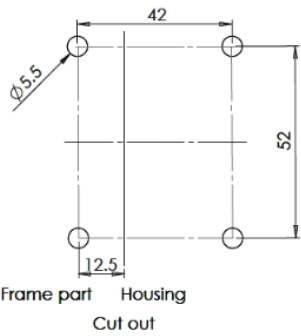
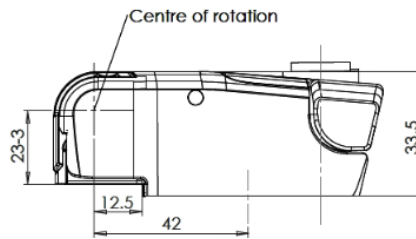
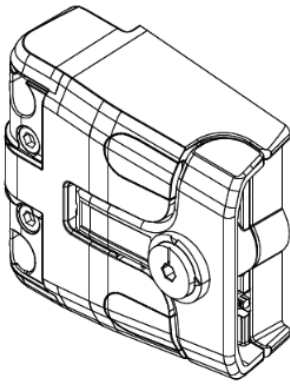

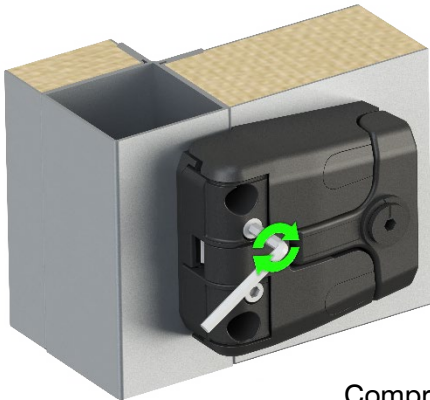

Compression  
Latch-Hinge locked

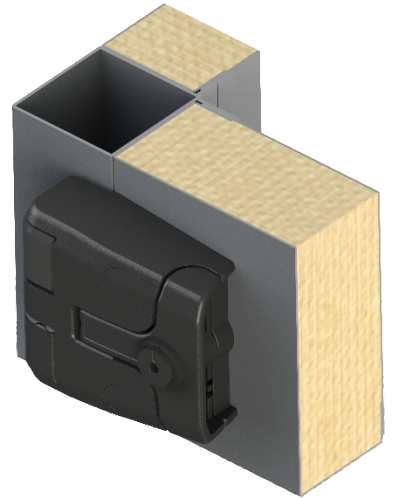

Compression adjustable  
on the frame part

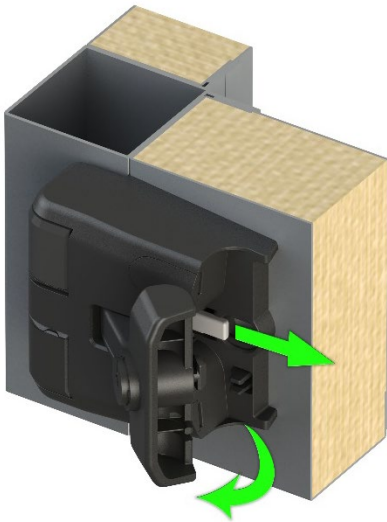

Latch-Hinge with pressure  
relief, handle unlocked

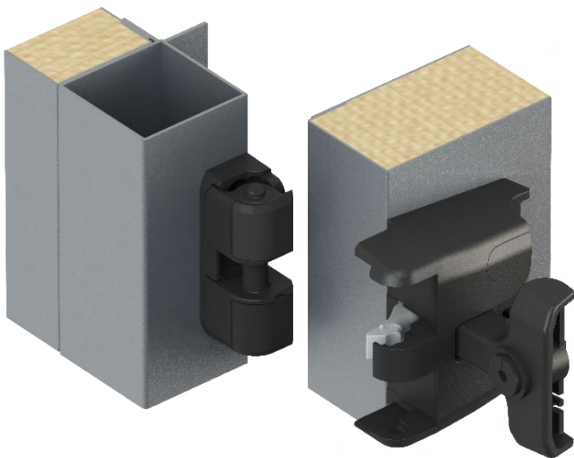
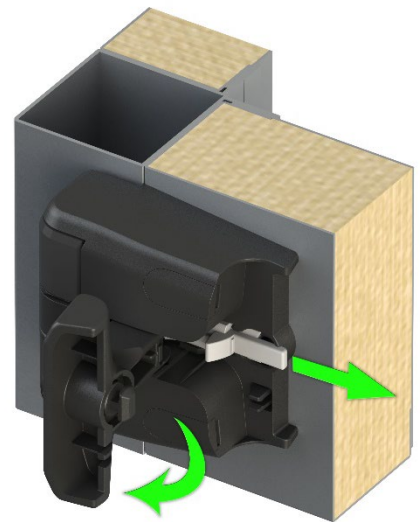

Latch-Hinge open

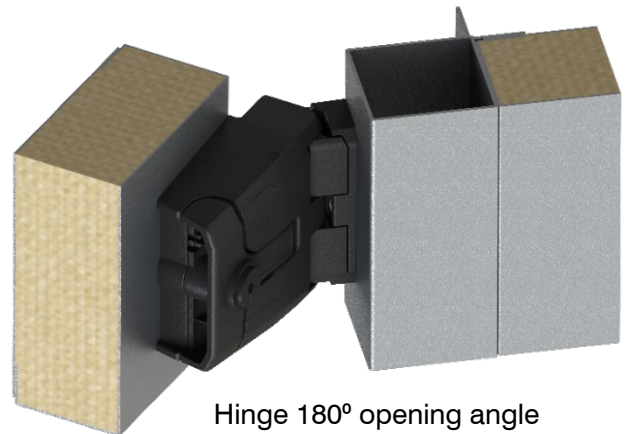

Hinge 180° opening angle



## Servicing Filters

- Remove open side access doors (unless special access).
  - Thoroughly clean system.
  - Install temporary filters (gauze bags etc) on inlet discharge points.
  - Replace and close access doors.
  - Blow out system.
  - Remove contaminated temporary filters.
  - Replace filters, check sealing for bypass.
  - Replace doors.
- 
- ✓ Panel filters - Check airflow direction arrows.
  - ✓ Absolutes - Ensure pre-filters fitted, check sealing.

Maximum operating conditions	Continuous	Short period
Glassfibre panels	110°C 80% RH	110°C 80% RH
Soft fibre panels	49°C 80% RH	49°C 80% RH
Bag standard	100°C 80% RH	100°C 89% RH
Bag extra fine superfine	100°C 100% RH	100°C 100% RH
Fire resistant panel (BS.2963)	250°C	500°C
Absolute corrosion resistant	66°C 100% RH	120°C
Absolute medium temperature & humidity	70°C 80% RH	120°C
Absolute fire resistant & self-extinguishing	250°C 100% RH	500°C

Always replace media with **IDENTICAL** media.

Install fan run-on control with high temperature heating mediums such as steam or electricity.

Pressure switches across filters only indicate blocked filters NOT low airflow due to other reasons e.g. blocked inlets dropped fire dampers.

Install bag or absolute filters after the fan (with discharge plenum) to guarantee efficiency. Pre filters are still necessary to protect the coils. Activated carbon filters must have coarse and fine pre-filters.

---

## Mixing Boxes – Separation Boxes - Shut off VCD's - HRD's



Hand operated with locking quadrant

Check:

- Free action of the damper blades and arm before setting at the required angle.

Motorised

Remove links and check:

- Motor bolts and platform tight.
- Electrical supply and connections correct.
- Motor operates freely and in correct direction.
- Dampers move freely.
- Reconnect link(s) and adjust for required damper movement and check
- Links are not adjusted so that motor attempts to push dampers BEYOND fully open or fully closed position in as this can damage motor linkages and bearings.

## Coils

General checks:

- Coils installed in correct order for psychometrics.
- Fin conditions, comb out if necessary.

Water coil checks:

- Air and water are in counter flow.
- Flow pipe work with drain cock fitted is to lowest connection.
- Return pipe work with vent is from highest connection.
- Drains at the lowest point, vents at highest point.
- Frost protection exists for low ambient airflow or shut down conditions.

### Coil Connections

Ensure connections to coils are bottom inlet and top outlet, this arrangement ensures thermal siphoning aids flow. Performance will be limited if these connections are made the wrong way.

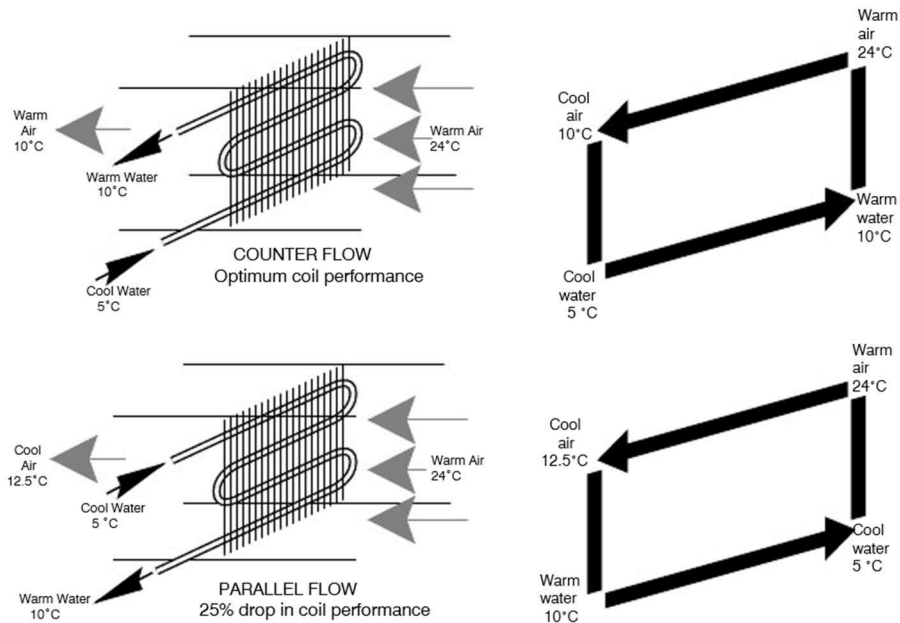

Refer to following section for full details on coil and condensate drain connections

### Setting Water Flow through Coils

Open all manual valves fully – including the bypass valve on the three port control valves diverting port. Ensure that the three port control is set to pass 100% flow through the air handling unit coil.

With the aid of a screwdriver open the two small inbuilt valves either side of the flow indicator window on the main commissioning unit. The main commissioning unit is sited in the main return pipe (these small valves allow water to pass through the indicator window to enable flow rate to be observed).

Set the flow rate through the coil by rotating the larger valve on the main commissioning unit to restrict the water flow until the desired flow rate is indicated in the window. Once this valve has been set DO NOT adjust it again.

Move the three port control valve into the 100% bypass position.

Slowly close the secondary commissioning valve (sited on the three port control valves bypass port) at the same time observe the flow rate being indicated in the window of the main commissioning valve. Continue closing this valve until the same flow rate reading as before is obtained.

Conclude by closing the two small integral valves wither side of the indicator window on the main commissioning valve.

The system is now balanced.

Coil Condensate Drains  
Draw Through Units and Blow Through Units  
with negative pressure (depression at trap)

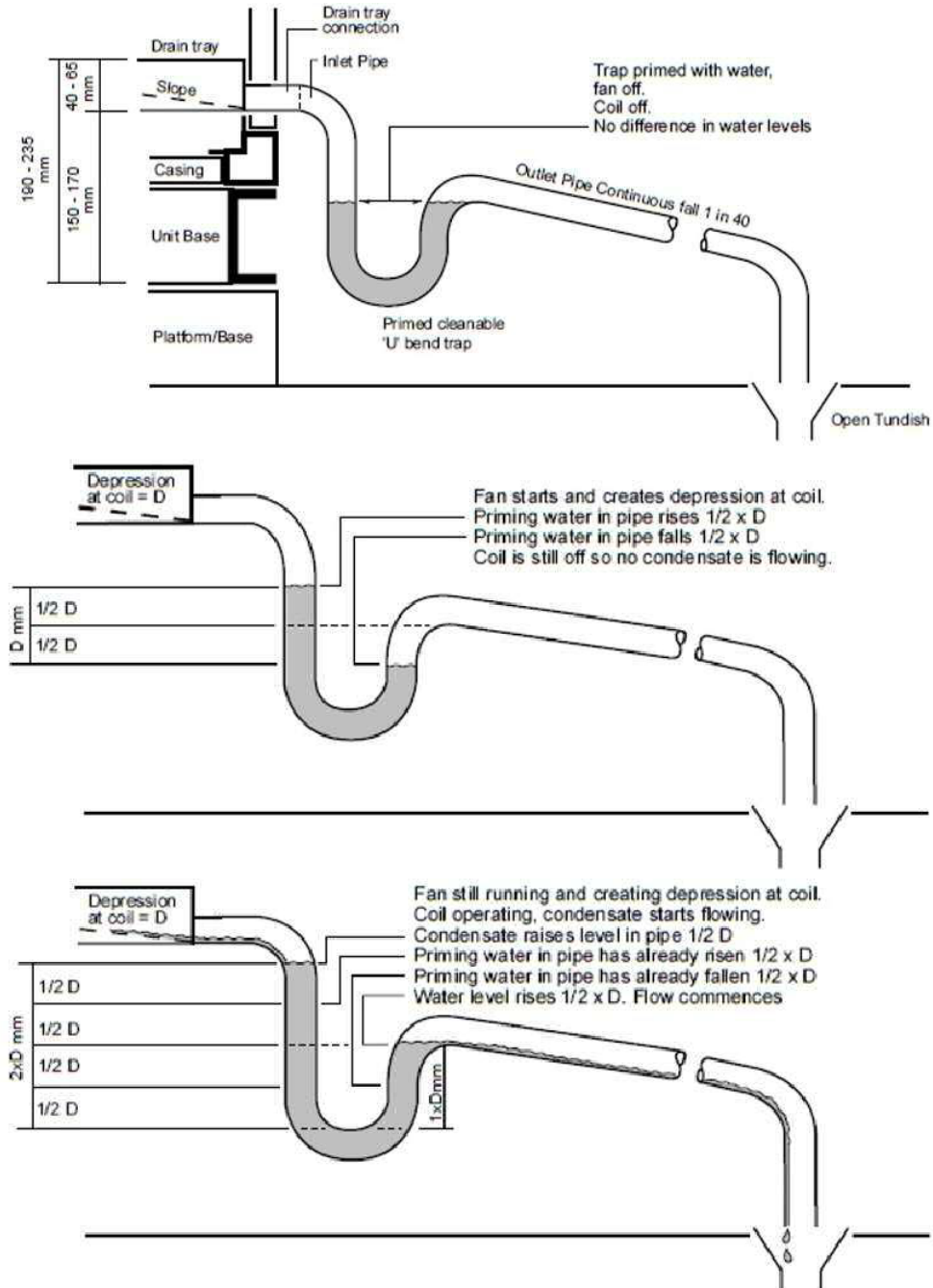

10pa difference in pressure = 1mm difference in water level  
i.e. 190mm = 1900pa depression -- 235mm = 2350pa depression

Blow through units with positive pressure at trap

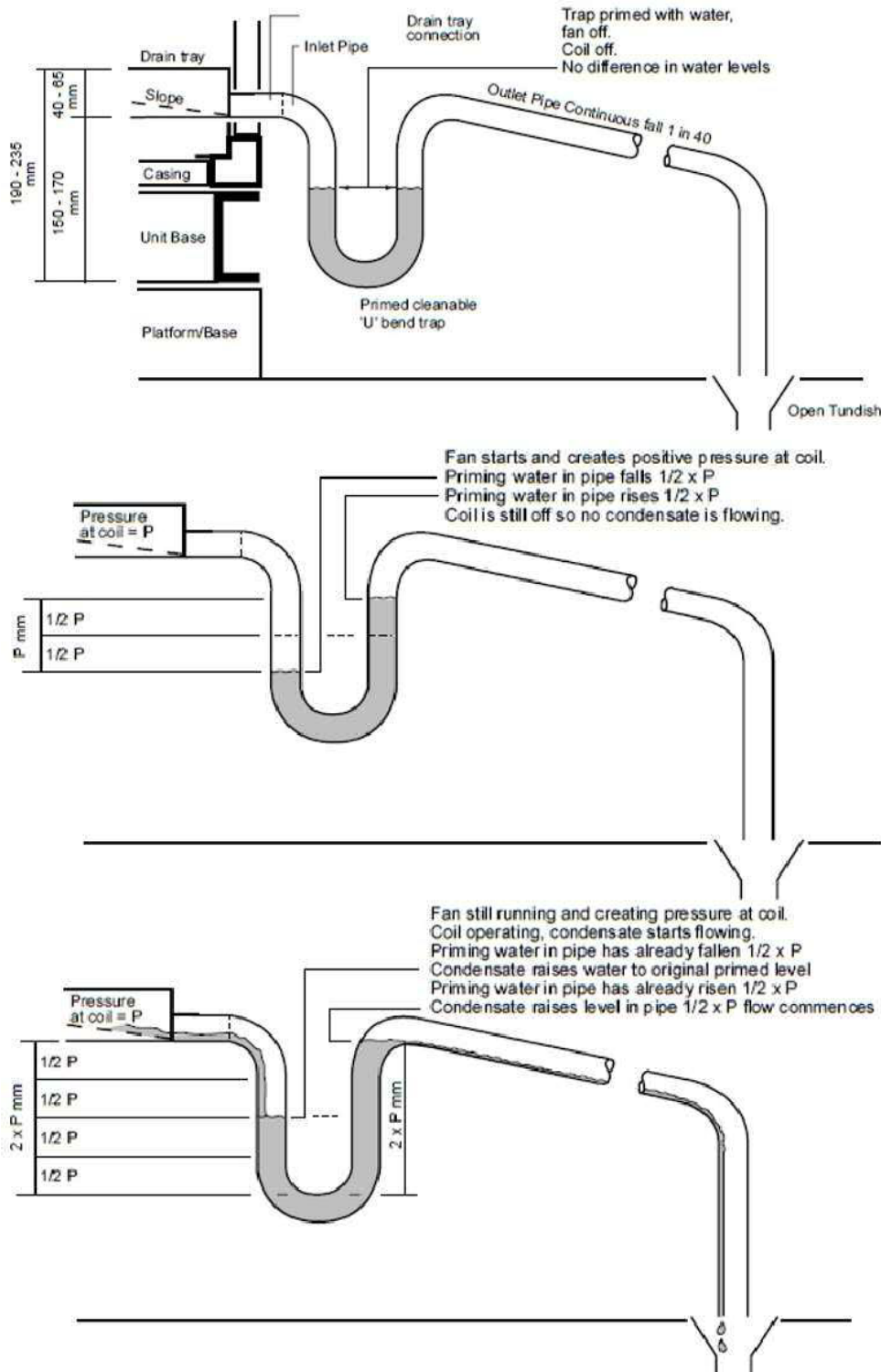

10pa difference in pressure = 1mm difference in water level  
i.e. 190mm = 1900pa depression -- 235mm = 2350pa depression

## Coil Condensate Faults

### Draw Through

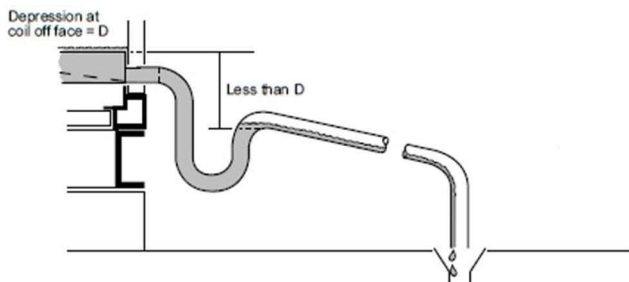

Inadequate trap differential resulting in condensate drain tray overflow and flooding

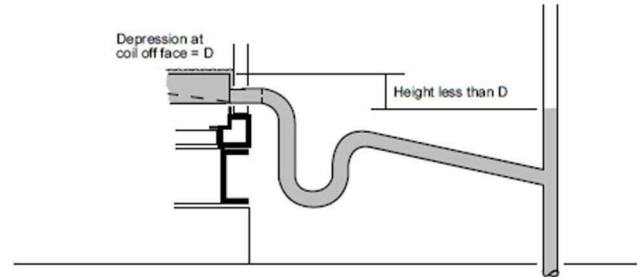

Not draining into an open tundish but connecting to a full pipe resulting in condensate drain tray overflow and flooding

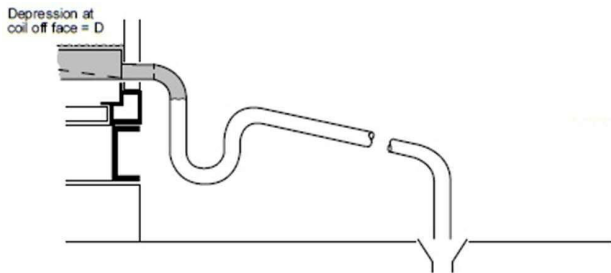

Trap not being primed with water resulting in condensate drain tray overflow and flooding

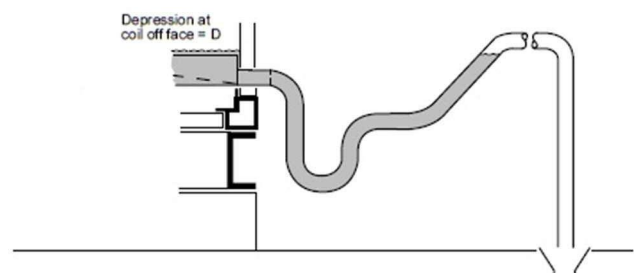

Reverse pipe slope resulting in condensate drain tray overflow and flooding

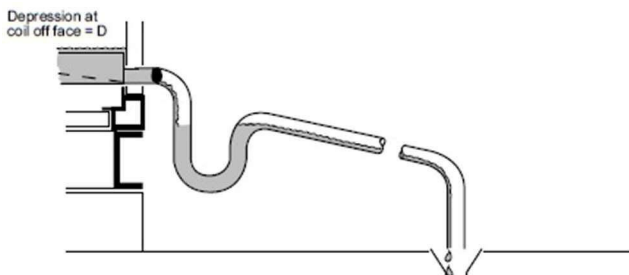

Blocked pipe connection(s)  
Partial block = some flow resulting in condensate drain tray overflow and flooding

## Blow Through

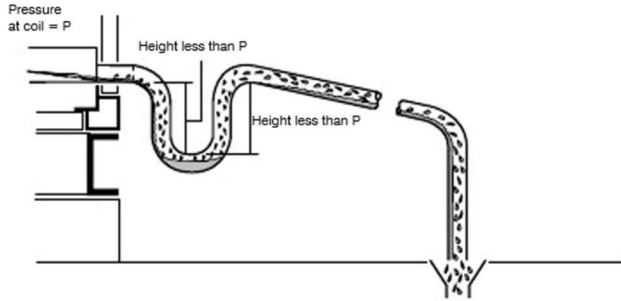

Inadequate trap differential resulting in priming water blow-out "splutter" and air leakage

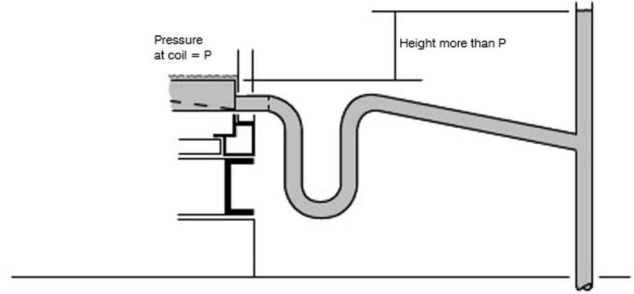

Not draining into an open tundish but connecting to a full pipe resulting in condensate drain tray overflow and flooding

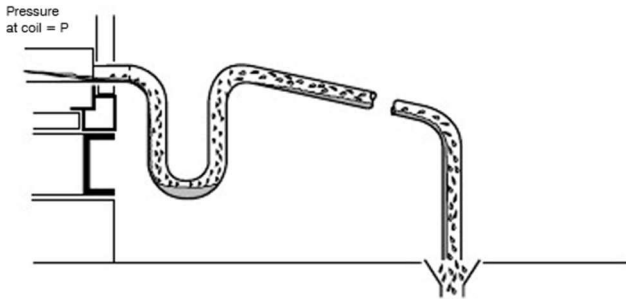

Correct trap but not primed with water resulting in condensate blow-out "splutter" and air leakage

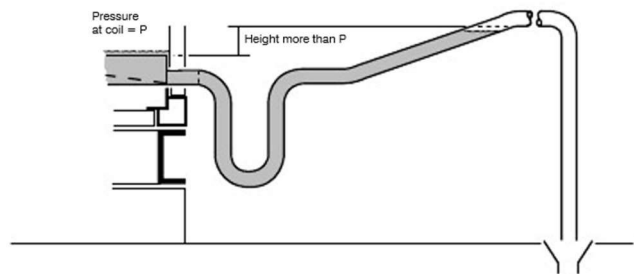

Reverse pipe slope resulting in condensate drain tray overflow and flooding

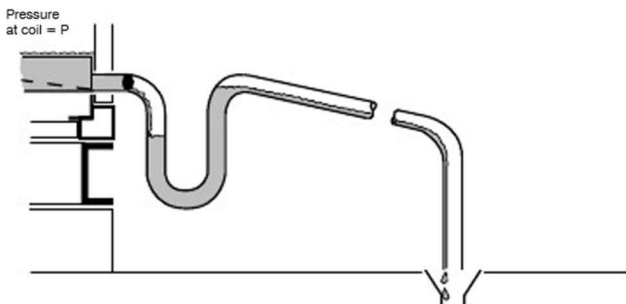

Partially or fully blocked pipe connection(s) resistance through blockage greater than P resulting in drain tray overflow and flooding.  
Partial block = some flow

## Draw through coils with condensate pump

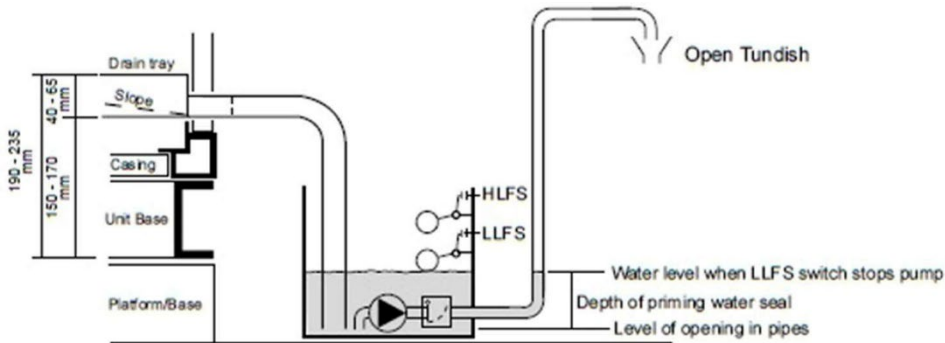

Pump sump primed with water  
Fan off  
Coil off  
No difference in water levels

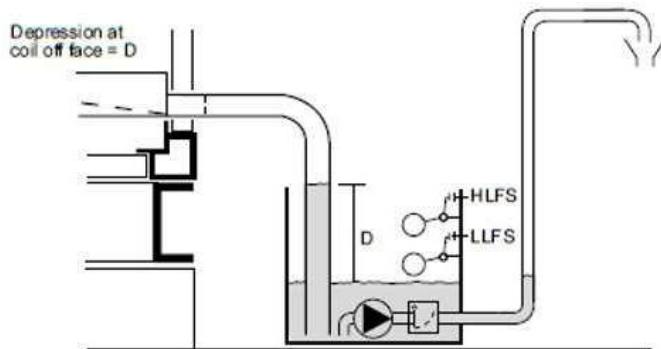

Fan starts and creates depression at coil  
Priming water in pipe rises 1 x D  
Priming water in sump falls  
$$1 \times D \times \frac{\text{Area of pipe}}{\text{Area of sump}}$$
  
Coil is still off so no condensate is flowing

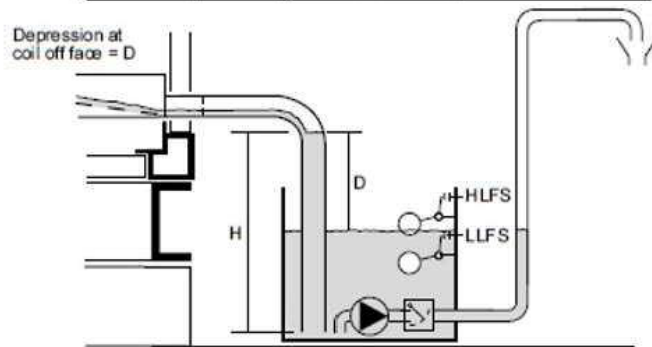

Fan still running and creating depression at coil  
Coil operating, condensate flowing  
Water level in pipe rises  
Water level in sump also rises until HLFS operates  
Pump starts

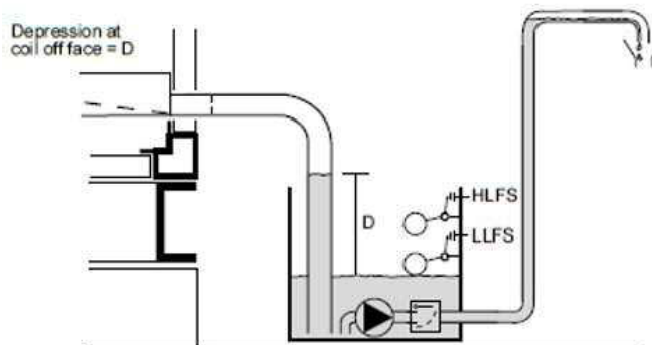

Pump runs  
Water levels fall until LLFS breaks  
Pump stops

H = depression at off face of cooling coil + difference in level between HLFS operating and pipe openings  
10pa difference is pressure = 1mm difference in water level  
i.e. 1900pa depression - 235mm = 2350pa depression



## Chilled Water Cooling and LP Hot Water Heating Coils

### Bypass Circuit

Tightly closing three-way valves are required as the regulating valves. At nominal flow the pressure drop across the valves (pv100) should range from approximately the same value to about double the value of the pressure drop across the heating load branch at nominal flow.

The balancing valves are used to adjust the water volumes for the individual heating circuits.

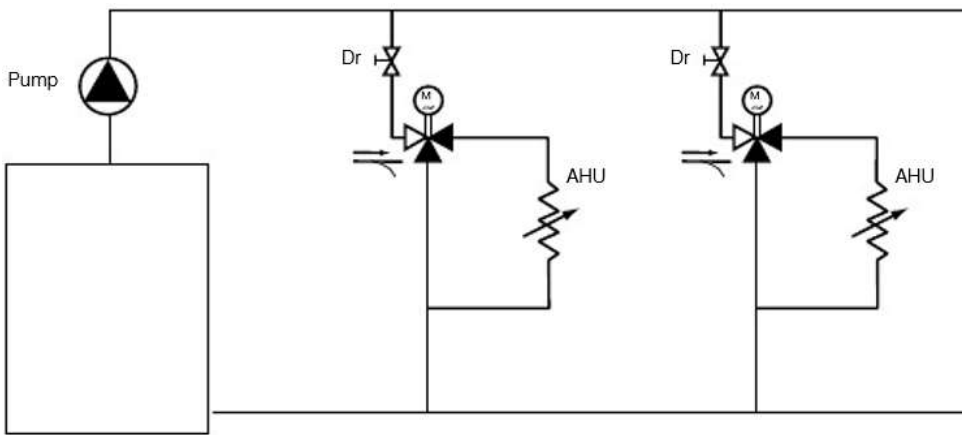

### Mixing circuit using three-way mixing valves.

Slipper valves can generally be used. The nominal size is usually chosen equal to the nominal size of the pipe. However, from the point of view of hydraulics, slipper valves one size smaller than the nominal size of the pipe are preferable.

In systems where the pressure difference between A and B exceeds approximately 0.8 mWG, it must be checked that the leakage losses of the slipper valves remain within tolerable limits. If this is not the case, seat valves are to be used.

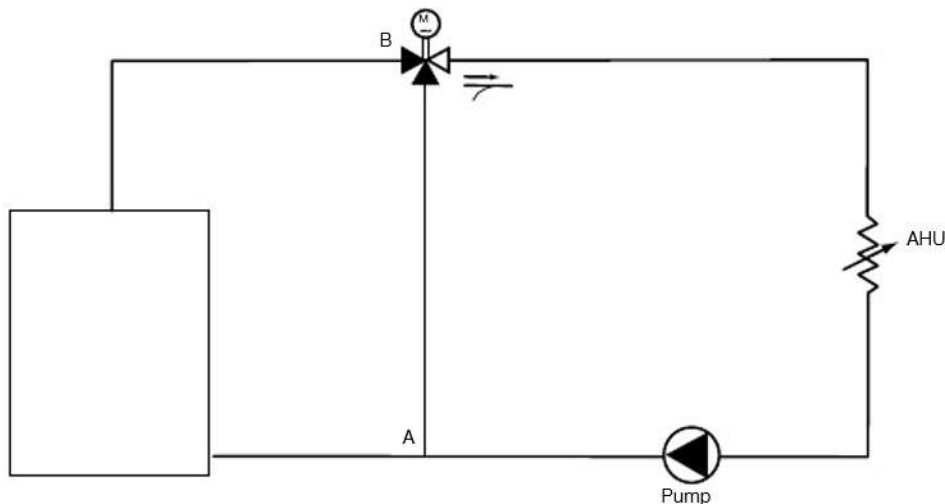

## Chilled Water Cooling Coils

Coils are normally of open header box construction (but may have split end covers supplied to order) are completely self-supporting and designed to be fitted directly between or within the sections of the air handling unit.

When split cover plates are supplied these should be removed prior to connections being made, then replaced. Great care should be taken when tightening connections to avoid damage to the coil. The space between the pipe work and cover plates should be sealed with a grommet or similar.

A correctly sized thermostatic expansion valve with external equalising connection must be fitted.

Run the liquid refrigerant line to the TEV which should be fitted to the liquid distributor, feeding the individual circuits of the evaporator coil.

An adequately sized suction line should be run from the suction head to the compressor.

The valve equalising line should be run to the suction line on the compressor side of the valve sensitive phial which should be placed on top of the suction line periphery and secured with a special slip.

A suction liquid heat exchanger should be used to improve the performance of the expansion valve and utilise the complete coil surface.

If your unit is built to HTM standard each coil will come with a removable drain tray. A screw connection joins the tray to the drain line, which can be detached so the tray can be removed and washed down.

A correctly sized sloping drain line with a cleanable "U" bend water trap terminating at an open drain or tundish should be run from each drain connection.

### Hot Water Heating Coils

Coils are normally of open header box construction (but may have split end covers supplied to order) are completely self-supporting and designed to be fitted directly between or within the sections of the air handling unit.

When split cover plates are supplied these should be removed prior to connections being made, then replaced. Great care should be taken when tightening connections to avoid damage to the coil. The space between the pipe work and cover plates should be sealed with a grommet or similar.

A correctly sized sloping drain line with a cleanable “U” bend water trap terminating at an open drain or tundish should be run from each drain connection.

Heater coil automatic control valves should be wired into the fan starter circuit so that valve motors close when fan is stopped. This prevents temperature build up within the unit and possible harm to motor windings, particularly important with high pressure hot water or steam coils.

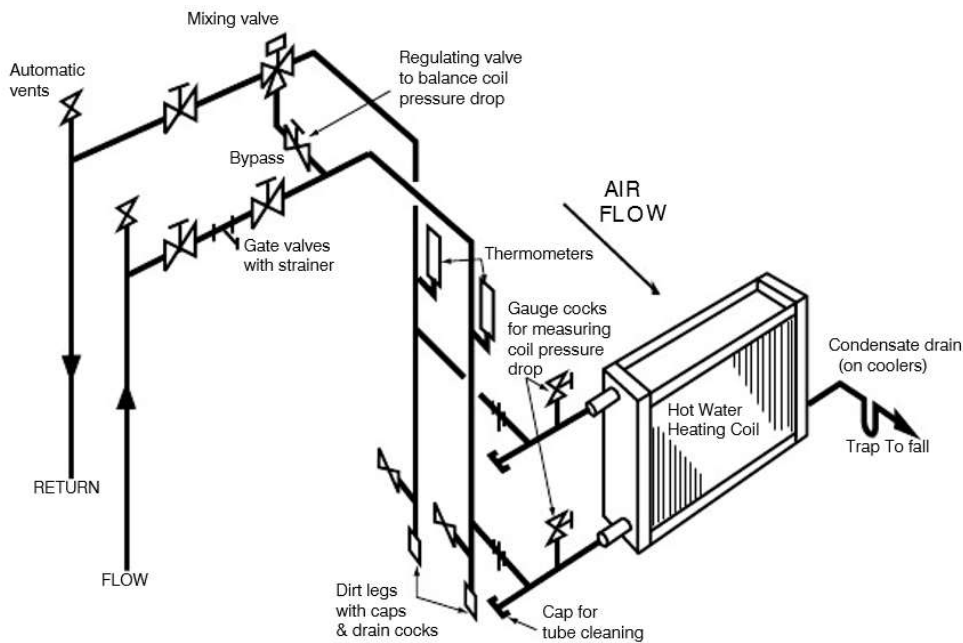

A typical piping arrangement for hot water heating coil

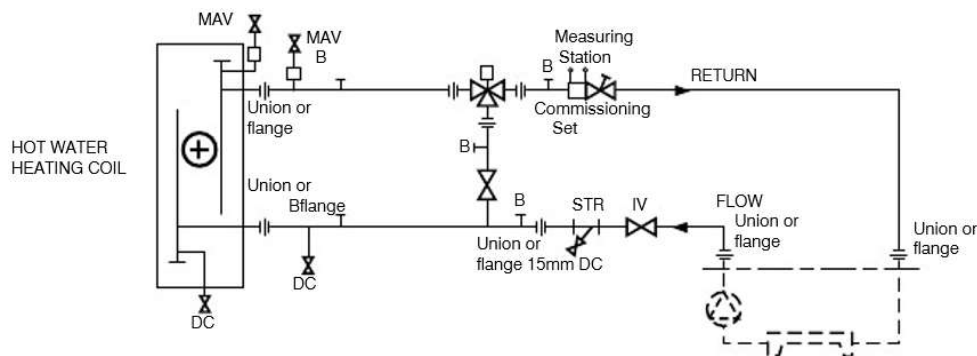

A typical schematic for hot water heating coil

### Steam Coils

Coils are normally of open header box construction (but may have split end covers supplied to order) are self-supporting and designed to be fitted directly between or within the sections of the air handling unit.

When split cover plates are supplied these should be removed prior to connections being made, then replaced. The space between the pipe work and cover plates should be sealed with a grommet or similar.

Check:

- Supply is under 100 PSIG dry.
- Supply is free of air and connected to the top coil connection.
- Connecting pipe work is not supported by coil.
- Expansion allowance made for coil tubes.
- Connections are free from stress and are properly pitched and drained (to avoid water hammer).
- Condensate connections to the steam trap are the same size as the coil outlet.
- Condensate in the main is independently trapped on a coil bypass.
- The steam trap is sized on 3 times the design flow.
- Float or bucket type traps should be carefully selected to suit the steam pressures and temperatures with thermostatic air relief traps on low pressure systems and continuous venting petcocks on medium and high pressure systems.
- Multiple or banks of coils must be individually trapped to meet the demands of the varying capacities and pressures on each section.
- Selection of control valves must be based on the steam load and not the size of the steam coil supply connection.
- Automatic steam control valves are suitable where the condensate is returned to atmospheric pressure or under vacuum.
- They are not recommended on systems where pressure is maintained on the return lines.
- Steam pressure in the coil is not used for lifting condensate.
- If coil is near filter ensure fan runs on after steam supply is cut off (2 minutes).

Note:

- Over tightening connections damages coils.
- Initial rapid heat build-up causes damage to coils and associated pipe work, valve opening must be gradual.
- Check for leaks on initial start-up and after a short period of operation.

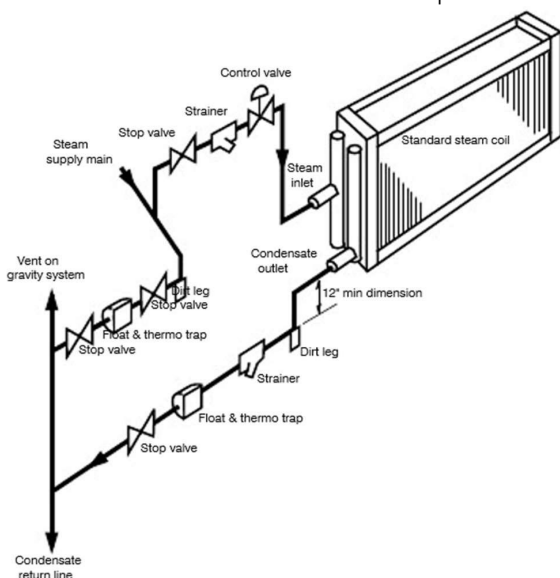

A typical piping arrangement for low pressure steam or vacuum system

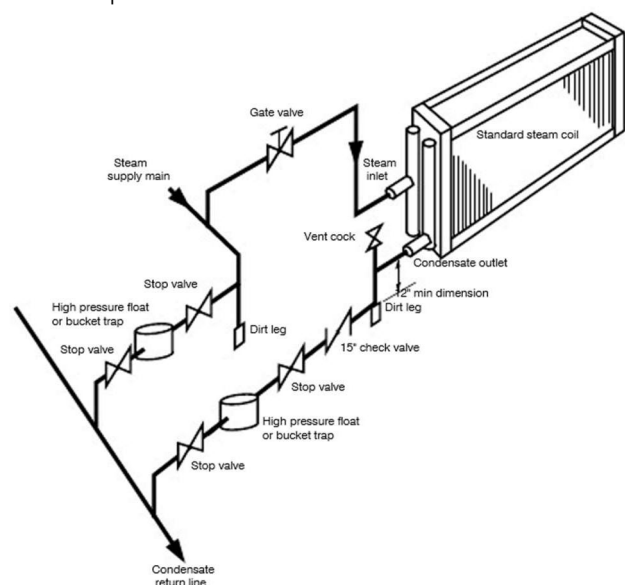

A typical piping arrangement for high pressure steam system

### Electric Heater Batteries

*“If not properly installed and controlled EAHB's are dangerous. They can cause serious injury or death and start fires. Ask your local electricity board fire officer and engineers department to inspect your installation before use”*

Access is by the access door clamped on the side of the unit. Cable entry should be made by drilling a suitable hole in the folded angle corner posts. Screwed glands with cable holding devices should be used at all drilled holes. Do not use P.V.C. cable inside the unit.

Generally elements are intended for phase to neutral connection balanced across 415/3/50 supply e.g. 3 elements phase to neutral stage. Before connecting out of balance loads consult with your local electricity board.

All wiring must be to I.E.E. regulations and conform to all local and national statutory requirements.

A high temperature S.P.D.T. cut out which opens at 165C is fitted, and must be wired in line with the coil of the main EAHB contact breaker. Should this cut out operate, the cause must be ascertained before the hand reset is pushed back in, since the elements may rise to 600C in still air causing filter damage, motor burn out and fire damper link failure etc. etc.

An airflow switch rated at the correct minimum velocity must be fitted (a filter pressure differential switch is NOT suitable).

Fan interlock with the EAHB and fan overrun (of up to 10 minutes after heater battery off depending on EAHB bank size) must be fitted together with automatic recycle to zero load on step controller.

Always ISOLATE the supply before removal of access door and REPLACE the access door before reconnection of supply.

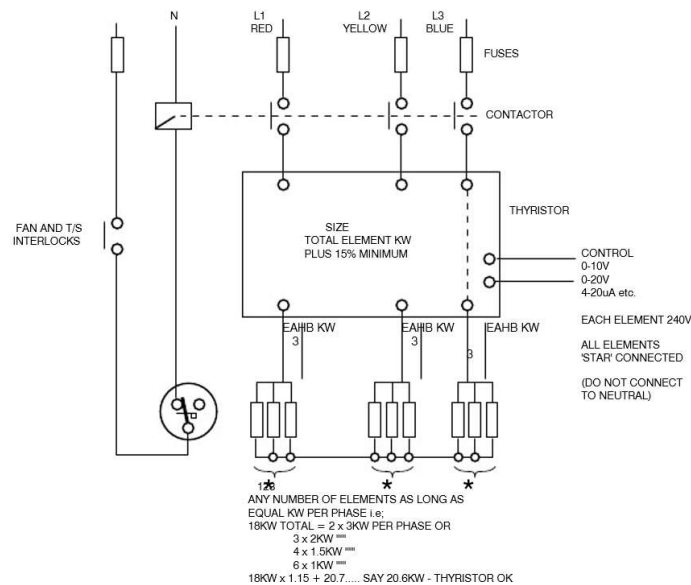

The element tray must be earthed.

Typical schematic for electric heater battery

---

## Gas Fired Heaters

### Safety Notes:

- Commissioning is recommended by our operatives, in any event gas piping, flue, electricity supply and controls should comply with gas safety, gas region, local authority, fire authority and insurance company regulations.
- Do not locate in presence of chlorinated or corrosive vapours, in areas of high risk i.e. cellulose spraying, near combustible materials or where atmospheric depression i.e. an area with extract fan or system, could cause gas reverse flow into area.
- Ensure 24" minimum clearance all round this section.
- Do not obstruct or modify build in diverter.
- Except for servicing never switch off the power supply to the unit.

### Internal Safety controls comprise:

- Main gas valve closure if pilot light out
- Fan on delay unit burner warm.
- Gas off on overheat.
- Fan off delay until burner cool.

### External services required:

- Natural gas supply
- Combustion air supply
- Combustion gas flue
- Electricity supply for controls
- Electricity supply for motive power

### Flue gas discharge:

- Flue gas leaving the top spigot at 260deg C should be vented to atmosphere using a gas board approved flue terminal via a properly sized, individual, VERTICAL, natural draught flue rising 1.8m min.
- Unavoidable horizontal runs (max 3m) should slope 65mm in 300mm and have final verticals riser of 1.5 times the horizontal run. If these conditions cannot be met then factory installed fan assistance should be considered. If condensation is possible it should be avoided by using double skinned flue with special joiner and spigot (consult your local G.A.). If condensation still occurs a non-corrosive 22mm (min) drain should be fitted.

### External controls required are:

- On/off switching (time clock start/stop, thermostat controlling burner)
- Normal electrical controls (fan motor starter, contactors and overload isolators etc.)

### Wiring:

- Refer to appropriate diagram supplied with unit and not the following:
- Switching must be by individual 24V controls to each unit and should incorporate a 24V thermostat, switch and time clock in series.
- Never apply higher voltages (240V supply to motor of time clock must be separate).
- Power into the control box can only be 220V I phase 50c/s.
- Single phase fan motors up to 0.5kw (0.7 h.p.) can be connected via thermal overloads direct to the box.
- Over 0.5kW single phase and all 3 phase motors must have separate electrical supplies controlled from the box via a 240V contactor relay and should be protected by thermal overloads. Inspection prior to initial start up

Gas shut off valve closed:-

- Check all electrical functions - fan motors, room thermostat and gas control set/automatic gas safety system.
- Check correct rotation of fans.

Gas shut off valve open:-

- Carefully vent and check all gas lines for leakage by soapy water testing.
- Close gas shut off valve.

Initial start up

- Switch on main switch
- Supply air discharge(s) open
- Room thermostat "off" lowest setting
- Time switch at "on" period
- Turn on main gas
- The unit will now start
- Refer to user manual supplied with gas heater unit for details start up procedure.

## Electronic Steam Humidifiers

Humidifiers supplied for use with ECE units are electrode boilers which operate at atmospheric pressure and utilise standard water supplies provided the local regulations regarding connection of this type of equipment are observed. If local regulations call for the use of a break tank to feed the unit, the speed at which the humidifier cylinder fills will be determined by the head pressure available. The size of tank, its height and the size of its connecting pipe work must be chosen carefully to ensure the unit always receives an adequate water supply. A built in flow regulator compensates for pressure fluctuations.

### Water - drain connections

- Standard unit inlets are supplied with 15mm brass compression fittings.
- Drains are brass couplings of 1.5" BSP male thread and 1.25" BSP female thread sizes.

### Power Supply

- Connect using conduit entry glands through appropriate knockouts in casing.
- Wiring should comply with the relevant local regulations using appropriately sized circuit breakers.

### Control connection

- When step control or modulation is required, the boiler, services and controls are mounted in a cabinet which may be fixed to the side of the air conditioning unit or to an adjacent vertical surface **BELOW** the sparge pipe level.
- When on-off switching only is required the boiler and its services may be mounted inside the air conditioning unit with the control panel remote.

### Start up

- Close electrical panel
- Turn on water supply to humidifier
- Close circuit breaker feeding power supply to humidifier
- Put run/drain switch into the "RUN" position
- Put on/off switch into the "ON" position
- Humidifier will now operate to the demands of the control circuit.

### Operation of typical electronic steam humidifier

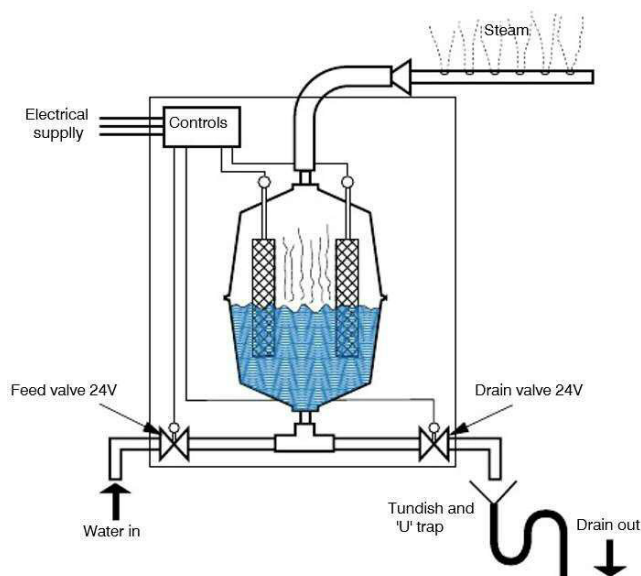



---

## Copra Commissioning

Check and ensure the following before performing commissioning:

- All mechanical and electrical protective devices must be attached and connected.
- Secure touch protection as per DIN EN ISO 13857 based on the installation conditions.
- Design guards in such a way that no falling objects are drawn in by the fan (DIN EN 60529).
- Check the duct system and fan for foreign objects (tools, small parts, construction waste, etc.) and remove where appropriate.
- Check that impeller is free by turning it manually.
- Check the current type, voltage and frequency of the mains connection to ensure that it matches the type plate of the fan or motor.
- Check that connected elements are working properly.
- Close off any inspection openings (insofar as present).

**⚠ WARNING**

*Only when all guards have been attached and the impeller has been secured as per DIN EN ISO 13857 may the fan be started up. The suitability of the protective devices and their fixtures to the fan must be assessed within the overall safety concept of the installation.*

**NOTICE**

*The entire system must be assessed in the concrete application to ensure compliance with applicable standards and directives with regard to EMC. This is the responsibility of the customer.*

## Test Run

Switch on the fan for a short time and check the direction of rotation of the impeller by comparing the rotary direction arrow on the fan.

**⚠ CAUTION**

*Risk of injury from rotating impeller. Wait for the impeller to come to a standstill.*

## Check The Power Consumption

**NOTICE**

*Once the operating speed of the fan has been reached, immediately measure the current consumption and compare it with the nominal current stated on the motor or fan type plate. If overcurrent persists, shut down the device immediately.*

## Check For Smooth Running

**NOTICE**

*Check that fan runs smoothly. If unusual oscillations, vibrations, temperatures and bearing noises are determined, the device must be shut down immediately. The impeller must not drag against the inlet nozzle (audible test) under operating conditions. If it continues to drag, shut down the fan immediately.*

## Volume flow measurement device

The fans are equipped with a volume flow measurement device as standard. This facilitates easy volume flow determination and monitoring of the fan when installed.

$$q_v = K \times \sqrt{\frac{2}{\rho} \times \Delta p_{D\ddot{u}}}$$

$q_v$  Volume flow m<sup>3</sup>/h  
 $K$  Calibration factor m<sup>2</sup> s/h  
 $\rho$  Gas density kg/m<sup>3</sup>  
 $\Delta p_{D\ddot{u}}$  Differential pressure nozzle Pa

For fans that are fitted in a chamber, the pressure difference between static pressure in the suction side chamber and the pressure at the inlet nozzle should be measured. It is important to ensure that the static pressure (measured upstream of the inlet nozzle) is not distorted by dynamic pressure effects. If the differential pressure is routed via a pressure sensor, the signal can also be used for purposes. In order to calculate the volume flow, a calibration factor  $K$  is required for the respective fan. This is determined by a comparison measurement on a standard test rig with unimpaired inflow.

COPRA P/C Size	Calibration factor K10	COPRA P/C Size	Calibration factor K10
250	73	450	156
280	79	500	190
315	89	560	242
355	106	630	310
400	128	710	385
Calib. factor deviation: Standard calibration factor K10 < 10%			

If the simplified formula  $q_v = K \times (\Delta p)^{0.5}$  excl. gas density ( $\rho$ ) shall be used instead, the  $K$ -factor needs to be multiplied with  $(2/\rho)^{0.5}$ , e.g. 1,291 for gas density  $\rho = 1,2 \text{ kg/m}^3$ . When installing the measuring hose, it is important to ensure that the hose is well secured and cannot rub against the impeller. Furthermore, it is important to ensure that the hose is not excessively crushed or kinked.

**NOTICE**

*Certain parameters are required for commissioning. These are factory presets. Incorrect parameters can lead to problems, particularly during start-up.*

## Operating Modes

The speed can be set by analogue control signal (0-10 V, 4-20 mA), PWM or by Modbus RTU. The control behaviour of the individual interfaces is explained in the following sections.

---

## Analogue Control (analogue input signal)

### 0-10 V

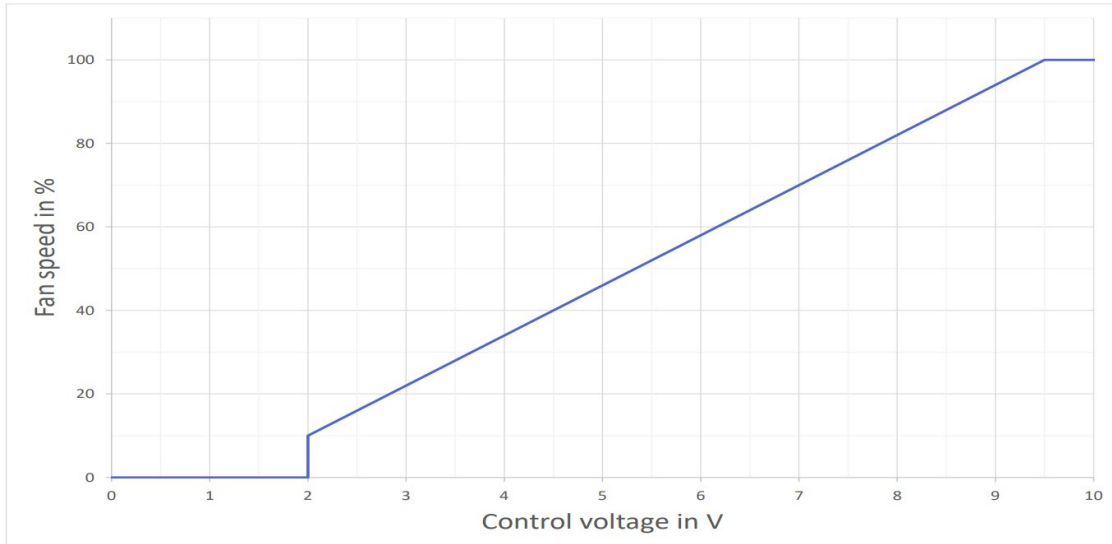

### 4-20 mA

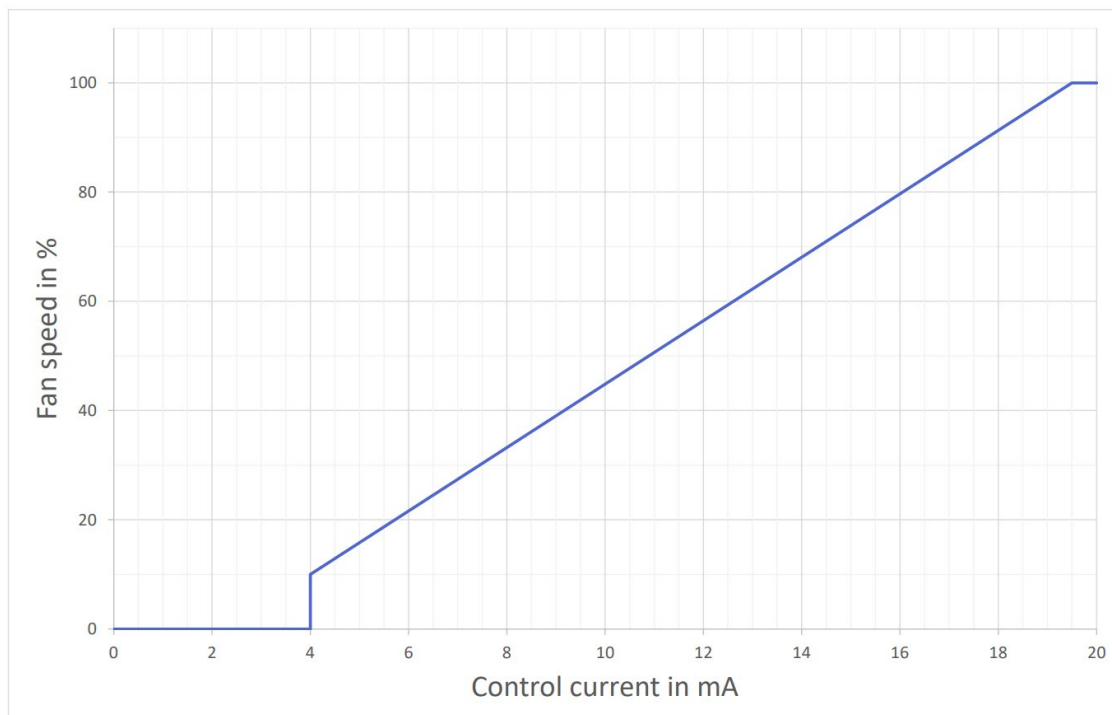

---

## PWM (PWM input)

Another method of setting the fan speed is with PWM input. Pin [PWM] accepts a PWM signal at a frequency anywhere between 50Hz and 1kHz. The duty cycle of the PWM frequency determines the fan speed, with the minimum duty cycle of 5% corresponding with minimum demand and increasing linearly to 100% demand at >95% duty cycle.

Duty Cycle (%) =  $\frac{\text{Turn on Time}}{\text{Turn on Time} + \text{Turn off time}} \times 100$

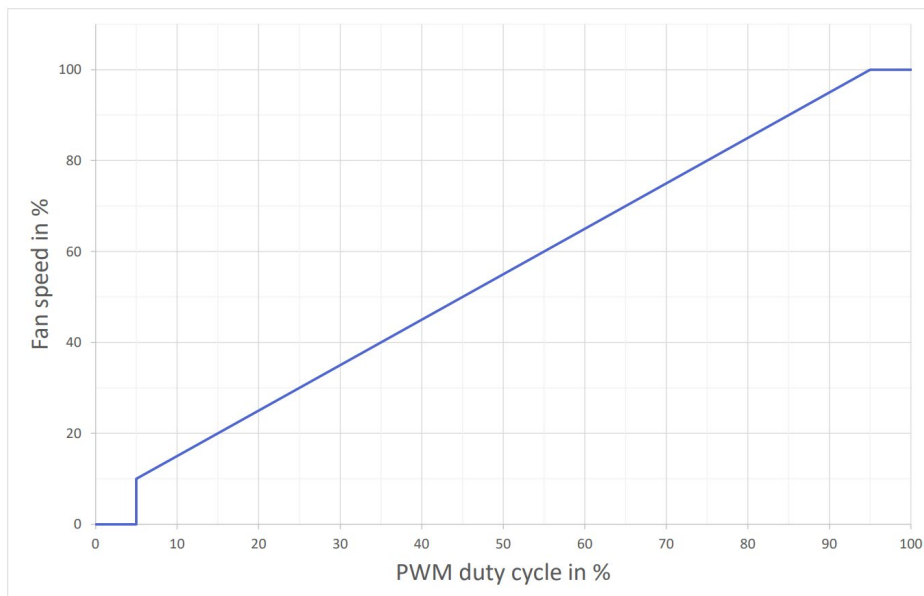

---

## Modbus operation

The Modbus interface has the following default communication settings:

- Protocol: Modbus RTU (8 bit data)
- Address/ID: 247
- Baud rate: 115200
- Stop bits: 1
- Parity: none
- Minimum response time: 50 ms
- Response timeout: >500 ms

The Modbus interface can be used for the following purposes:

1. Adjustment of:
  - Modbus communication settings and monitoring (timeout)
  - Settings/functions of digital/analogue inputs/outputs, -min./max. speed, ramp times, frequency blanking etc.
2. Control:
  - Enable/disable, presetting of speed
3. Monitoring:
  - Query of operating data, such as actual speed, power, fault messages, actual state of digital/analogue inputs/outputs

A complete list of read only and read/write parameters are identified in the COPRA Products Modbus Spec.

## Self Protective Function of The Electronics (faults and motor protections)

COPRATM Fans have two layers of motor protections: UL safety features, and non-UL safety features. The UL safety features are backup protections if the non UL safety faults fails to shuts down or activate limits/derating. If UL safety faults exceed four counts, the safety-core firmware will automatically perform a microcontroller reset.

Non UL Safety/application level protections:

- Over Voltage
- Under Voltage
- Over Temperature
- Loss of Input Phase

UL Safety-core level protections:

- Locked Rotor
- Loss of Output Phase
- Over Load
- Hardware Faults

### Non UL - Over Voltage

1. Drive shuts down on over voltage when DC bus voltage exceeds the threshold voltage (see table below)

1. Model	2. Over Voltage Threshold (DC)	3. Approximate AC Input Voltage
4. 230 V	5. 450 V DC	6. 318 V AC
7. 460 V	8. 830 V DC (1.3 Kw)	9. 586 V AC
10. 460 V	11. 850 V DC (4.5 Kw – 8 Kw)	12. 600 V AC

2. Drive will try to restart after a delay of 2 seconds. If the over voltage condition persists, drive will shut down and indicate an over voltage fault and keeps retrying after the fault wait delay expires. Note that the number of retries is not limited.

### Non UL - Under Voltage

1. Drive shuts down on under voltage when DC bus voltage falls below the threshold voltage (see table below)

1. Model	2. Under Voltage Threshold (DC)	3. Approximate AC Input Voltage
4. 230 V	5. 220 V DC	6. 155 V AC
7. 460 V	8. 440 V DC	9. 311 V AC

2. Drive will try to restart after a delay of 2 seconds. If the under-voltage condition persists, drive will shut down and indicates an under-voltage fault. Drive will keep retrying after the fault wait delay expires. Note that the number of retries is not limited.

### Non UL - Over Temperature

1. Drive shuts down on Over Temperature when IPM temperature exceeds the internal threshold.
2. Drive will try to restart after a delay of 30 seconds. If the over temperature condition persists, drive will shut down and indicates an over temperature fault. Drive will keep retrying after the fault wait delay expires. Note that the number of retries is not limited.

### Non UL - Over Temperature

1. Drive shuts down on Over Temperature when IPM temperature exceeds the internal threshold.
2. Drive will try to restart after a delay of 30 seconds. If the over temperature condition persists, drive will shut down and indicates an over temperature fault. Drive will keep retrying after the fault wait delay expires. Note that the number of retries is not limited.

---

## Non UL - Utility supply power input phase

1. Drive shuts down when loss of input phases is detected and significant power (>50% of rated power) is used.
2. Drive will try to restart after a delay of 30 seconds. If the loss of phase persists, drive will shut down and indicates a loss of phase fault and keeps retrying after the fault wait delay expires. Note that the number of retries is not limited.

## UL - Locked Rotor

1. Drive shuts down on locked rotor on start-up if the locked rotor condition is detected.
2. Drive will try to restart after a delay of 30 seconds. If the locked rotor condition persists, drive will shut down and indicates an UL Locked Rotor Fault and keeps retrying after the fault wait delay expires. Note that the number of retries is not limited.

## UL - Loss of Motor Phase

1. Drive shuts down if a sudden loss of one of the motor phases is detected while the motor is running.
2. This fault is not detected when the drive's output current is zero (when motor is in idle state).
3. Drive will try to restart after a delay of 30 seconds. If the loss of motor phase condition persists, drive will shut down and indicates an UL Loss of Motor Phase Fault and keeps retrying after the fault wait delay expires. Note that the number of retries is not limited.

## Non UL - Derating

- There are three types of deratings:
  1. Current Derating,
  2. Power Derating,
  3. Temperature Derating
- Each of these has the following settings:
  1. Threshold – Derate threshold,
  2. Hysteresis – Threshold below which derate will stop,
  3. Derate period – Wait period before next RPM reduction,
  4. Derate RPM – Amount of RPM to reduce.
- If the measured value exceeds the threshold, the speed will be dropped periodically to keep the measured value until it is below the hysteresis threshold
- Typical temperature threshold is 110 deg C for 1.3kW and 107 deg C for 4.5 kW and 8 kW.

---

## UL - Over Load

- If the measured phase current into the motor is above the UL over load threshold, motor will shut down on Over Load fault.
- Drive will try to restart after a delay of 30 seconds. If the condition persists, drive will shut down and indicates an UL Fault and keeps retrying after the fault wait delay expires. Note that the number of retries is not limited.

## UL - Hardware Faults

1. Drive shuts down on hardware faults if a hardware fault is detected by safety core.
2. Drive will try to restart after a delay of 30 seconds. If the condition persists, drive will shut down and indicates an UL Fault and keeps retrying after the fault wait delay expires. Note that the number of retries is not limited.

**NOTICE**

*After 4 total UL Faults within a power cycle, motor will not attempt restart until after 120 seconds.*



---

## RLM Commissioning

### Safety Checks

- It is to be checked whether all mechanical and electrical safety devices have been fitted and connected.
- Protection devices have to be fitted in accordance with DIN EN ISO 13857!
- The ducts and the fan must be checked for foreign bodies (tools, small components, building debris, etc.)
- The idle running of the impeller must be checked by hand.
- The power setting, voltage and frequency for the mains connections must be checked against the fan or motor type plate.
- Connected control devices must be checked for functioning.
- Check the parameter settings at the frequency inverters for the PM motors (see 6.6).
- Inspection openings (if they exist) must be closed.



The fan may only be commissioned if all the safety devices have been fitted and if it is ensured that the impeller has been safeguarded according to DIN EN ISO 13857!



The suitability of protection devices and their fixtures to the fan have to be evaluated within the complete security concept of the installation.

When operating with a frequency inverter the system of fan-motor-inverter can generate increased vibrations within certain frequencies or fan rpm-areas. Operation in such an area must absolutely be avoided!



When putting the fan into operation this type of eventually occurring resonance rpm have to be determined and to be blinded out. Matching frequency inverters have to be set and operated according to the instructions given by their manufacturer. Non observance of these instructions may cause a destruction of the fan!

### Test Run

The fan should be switched on briefly to check that the direction of rotation of the impeller agrees with that indicated by the arrow. In the event of the motor running in the wrong direction the poles are to be changed over while observing the electrical safety instructions.

### Checking the current consumption

**CAUTION**

On reaching the operating speed of the fan immediately measure the current consumption and compare it with the nominal current on the motor or fan type plate. In the event of a substantial overcurrent switch off immediately.

### Check for quiet running

**CAUTION**

Check on the quiet running of the fan. There should be no unusual rocking or vibration. Check for untypical bearing noises.

## Flow measuring device

The fans are equipped with a flow measuring device as standard. With the flow measuring device it is possible to measure/monitor the flow easily after the fan is installed.

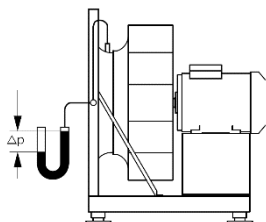

$q_v$  volume flow  $m^3/h$   
 $K$  calibration factor  $m^2s/h$   
 $\rho$  density of media  $kg/m^3$   
 $\Delta p_{Dü}$  pressure difference at cone  $Pa$

$$q_v = K \times \sqrt{\frac{2}{\rho} \times \Delta p_{Dü}}$$

When fans are built in a plenum, it is required to measure the differential pressure between the static pressure in the plenum on the suction side and the pressure at the inlet cone.

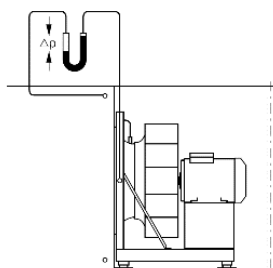

To ensure that the static pressure to be measured at the inlet nozzle is not distorted by dynamic velocities, it is recommended to attach a ring of points on the wall as shown in the following diagram.

When using a differential pressure sensor, the signal can be used for control purpose.

The K- factor is determined by comparative measurement on a standard test ring with non-disturbed air flow at suction.

RLM: (RLC E6) E6-/G6-/E3-	Calibration factor K10	RLM 56-/53-/55-	Calibration factor K10
-	-	2020	58 $m^2s$
-	-	2222	67 $m^2s$
2225 (G6)	73 $m^2s$	2525	77 $m^2s$
2528	79 $m^2s$	2528	73 $m^2s$
2831	94 $m^2s$	2831	90 $m^2s$
3135	106 $m^2s$	3135	105 $m^2s$
3540	128 $m^2s$	3540	120 $m^2s$
4045	155 $m^2s$	4045	150 $m^2s$
4550	190 $m^2s$	4550	190 $m^2s$
5056	242 $m^2s$	5056	240 $m^2s$
5663	310 $m^2s$	5663	300 $m^2s$
6371	385 $m^2s$	6371	385 $m^2s$
7180	490 $m^2s$	7180	485 $m^2s$
8090	628 $m^2s$	8090	620 $m^2s$
9010	794 $m^2s$	9010	790 $m^2s$
1011	1017 $m^2s$	1011	1000 $m^2s$
1112	1280 $m^2s$	1112	1260 $m^2s$
-	-	1214	1540 $m^2s$

---

## Commissioning fans with frequency inverters

### Instructions for fans with PM motors on external frequency inverters

We recommend inverters from the FC-100 range by Danfoss GmbH for operating fans with PM motors without integrated electronics.

In order to operate PM motors without position encoders, the rotors are brought into a defined starting position when starting up. Only then will the motor actually power up.

*Note: Certain parameters are required for commissioning. Incorrect parameters can lead to problems in particular when starting the devices. It is not permitted to operate more than one of the permanent magnet motors with one frequency inverter. Updated parameter lists can be found at [www.nicotra-gebhardt.com](http://www.nicotra-gebhardt.com)*

### Commissioning fans with integrated Danfoss FCP-106 frequency inverters

RLM fans with mounted Danfoss FCP-106 frequency inverters are pre-parameterized for activation via the analogue 0-10V input (terminals 52 (A IN) and 55 (COM A IN)). The enclosed product handbook describes the commissioning of the inverter in detail under "Quick Menu". The start is released by connecting terminals 12 ((+24V OUT) and 18 (DIG IN). If no other protection devices are to be connected to terminals 12 (+24V OUT) and 27 (DIG IN), these terminals must be bypassed.

If terminals 50 (+10V OUT) and 53 (A IN) are bypassed, the fan will run at its maximum speed. If required, a hardware reset can be carried out by temporarily bypassing terminals 12 (+24V OUT) and 19 (DIG IN).

Documentation on the FCP-106 frequency inverters can be found at [www.vlt-drives.danfoss.de/dokumentation/technische-literatur-\(datenbank\)/](http://www.vlt-drives.danfoss.de/dokumentation/technische-literatur-(datenbank)/)

## Commissioning fans with integrated NI-DV inverters

### Connection

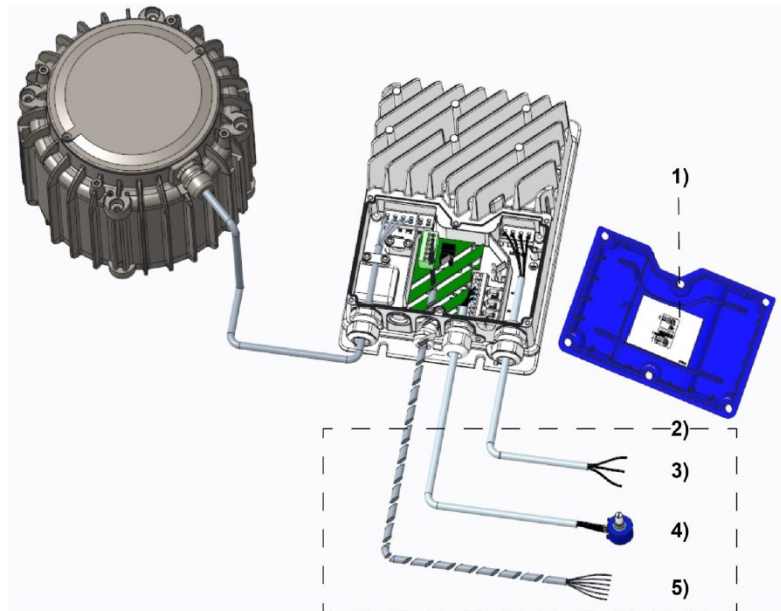

- 1) Circuit diagram
- 2) Connection options provided by the customer
- 3) Mains connection 230V/400V
- 4) Control option 2
- 5) Status output of optional accessories

### Frequency inverter activation options

The control components shown are not available in part as accessories.

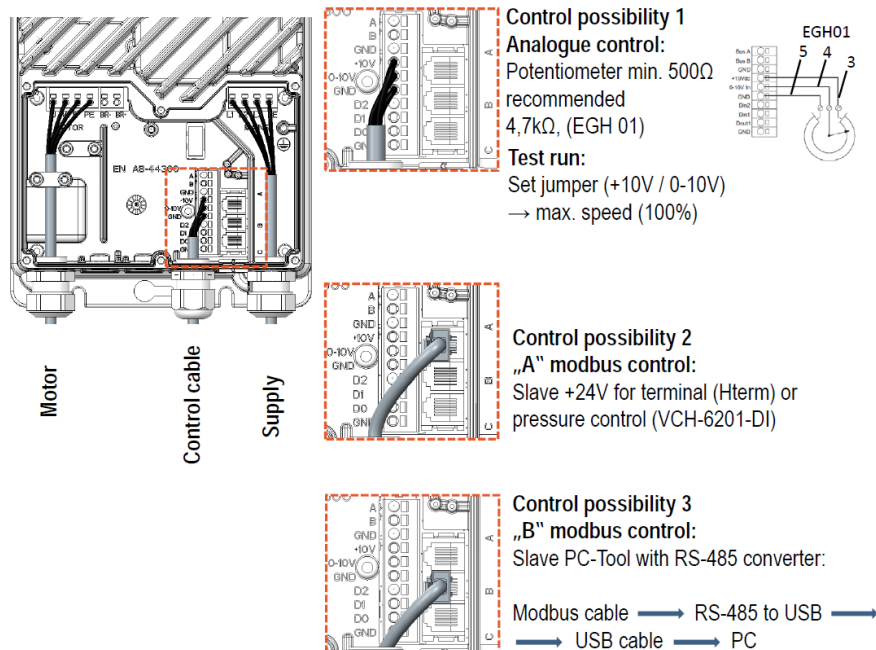

## Maintenance

## Lifting of the Fan Motor

### Lifting Beam

The fan lifting beam hoist consists of a permanent installed extending beam.

Use only a chain which fulfil the requirements of essential health and safety of European machine directive which are CE marked.

The purpose of the lifting beam is to lift the electrical motor or fan out of the air handling unit for replacement or overhaul.

### Working Load Limit

The working load limit of the lifting beam is 300Kg.

### Installation of Lifting Beam is Permanently Mounted

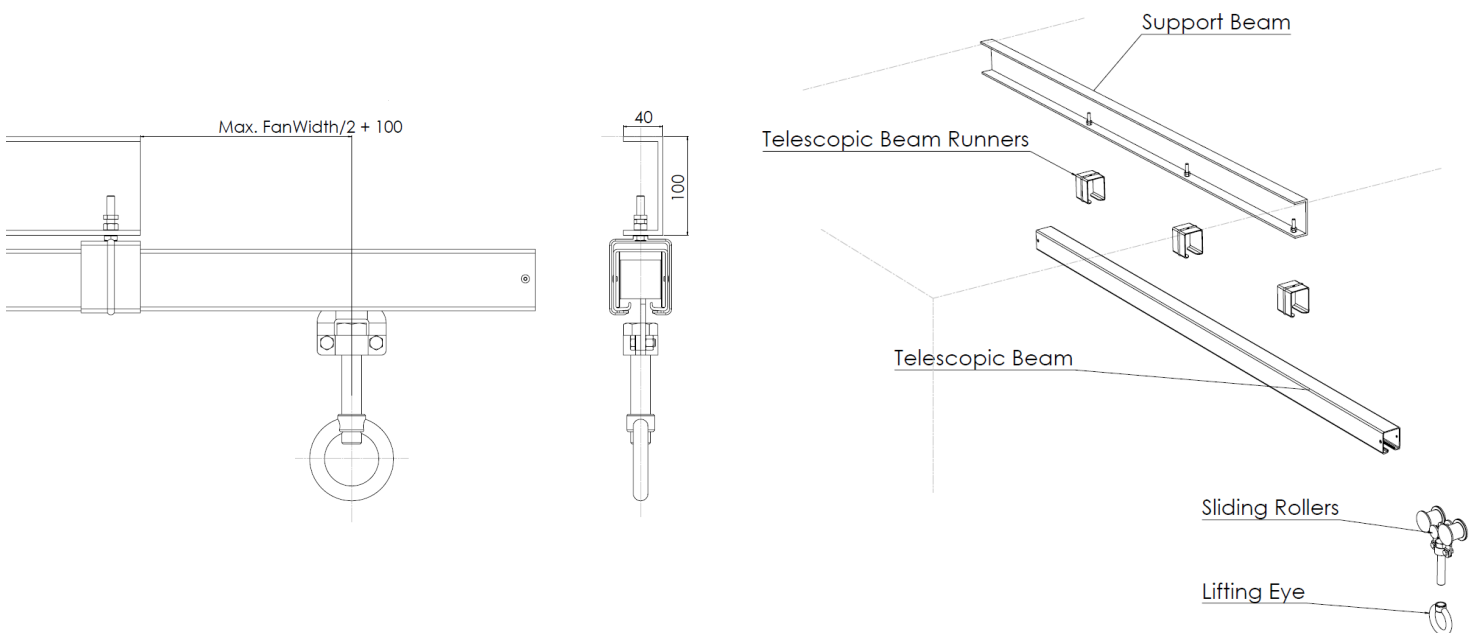

---

## Operation

1. Place a pallet between the air handling unit and the support for transport of the motor.
2. Make sure that the main power is disconnected.
3. Manoeuvre the trolley over the motor and connect the lifting chain hook to the motor lifting points.
4. Free the motor from any mechanical and electrical connection, only qualified personal is allowed to disconnected the electrical power supply.
5. Lift the motor from the motor support.
6. Push the motor in direction of the lifting beam out of the air handling unit.
7. Stop the trolley in the middle of the extension beam.
8. Lower the motor onto the pallet and disconnect the chain hooks.
9. Reassembly takes place in the revered order.

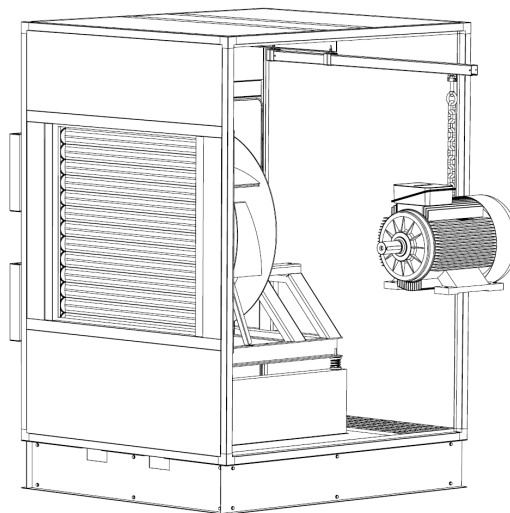

## Checks Prior To Use

Prior to any use of the lifting beam, complete a visual check to make sure that no corrosion has occurred on the screw connection of lifting beam to air handling unit casing. If parts have to be replaced use original parts only by contacting ECE UK Limited.

## Safety Instructions

1. Only personal who have read and understood this manual is allowed to operate the lifting beam.
2. Check the lifting beam equipment according to check prior to use.
3. Never use lifting beam equipment with more than working load limit marked on the equipment.
4. Prior use, follow the third party user manuals of trolley, lever hoist, lifting chain, motor and fan.
5. Do not use the lifting beam equipment for lift of personal, the lifting beam equipment is for lift of electrical fan motor only.
6. Always wear protective gear as e.g. helmet, protective shoes.
7. Work in safety distance to the lifted load and lifting beam equipment.
8. Check with water-level the horizontal position of the lifting beam.
9. Do not have unwatched load hanging on the lifting beam.
10. Two persons are required to install and operated the lifting beam safely.

The lifting beam is for manual operation only

---

## Copra Maintenance and Repairs

### Safety instructions

Before working on the fan, it is imperative to ensure the following:

- All drives have been disconnected from the mains.
- Wait until the impeller has come to a standstill.
- Check the surface temperature to avoid any risk of burns.
- Ensure that the fan cannot start up in an unled manner while performing the maintenance work (for example lockable isolators).
- Observe the regulations of the motor manufacturer and also the inverter manufacturer (where applicable).

**⚠ DANGER** *There is electrical voltage in the intermediate circuit of the electronics and at the main connection when the permanent magnet motor is rotating.*

- Do not perform any work on the fan when the impeller/motor is rotating freely.
- Lock the impeller using suitable means.
- Before performing maintenance work, use suitable means to remove all harmful or hazardous residual materials that have found their way into the fan as a result of the conveying media.

Recommissioning is then performed once the safety inspections stated in Copra Commissioning have been completed. However, work that can only be performed during operation in compliance with the applicable safety and accident prevention regulations is excluded from this. This for example includes measurement of vibrations and shock pulses.

**⚠ WARNING** *Failure to observe these points can present hazards to the life or physical condition of the maintenance personnel.*

**NOTICE** *If the condition of the fan does not allow repair by appropriate means, the fan must be shut down immediately and, if necessary, replaced.*



---

## Maintenance intervals

During extended periods of non-use, the fan should be started up regularly for a short period as a way of avoiding bearing damage due to mechanical stress or ingress of moisture. After being stored for an extended period of time, the motor bearings should both be checked before installation.

**NOTICE** *The maintenance regulations of the motor manufacturer, as well as information from the manufacturers of the switch and devices and the frequency converter must be observed.*

To maintain correct operation and ensure safety, we recommend having the function and condition of fans checked at regular intervals by qualified personnel or a specialist company and having the results documented. The type, scope and maintenance intervals, as well as any further actions that are necessary, should all be specified on the basis of how the fans are used, as well as the conditions in place on site. For the maintenance and inspection recommendations based on VDMA 24186--1, as found on the Nicotra website: [www.nicotra-gebhardt.com](http://www.nicotra-gebhardt.com).

**NOTICE** *Do not use any high-pressure cleaners (steam cleaners). Do not use cleaning agents that contain strong acids or alkalis!*

## Vibrations

The fan should be checked regularly for mechanical vibrations. The maximum vibration velocity in the radial direction on the level of the motor is 4.5 mm/s. In the case of impellers with nominal diameters of up to 315 mm, up to 7.1 mm/s is permitted when fitted. If the permitted vibration values are exceeded, it is mandatory to rebalance the entire rotating unit in accordance with DIN ISO 21940-11.

## Impeller mounting

Following impeller mounting and remounting, the fan must be checked for mechanical vibrations. It may also need to be rebalanced.

## Spare parts

Only use original spare parts as specified in the spare parts list which can be purchased via our online shop [www.aahuk.com](http://www.aahuk.com)

**NOTICE** *We do not accept any liability for damage caused by the use of nonoriginal parts.*

---

## Breakdowns/malfunctions

Deviations from the standard operating conditions of the fan indicate malfunctions and should be investigated promptly by the maintenance personnel.

**⚠ CAUTION** *Malfunctions that persist for an extended period of time can lead to destruction of the fan and also system components, as well as personal injuries.*

If the maintenance personnel are unable to rectify the issue, please request a visit from our aftersales department.

## Recycling and Disposal

The protection of the environment and the conservation of resources are important issues for Nicotra Gebhardt. We therefore pay attention to sustainable, environmentally friendly designs, as well as technical safety and health protection when developing our fans. When disposing of components or waste, please observe the applicable country-specific legal regulations.

## Disassembly

The disassembly of the product must be performed or monitored by specialist personnel. The disassembly process should be prepared as follows:

- Disconnect the machine from the mains and remove all cables.
- Transport the machine to a suitable location for the disassembly process.

**⚠ WARNING** *The products include certain components that are quite heavy. These can fall down during disassembly. This may cause serious physical injury, death and material damage. Secure machine parts that are to be disassembled to prevent them from falling down.*

## Component Disposal and Recycling

The machine is made predominantly from metallic materials. These are fully recyclable. Please separate the components into the following categories:

- Steel and iron, aluminium, non-ferrous metal, insulating materials, cables and leads
- Electronic scrap (where present), plastics
- Electronic components must be disposed of as electronic scrap

---

## RLM Fan Maintenance

### Safety Notes

Before working on the fan it is imperative to ensure:



- All poles of the drives and motors are disconnected from the grid!
- The impeller has come to rest!
- The surface temperature has been checked to prevent burning!
- There is no possibility of an uncontrolled running of the fan during the maintenance work (e.g. through an isolating switch)!

#### **Caution: electric shock!**

There is electrical voltage in the intermediate circuit of the control electronics and the grid connections when the permanent magnet motor turns!



- Do not do any work on the fan while the impeller/motor is rotating freely
- Lock the impeller by suitable means
- Any debris or dangerous materials which have arrived in the fan with the transported medium must be removed using a suitable method.

Fan operation may resume after the safety checks of Section 6 “Commissioning / Safety checks” have been carried out.

Only limited work may be carried out while in the operating condition and in observance of the safety and accident prevention regulations: e.g. measurement of vibration.



Non-observance of these points endangers life and limb for the maintenance personnel.

**CAUTION**

If the state of the fan does not allow adapted action for repair it has to be put out of order immediately and to be replaced if required!

---

## Inspection Intervals

After having passed the period during which the grease keeps its lubrication capacity (30.000 h for standard applications) an bearing exchange may be required. During periods of longer lasting stand stills the fan may be operated shortly in regular intervals. This is to prevent the bearings from mechanical load and the avoid ingress of humidity. If fans have been hold on stock for a longer period the bearings of fan and motor have to be checked prior to installation.

Motors are equipped with permanently lubricated or re greaseable bearings, depending on the manufacturer, size and type of motor. Grease leakage cannot be excluded for motors with re greaseable bearings, even after the initial filling at the factory. However, this does not have a negative effect on the life of the bearings; regreasing intervals must be adhered to.



Ensure that the motor manufacturer's maintenance specifications as well as information provided by the manufacturer for the switches and control units as well as the frequency inverter are observed.

In order to assure a safe operation we recommend to make checks of the fans in regular intervals by specialised service personnel or by a specialised company and to document the result of these checks.

The type, magnitude, and interval period as well as all works which may be necessary in addition depend on the use and the surrounding conditions of the fan and have to be determined case by case.

**CAUTION**

No high pressure cleaners (steam rod cleaners) are to be used!

## Vibrations

The fan has be checked regularly whether vibrations may occur. The maximum vibration speed in radial direction must not exceed 4.5 mm/s to monitored at the bearing or bearing housing of the fan or motor. For fans of a impeller diameter up to 315 mm a vibration speed of up to 7.1 mm/s is acceptable. When exceeding the permitted vibration values, it is mandatory to rebalance the entire rotating unit in accordance with DIN ISO 21940-11.

## Dismantling of the impeller

After dismantling and reinstalling an impeller, the fan must be checked for mechanical vibrations. It may be necessary to rebalance.

---

## Inlet and discharge connections

Flexible sleeving (compensators) between the fan and plant parts are to be checked at regular intervals.

**CAUTION**

Unsealed sleeving leads to breakdowns and danger from escaping transported medium and must be replaced.

## Faults

Deviations from normal operating conditions always lead to functional breakdowns and should be looked for immediately by maintenance personnel.



Longer lasting faults can result in the destruction of the fan and give rise to damage in plant parts and injuries to personnel!

In the event that the maintenance personnel cannot eliminate the fault, please make contact with our mobile customer service.

## Disposal of the product

Used product shall be disposed or recycled according to the local laws and regulations.

## Maintenance Schedule

Item	Interval (in months)					
	1	2	3	4	6	12
SISW / DIDW Fans:						
Fan impeller cleaning				✓		
Fan motor – cooling vents clear, bearings check			✓			
Fan vee-belt drive, wear, tension, alignment		✓				
Plug Fans:						
Check and lubricate the motor						✓
Clean the impeller using a vacuum cleaner, compressed air or by brushing. Greasy dirt can be washed with detergent or a solvent						✓
Filters:						
Filter panels check, clean or renew as necessary	✓					
Filter bag check, clean or renew as necessary:						
➤ Standard			✓			
➤ Fine		✓				
➤ Extra fine		✓				
Filter absolute and activated carbon check, clean or renew as necessary	✓					
Coils:						
Coils venting		✓				
Coils surfaces, connecting piping			✓			
Electric Air Heater Battery:						
EAHBs continuity, earthing, HT cut out			✓			
Wiring, flow switch, fan overrun, controls			✓			
Dampers:						
Bearings, links, free movement			✓			
Motors, bearings, free movement			✓			

Gas Burners						
All points			✓			
Humidifiers:						
Humidifier cylinder electrodes	✓					
Humidifier controls, wiring, piping			✓			
General Maintenance:						
Metal, paint, sealing strips, sealant, fixings				✓		
Insulation, A/Vs, flex, connections, fixings			✓			
Wiring, controls, earth continuity			✓			

\* indicates a one-off activity

This Schedule is not intended to be exclusive, inclusive or mandatory. Different conditions of use may dictate shorter or longer periods and or more intensive action.

## SISW / DIDW - Fan Bearings

### Spider Arm Bearing

Sealed ball races mounted in rubber, pre-greased and self-aligning for service free use under normal duties.

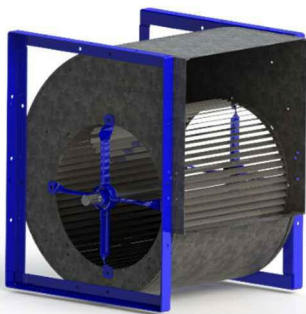
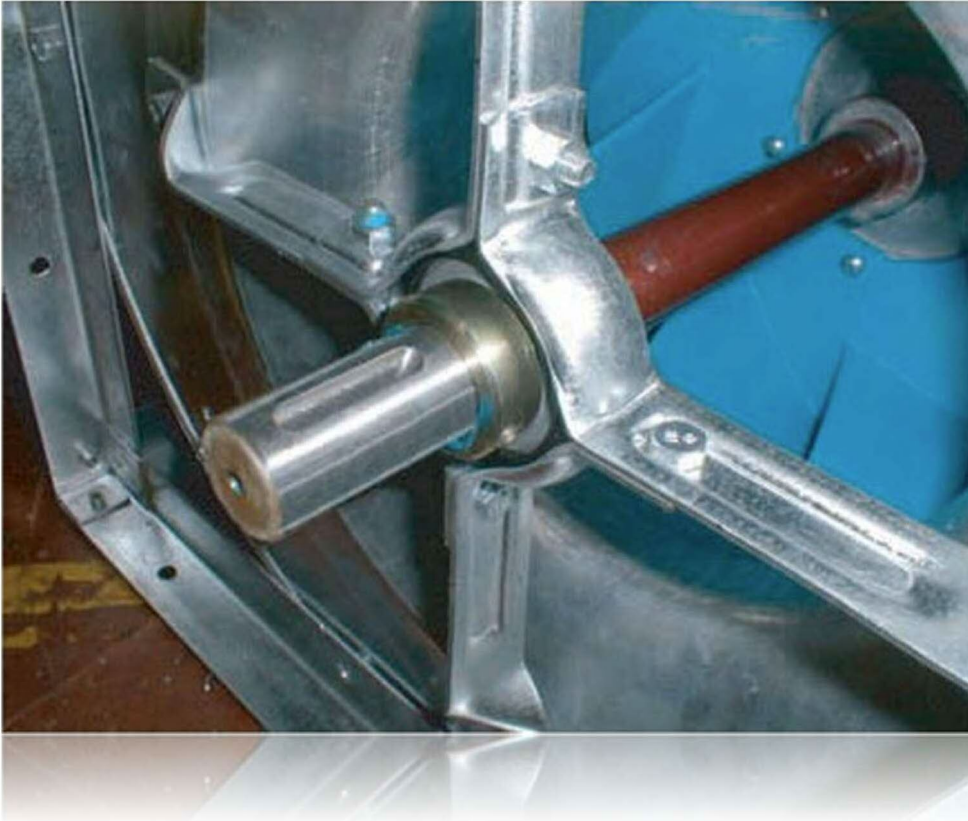

TL3 up to 400 and TL3 450-630

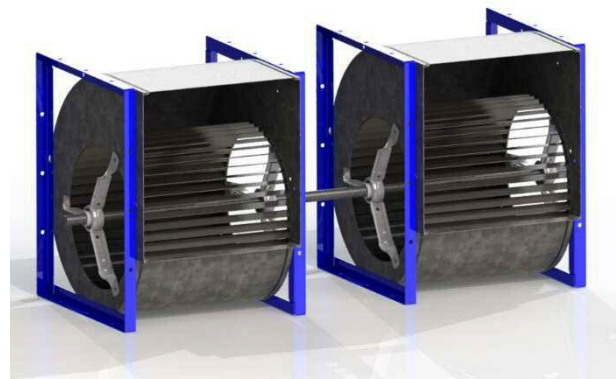

THLZ Duplex – 3 No. spider arm bearings

Units in the ECE range fitted with spider arm bearings



## Plummer Block Bearing

Sealed ball races, mounted in cast iron supports, self-aligning and pre-greased with grease points.



Extended shaft 'A' frame



NTH3 T1 and T2 710 – 1000

Units in the ECE range fitted with Pillow Block bearings

## Replacing the filters (for HTM specification units)



All filters are fitted to universal filter frames. The filters are fixed using C70 clips. To replace a filter:

- Unclip the fastening pins and pivot them in their base



- Once all the clips are loosened the filter will start to come out from the top. Pull the filter out and check neoprene tape for damage, replacing as required

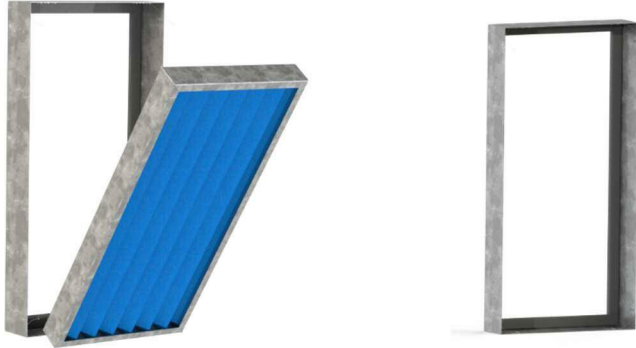

- Push the new filter into the frame, making sure the pleats are all vertical and the filter seals against the neoprene tape

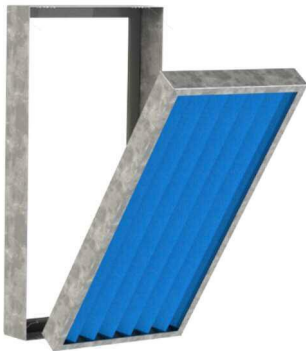

- Re-fasten the C70 pins

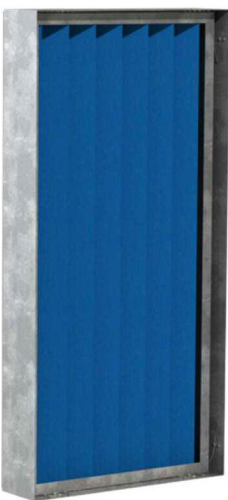

## Motor Bearings

Self-aligning self-oiling and spring loaded ball lubricators, use light machine oil.

Pressure grease fittings and relief plugs, wipe down fitting, remove pressure plug (if fitted) and hardened grease. Add grease till NEW grease is expelled, run motor for 10 minutes, stop motor, clean and replace plus.

The bearing should be repacked with Shell Alvania 2, BP Energygrease 2 or Esso Beacon 2, leaving room for expansion (These greases are suitable for temperatures between -30 C and + 110C).

If a rumble, knock or scrape is heard the motor should be replaced or examined and repaired by an electric motor repair specialist.

NEVER subject the shaft to hard blows, as this may cause damage to the bearings resulting in noisy running and reduce life.

## Motors without Grease Points

Remove belts, run motor and apply the tip of a screwdriver to motor body (not shaft!) and the handle to your ear. A purring sound should be heard. If a squeaking noise is heard the bearing is dry and should be cleaned and flushed, out with a mixture of Tuoline and methylated alcohol (or, in an emergency, white spirit, never petroleum or paraffin).

## Motor Overheating

Check for overheating, ascertain cause and rectify.

## Washable Filters

Wash in mild detergent, rinse and squeeze dry.

## Activated Carbon (Constantly Monitored)

When gas absorption drops below limiting level remove, replace with spare set and sent laden set for reactivation of discard.

## Activated Carbon (disposable non-monitored)

After 1 month usage remove test element or one cell (install new cell) and send for analysis and prediction of remaining life. Replace filters completely within predicted period.

## Electric Heater Batteries

Particularly check condition of wiring and insulation, plus surrounding paintwork/metalwork for signs of overheating.

## Dampers - Motors

Lightly oil damper and motor bearings and link swivels – except nylon bearings.

## Coils - General

Check finned surfaces every six months for build-up of dirt or lint. If required wash down with mild detergent solution and soft brush and blow out any solids between fins with compressed air line. Take care not to disturb the fin surfaces or probe the coils with metal scraper as damage may cause leaks.

At six monthly intervals ensure that the condensate drain lines are unobstructed and functioning.

## DX Cooling Coils

During winter the refrigerant should be pumped over into the liquid receiver and the isolating valve shut. Enough gas should be left in the system to keep a positive pressure in it. Before restarting, the plant should be checked for refrigerant leaks.

## Fault Finding

## Copra Troubleshooting Guide

### Fault Indication – LED Blink Codes

When a fault is indicated, the LED will blink the number of times specified in the chart below followed by a 2 second pause before it blinks again.

Fault	Modbus fault code	LED Code	Description
No Fault	0	0	No Fault
Motor software fault	1	1	Sensor less loop in software lasted too long
Under Voltage	2	2	DC bus voltage falls below the threshold voltage
Over Voltage	4	3	DC bus voltage exceeds the threshold voltage
Over Temperature	8	4	IPM temperature is above threshold.
Speed Feedback	16	5	Measured speed does not match reference speed
Start Up	32	6	Open to close loop transition failed
Loss of input phase	64	7	Disconnection of motor phases
Reserved	128	8	tbd
Hardware Fault	256	9	Hardware over voltage or short circuit fault
UL Safety fault	512	10	One of the UL safety core faults
Internal Communication Loss	1024	11	Internal communication between micro controllers lost
Software Error	2048	12	Motor firmware error

## Centrifugal Fans

Fault	Check
<b>NO AIR FLOW</b> ➤ Fan motor stationery ➤ No current to motor	<ul style="list-style-type: none"> <li>✓ Motor connected</li> <li>✓ Wiring or isolator (on?)</li> <li>✓ Fuses intact</li> <li>✓ Wiring to starter (on?)</li> <li>✓ Starter wired properly</li> <li>✓ Overloads holding in and correct size</li> <li>✓ Wiring to time clock at "on phase"</li> <li>✓ Wiring to panel/mains (on?)</li> <li>✓ Other control circuits holding fan(s) off (eg. gas fired heater warm up)</li> </ul>
<b>NO AIR FLOW</b> ➤ Fan motor running ➤ Current to motor	<ul style="list-style-type: none"> <li>✓ Jammed impeller</li> <li>✓ Seized fan/motor bearings</li> <li>✓ Drive belts too tight</li> <li>✓ Motor windings/wiring faulty</li> <li>✓ Motor wrongly connected</li> <li>✓ Wrong voltage</li> </ul>
<b>NO AIR FLOW</b> ➤ Fan motor running ➤ Fan stationery	<ul style="list-style-type: none"> <li>✓ Jammed impeller</li> <li>✓ Drive belts loose or missing</li> <li>✓ Impeller loose or missing</li> </ul>
<b>NO AIR FLOW</b> ➤ Fan running	<ul style="list-style-type: none"> <li>✓ Louvres blocked</li> <li>✓ VCD's closed</li> <li>✓ Filters blocked</li> <li>✓ Cooling coil frozen solid</li> <li>✓ Duct blocked</li> <li>✓ Fire damper link failed</li> <li>✓ Grilles closed</li> </ul>
<b>LOW AIR FLOW</b>	Check as for no air flow plus:- <ul style="list-style-type: none"> <li>✓ Fan rotation incorrect</li> <li>✓ Filters back to front</li> <li>✓ Media wrong</li> <li>✓ Drive belts slack or greasy</li> <li>✓ Pulley ratios wrong</li> <li>✓ Duct resistance exceeds design</li> <li>✓ Duct leaking on pressure side</li> <li>✓ Access doors off</li> <li>✓ Duct joint not sealed</li> </ul>
<b>HIGH AIR FLOW</b>	<ul style="list-style-type: none"> <li>✓ Low initial clean filter resistance</li> <li>✓ Filter missing</li> <li>✓ Duct incomplete or leaking</li> <li>✓ Pulley ratios wrong</li> <li>✓ Backward bladed impeller installed as forward</li> <li>✓ System resistance over estimated</li> </ul>
<b>MOTOR CURRENT EXCEEDS NAMEPLATE F.L.C.</b>	Check as for no airflow, low air flow, high air flow



### Electric Heaters

Fault	Check
NO HEAT	<ul style="list-style-type: none"> <li>✓ All controls, protective devices and interlocks as described in "Commissioning" section are installed</li> <li>✓ Thermostat setting too low</li> <li>✓ Time clock at "on" phase</li> <li>✓ Filters clean</li> <li>✓ Airflow adequate</li> <li>✓ Isolator connected</li> <li>✓ Mains switch on</li> <li>✓ Power from mains</li> <li>✓ All wiring connected</li> <li>✓ High temperature cut out button in</li> <li>✓ Continuity across H.T. cut out terminals</li> <li>✓ Airflow switch making and breaking</li> <li>✓ Voltage to airflow switch terminals</li> <li>✓ Contactor coil functioning properly</li> <li>✓ Fuses not blown</li> <li>✓ Step controller functioning properly</li> <li>✓ Fan - EAHB interlock functioning properly</li> </ul> <p>If low airflow refer to "Low Airflow" centrifugal fan section.</p> <p style="text-align: center;"><i>If the high temperature cut out has operated do not run system until reason for "cut out" has been found.</i></p>
LOW HEAT	<ul style="list-style-type: none"> <li>✓ Wrong elements supplied</li> <li>✓ Element failure (open circuit or down to earth)</li> <li>✓ Elements disconnected</li> <li>✓ Elements incorrectly wired</li> <li>✓ Wrong voltage</li> <li>✓ Thermostat too low</li> <li>✓ Step controller sticking/faulty</li> <li>✓ Wiring fault</li> <li>✓ Other controller equipment fault</li> </ul>

### Cooling Coils

Fault	Check
NO COOLING ➤ Current to plant	<ul style="list-style-type: none"> <li>✓ Thermostat setting too high/faulty</li> <li>✓ Time clock at "on" phase</li> <li>✓ Motor not connected</li> <li>✓ Overloads tripped</li> <li>✓ (continue checks as for airflow in "fans")</li> </ul>
NO COOLING ➤ HP cut out functioning	<ul style="list-style-type: none"> <li>✓ Correct setting</li> <li>✓ Faulty condenser</li> <li>✓ Heat rejection faulty</li> <li>✓ Fans and pumps stopped</li> <li>✓ Condenser blocked</li> </ul>
LOW OR NO COOLING ➤ LP cut out functioning	<ul style="list-style-type: none"> <li>✓ Suction pressure/evaporating temperature too low</li> <li>✓ Coil freezing up</li> <li>✓ Condenser too large for evaporator</li> <li>✓ Low air flow</li> <li>✓ Uneven air flow</li> <li>✓ Low entering air temperature</li> <li>✓ Humidistat(s) calling for dehumidification</li> </ul>

	<ul style="list-style-type: none"> <li>✓ Low compressor capacity control installed and functioning</li> </ul>
NO COOLING ➤ Chilled water isolating valve closed	<ul style="list-style-type: none"> <li>✓ Thermostatic valves closed</li> <li>✓ Thermostat failure</li> <li>✓ Circulating pump failure</li> </ul>
NO COOLING ➤ LP cutout functioning ➤ Expansion valve freezing	<ul style="list-style-type: none"> <li>✓ Water in system</li> </ul>
LOW COOLING ➤ Fridge plant cycles	<ul style="list-style-type: none"> <li>✓ Low load (unloader) compressor capacity control functioning</li> <li>✓ Step controller functioning</li> <li>✓ Other modulating controls functioning</li> </ul>
HIGH RH	<ul style="list-style-type: none"> <li>✓ Humidistat or dewpoint stat too high / faulty</li> <li>✓ No cooling</li> <li>✓ Coil fault (see above)</li> <li>✓ Entering air temperature too high</li> <li>✓ Insufficient cooling capacity (maybe start up, pull down time)</li> <li>✓ Excessive fresh air or airflow</li> <li>✓ Excessive moisture gain</li> <li>✓ Moisture carryover</li> </ul>
LOW RH	<ul style="list-style-type: none"> <li>✓ Stat too low / faulty</li> <li>✓ Coolant too cold</li> <li>✓ Refrigerant plant capacity too high</li> <li>✓ Inadequate controls</li> <li>✓ Insufficient air flow</li> </ul>
COIL SWEATING	<ul style="list-style-type: none"> <li>✓ Blocked filters</li> <li>✓ Blocked coil face</li> <li>✓ Air on dewpoint condition higher than design</li> <li>✓ Chilled water flow temperature or DX evaporating temperature lower than design</li> </ul>
MOISTURE CARRY OVER FROM FINS (or past eliminators if fitted)	<ul style="list-style-type: none"> <li>✓ Check as for "coil sweating"</li> <li>✓ High volume</li> <li>✓ Uneven face velocity</li> <li>✓ Eliminators omitted in error</li> </ul>
MOISTURE CARRY OVER FROM DRAIN TRAY (or drain tray not emptying or leaking)	<ul style="list-style-type: none"> <li>✓ Horizontal</li> <li>✓ Undamaged</li> <li>✓ Drain tray outlet to U-trap not clogged</li> <li>✓ Primed adequate differential U-trap drain</li> <li>✓ Adequately sized correctly pitched condense line dropping into open tundish</li> <li>✓ Upstream restricted airflow causing depression at coil greater than U bend differential</li> <li>✓ Cover plates leaking air on bolt on coils</li> </ul>

### Heating Coils

Fault	Check
NO HEAT	<ul style="list-style-type: none"> <li>✓ Thermostat too low/faulty</li> <li>✓ Time clock at "on" phase/faulty</li> <li>✓ Pump failure</li> <li>✓ Boiler plant off</li> <li>✓ Automatic valve closed due to thermostat</li> <li>✓ Valve transformer failure</li> <li>✓ Isolating valves closed</li> <li>✓ Airlock</li> </ul>
LOW HEAT	<ul style="list-style-type: none"> <li>✓ Check flow and return temperature - if low check boiler plant and controls</li> <li>✓ Check flow rate – if low check:-</li> <li>✓ Regulating valves open</li> <li>✓ Insufficient pump head</li> <li>✓ Piping sizing wrong</li> <li>✓ Blockage in coil or high coil resistance (check temperature change across coil and equal tube temperatures).</li> <li>✓ Warm up time adequate</li> </ul>

### Refrigeration

Fault	Check
HEAD PRESSURE TOO HIGH	<ul style="list-style-type: none"> <li>✓ Refrigerant overcharge - vent excess charge</li> <li>✓ Air in system - leak test, repair leak, evacuate and recharge</li> <li>✓ Dirty Condenser - clean</li> <li>✓ Malfunction of condenser fan (air cooled) - check head pressure speed control if fitted</li> <li>✓ Restricted water flow - check flow rate and adjust</li> <li>✓ Water on temperature too high - cooling tower operation</li> <li>✓ Blockage in discharge pipe work - check and replace damaged section(s) evacuate and recharge</li> <li>✓ High air temperature entering condenser (air cooled) spill over between adjacent condenser, fit baffle or re-site condensers</li> </ul>
LOW HEAD PRESSURE	<ul style="list-style-type: none"> <li>✓ Refrigerant under charge - leak test, add refrigerant if necessary</li> <li>✓ Over condensing - Fan speed too high (air cooled), water flow too high (water cooled)</li> <li>✓ Faulty valves</li> <li>✓ Low external ambient - pre heat air to cooled condenser</li> <li>✓ Low back pressure</li> </ul>
HIGH BACK PRESSURE	<ul style="list-style-type: none"> <li>✓ Air flow too high – adjust belt drive as necessary</li> <li>✓ Room temperature or air on too high – adjust thermostat</li> <li>✓ Faulty expansion valve</li> <li>✓ Also see– "Head pressure too high" above</li> </ul>
LOW BACK PRESSURE	<ul style="list-style-type: none"> <li>✓ Air flow too low – adjust belt drive as</li> <li>✓ Filters dirty</li> <li>✓ Shortage of refrigerant – leak test add refrigerant as necessary</li> <li>✓ Faulty valves</li> <li>✓ Blockage in pipe check and replace damaged section(s) evaluate and recharge</li> </ul>
SUCTION LINE SWEATING BACK TO COMPRESSOR	Expansion valve open too wide

## Fan Drive Belts

		PROBLEM																
		Loose cover & swell	Weathering or 'Craze' cracks	Gouges	Stalling	Envelope wear	Uneven envelope wear	Ply separation	Side split	Broken belts	Belts turn over	Hardening / premature cracking	Squeal	Excessive stretch	Vibration	Belts too long at installation	Belts too short at installation	Mismatched belts at installation
PROBABLE CAUSES	Excessive oil	●																
	Exposure to elements	●																
	Belt forced over pulley rim		●															
	Contact with obstruction			●														
	Insufficient tension				●									●				
	Stalled driven pulley				●													
	Excessive slip					●												
	Rough pulleys						●											
	Substandard pulleys							●	●									
	Excessive tension									●								
	Shock load										●			●				
	Foreign material										●							
	Excessive dust					●												
	Drive misalignment										●							
	Worn pulley grooves										●			●				●
	Excessive vibration										●							
	High ambient temperature											●						
	Excessive tension													●				
	Drive underbelted													●				
	Damaged tensile member														●			
	Incorrect belts															●	●	
	Incorrect drive set up															●	●	●
	Insufficient take up															●	●	
Improper matching																	●	
Mixed old and new belts																	●	
Non parallel shafts																	●	
Different manufacturers																	●	
REMEDY	Lubricate properly	●			●													
	Clean pulleys & belt(s)	●																
	Replace belt(s)		●											●				●
	Provide protection		●			●				●								
	Install properly			●				●	●					●				
	Check for belt length			●														
	Remove obstruction			●														
	Tension properly				●	●							●	●	●			
	Free pulleys				●													
	Replace pulleys					●				●			●					●
	File smooth						●											
	Redesign drive							●	●									
	Operate properly									●								
	Align drive					●					●							●
	Provide ventilation											●						
	Check for proper belt(s)												●		●	●		
	Check machinery													●	●	●		
	Use only new belts																	●
	Use single source																	●