

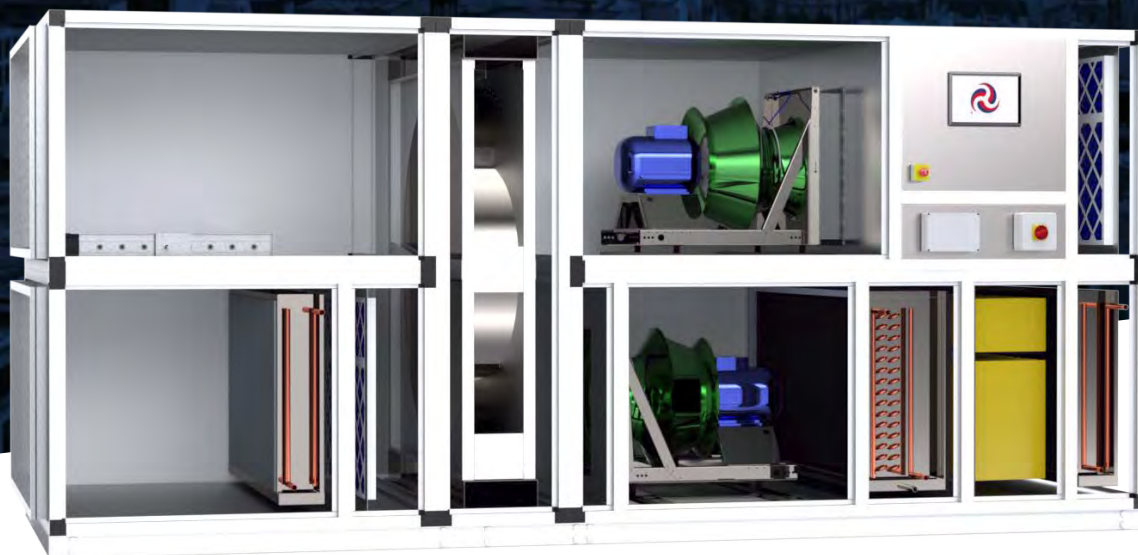

Rotary Exchanger Aluminium 3-Way Mix RXA3MX



Selection Data



Company Profile

ECE UK Ltd is a privately owned company that was established in 1979 by the existing directors and shareholders. We operate from our 4,000m² manufacturing facility in Rochester where we produce air handling / conditioning units and controls of the highest quality; which is reflected by our level of customer retention.

With forty years of experience, we are a leader in the field of air handling, conditioning and control systems.

Our experienced and knowledgeable members of staff have obtained qualifications from HNC to Master's Degree. To compliment this we provide an in-house and external training programme. We are committed to working in partnership with Consultants, Contractors and End-Users, providing added value through technical innovation, service excellence and the ability to provide energy efficient solutions.

ECE UK offers a wide range of Products and Services that complement our RXA3MX range of Air Handling Units including:

Air Conditioning

Heat pump units and interconnecting refrigeration pipe work.

Controls

Trend Control systems either mounted internal to AHU or remote.

Site Wiring

Our qualified engineers would install all interconnecting control wiring external to the air handling unit along agreed routes.

Plant Movement

Refurbishment, Removal, and Installation of Air Handling Units, Air Conditioning Units and Controls.

After Sales

Warranty assistance and troubleshooting of site issues for Air Handling Units, Air Conditioning Units and Control Systems.

Service & Maintenance

Platinum, Gold and Silver maintenance packages for Air Handling Units, Air Conditioning Units and Control Systems.

By providing the many Products and Services in one place we can offer you the convenience of obtaining all your ventilation, air conditioning and control requirements from one manufacturer.



RXA3MX Explained

Heat Recovery Efficiency

Dependent on the right conditions, heat recovery efficiencies can reach 82%. The correct efficiency is a subjective decision and depends on the economic calculation and written guidelines, i.e. Eco-design Commission Regulation (EU) No 1253/2014, on operating data such as energy prices, useful life, running times, temperatures, maintenance costs and interest rates. With regard to (EU) No 1253/2014, profitability and environmental protection the heat recovery efficiency should be no less than 73%.

Operation

Rotary heat exchanger air handlers are configured either in a side-by-side or double stacked configuration. Rotary heat exchangers are classified as regenerators with rotating carrier. In a counter flow arrangement, the rotating, air permeable storage mass is heated and cooled alternately by heat releasing and heat absorbing air streams. Depending on the air conditions and on the surface of the storage mass also moisture may be transferred in this process. The supply and extract air streams must be adjacent and pass through the heat exchanger simultaneously.

From this process the specific heat output capacity depends on the temperature difference between the two air streams. Hence the rotary heat exchanger is suitable for heat as well as cool recovery, i.e. for winter and summer operation.

The AHU air-mixing plenum combines two air streams. The configuration includes three sets of dampers: one for the fresh air, one for the exhaust air, and a mixing damper between the two air streams. The mix of fresh air and recirculated air can thus be adjusted to suit the needs of the building's occupants. Typically as the fresh air and exhaust air dampers are driven from 0% open to 100% open, the mixing damper will in turn be driven from 100% open to 0% open, so as to always ensure a constant volume of supply and extract air.

Intelligent Energy Control

Either our Intelligent Energy Control system or the clients BMS may monitor the return air quality, energy efficiency available to recover or CO₂ concentration for optimum energy efficiency whilst maintaining desired fresh air requirements. Additionally, when outside air conditions are such, typically mid-season weather conditions, it may be that ambient temperatures are suitable for free cooling purposes.



Basic Principles

ECE UK rotary heat exchangers belong to the group regenerative heat exchangers. Rotor movement means that exhaust air and supply air pass the rotor medium alternately.

The ability to recover both thermal (sensible) and humidity (latent) energy makes rotary heat exchangers very efficient.

The rotor matrix is made for laminar airflow using alternating layers of smooth and corrugated foil to provide a structure comprising small, triangular channels. This design allows cleaning with compressed air, steam, hot water or special cleaning agents.

Their operating temperature range is between -20°C and $+70^{\circ}\text{C}$.

Foil Type

Rotary heat exchangers are classified into three different types; condensation rotors, hygroscopic rotors and sorption rotors.

Condensation Rotors, Non-hygroscopic Rotors

The condensation rotor is a cost-effective solution to remove heat and is suitable for standard applications in comfort ventilation. Humidity is only transferred in cases when the dew point of one of the air streams is reached during winter conditions.

Hygroscopic Rotors

The hygroscopic surface of this rotor class supports humidity transfer. Typically used for standard applications in comfort ventilation systems to recover humidity during winter temperature periods.

Sorption Rotor Muonio (HM) and Sorption Hybrid Rotor

The high performance desiccant coatings of the sorption rotor HM (molecular sieve 3\AA) provide a maximum humidity transfer capacity for minimal Carry Over. The high humidity efficiency is constant throughout all climate conditions.

Sorption rotors are especially designed for summer season cooling recovery and dehumidification of supply air. Therewith, it should always be used in humid and hot climates, with dry cooling systems (chilled beams) and when in winter time humidifiers are used. This substantially reduces the cooling and humidification demand of the air handling system.

Drive Equipment

ECE UK provides easy, operationally reliable drive equipment for variable speed operation.

Rotors are driven by a motor mounted on a bracket inside the casing. All rotors are driven by the motor via a belt to the rotor periphery.

All motors are 4-pole with integrated thermo-switches that monitor winding temperatures.

Belt pulley size and/or gearing are dimensioned to achieve optimum rotor rpm.

Variable Drive

Variable drive enables rotor speed regulation and thus optimal control throughout the year.

The drive unit consists of a motor and control unit that regulates motor rpm in relation to an input signal.

MicroMax

Micromax is a standardised, user-friendly control unit with all necessary functions.

Micromax is controlled by 0-10 V input signals.

Rotor speed is proportional to the control unit input signal.

Micromax is connected to 4-pole induction motors with reduction gears or 4-pole asynchronous motors with worm gears. All motors are three-phase versions equipped with thermo-switches.

Double Sealing (SX) and/or Extra Belt (BX)

Double sealing consist of an extra layer of brush sealing on the middle beam and around the rotor periphery. This is recommended in installations with high pressure differentials between the supply and exhaust ducts.



Functional Description

1. Rotor matrix (hub, bearings and foil)
2. Drive equipment (motor, control unit and belt)
3. Casing (structure, purge sector and seals)

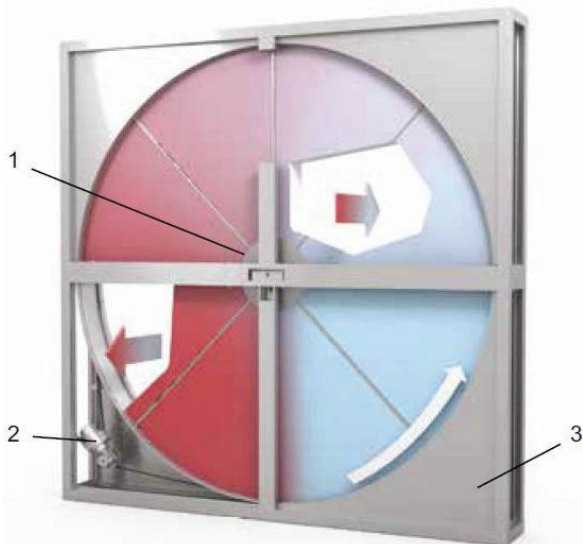

Carry Over

The heat exchanger matrix rotates between two contra-flowing air streams. When the rotor passes the separating floor between the air streams, the air trapped in the matrix is transferred from one duct to the other. This phenomenon is called carry over.

If no action is taken, trapped air will be constantly transferred between the air streams. In this way, a small part of the exhaust air can get mixed with the supply air.

Purge Sector

To prevent exhaust air mixing with supply air by carry over, a purge sector can be installed. Its function is to flush the rotor matrix with outside air before it rotates into the supply air duct. In this way only outside air is present in the matrix and no carry over of exhaust air to supply air is possible.

The purge sector is located on the supply side of the supply air duct. No purge sector is installed on the opposite side, where the matrix leaves the supply air duct, as transfer of outside air to outlet air does not impair supply air quality.

Purge Flow and Effect of Performance

The magnitude of the purge flow depends on rotor diameter, purge sector angle and the pressure differential between supply and exhaust air, and outside and exhaust air respectively.

In theory, purge flow affects technical performance such as temperature efficiency and humidity efficiency only marginally and has no practical significance.

Recommended Installation

The best flow conditions are achieved when supply and exhaust air fans are installed on the suction side of the regenerative heat recovery unit. A reasonable pressure difference between the supply air and exhaust air ducts is obtained in almost all installations.

Alternatively, the outside airflow fan can be located in the direction of flow upstream of the rotor. This variation is often found in hospital installations where the entire supply air section is run at overpressure. The risk of supply air contamination is thus eliminated.

Constant Pressure and Recirculating Air

Blow through exhaust air fans and draw through outside air fans are typical in installations where constant duct pressure is necessary.

The system leads to a negative pressure differential between p22-11 and because a purge sector is unable to function correctly, the purge sector should not be installed. Therefore blow through exhaust air fans should only be used in systems where draw through is not possible.

Project Planning Advice

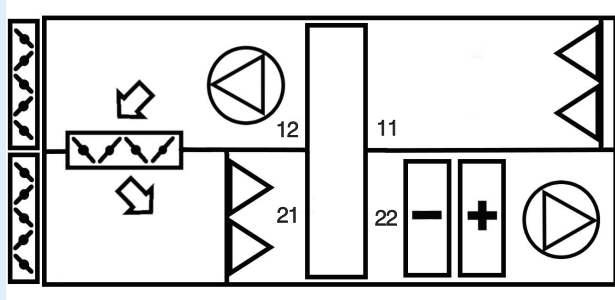

Draw through fan setup

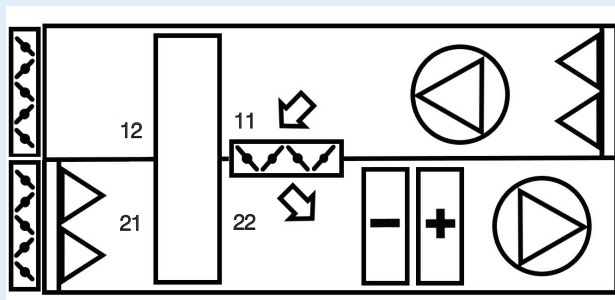

Blow through exhaust fan setup

Materials Selection

Different environments demand different materials. ECE UK offers materials that are suitable for most environments.

Low to normal corrosion risk

Aluzinc coated sheet metal is usually used in areas with low to normal corrosion risk. Frames are made from aluminium. All of our rotor materials are ideally suited for their purposes. All bearings are life-time lubricated and sealed for extended life.



Popular RXA3MX Configurations

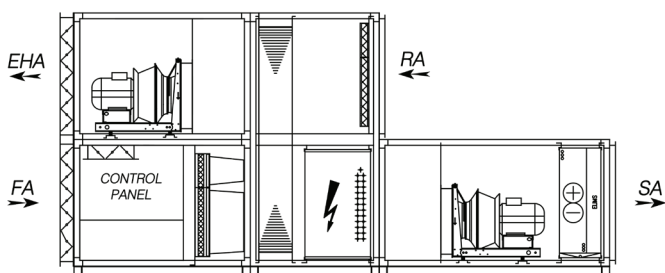
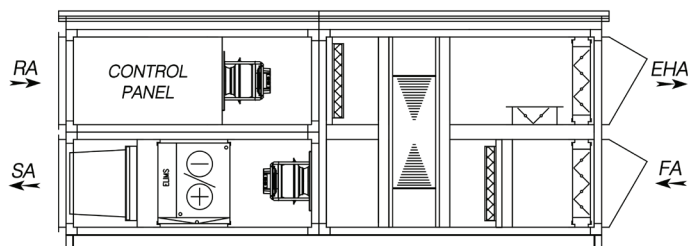
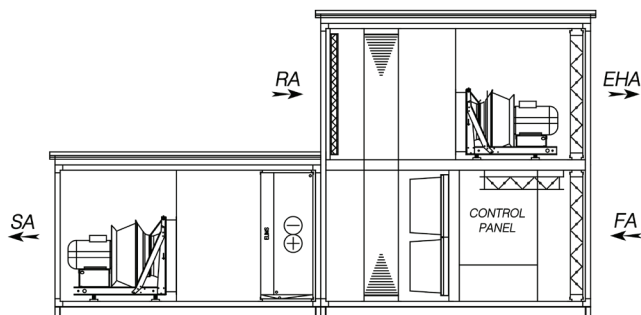
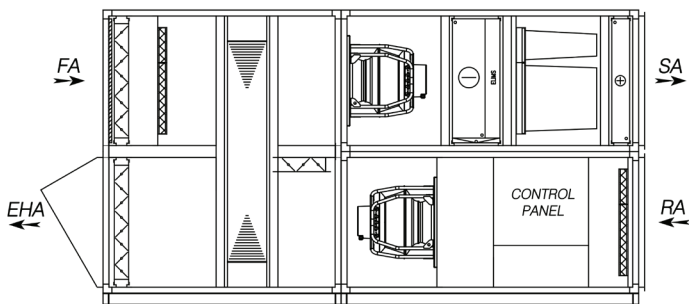
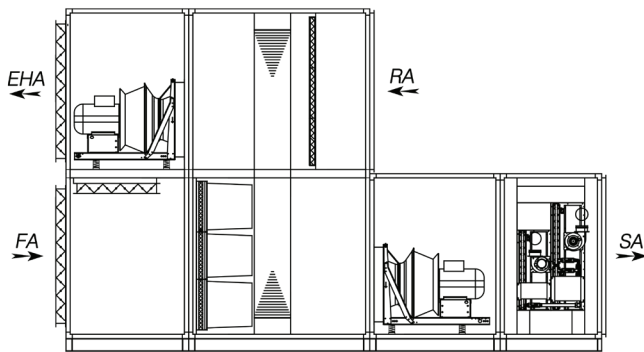

Selection Information

- Dimensions on pages 8 & 9 are for roughing in only.
- To keep specific fan power (SFP) within ERP 2016 and L2 requirements, the following should be adhered to:
 - For AHU's with external system resistance <200Pa for both supply and extract systems, keep the face velocity between 2.5 and 3.0 m/s.
 - For AHU's with external system resistance between 200Pa – 400Pa for both supply and extract systems, keep the face velocity between 2.0 and 2.5 m/s and include 635mm long bag filters.
- Contact technical sales for specials if unit sizes are difficult to accommodate.
- Fan total pressures from 100Pa to 1500Pa (including AHU internal losses).
- Maximum external pressure available i.e. AHU inlet negative pressures plus AHU discharge positive pressure = fan static pressure less AHU internal component resistances for both extract and supply AHU's.
- Height and width dimensions in tables are the AHU frame outside dimensions. Add base dimension, also add roof dimension (RH) if unit is external.
- Component length dimensions are space that each internal component occupies.
- Maximum overall AHU length unlimited. (Maximum single piece size subject to transport restrictions).
- Frame inlet connections generally 30mm up to size 5 and 50mm size 6 and above, around frame perimeter, undrilled.
- Inlet connections can be mezz flanges 30mm and 40mm as required.
- Outlet fan connections from unit – see dimension tables.
- If fresh air intake is at the bottom of the AHU and the supply sits at the top of the AHU the extract section at the bottom of the AHU will need blank plenums to support the supply.
- Individual section lengths including components like coils, attenuators or filters can range from 300mm to 2400mm. Each individual component does not have to sit within its own section.
- It is possible to have up to 4 stages of filtration on both the supply and extract air streams.
- "X" dimension will only be required if the supply or extract fan is downstream of a full face component, other than the plate heat exchanger.
- Due to ERP 2016, level of filtration to always be F7 grade supply and M5 grade on extract.
- Gas heaters should be the last component in supply air configuration.
- Due to height restrictions, floor grid available from unit sizes 6 to 15 only. No need for floor grid if walk in access is not possible.

Velocity Chart

(Vc)m/s	VOLUME m³/s AT COIL FACE VELOCITIES (Vc) m/s	Unit Size													
		1	2	3	4	5	6	7	8	9	10	11	12	13	14
1.75		0.52	0.73	0.97	1.28	1.56	2.00	1.98	2.48	3.27	4.37	5.24	6.39	7.57	9.88
2.0		0.60	0.86	1.13	1.41	1.90	2.36	2.32	2.88	3.80	5.06	6.08	7.60	8.65	11.27
2.25		0.68	0.95	1.26	1.59	2.15	2.65	2.61	3.25	4.28	5.69	6.83	8.55	9.73	12.68
2.5		0.75	1.07	1.40	1.77	2.38	2.94	2.90	3.60	4.76	6.33	7.60	9.50	10.82	14.09
2.75		0.84	1.17	1.54	1.94	2.62	3.23	3.19	3.96	5.23	6.97	8.35	10.45	11.90	15.50
3.0		0.91	1.28	1.69	2.12	2.86	3.53	3.48	4.32	5.71	7.60	9.12	11.40	12.98	16.91
3.25		0.97	1.39	1.83	2.30	3.10	3.83	3.78	4.69	6.19	8.24	9.88	12.35	14.06	18.32

*Please select unit size from the above table using the velocity first, then to the nearest m³/s value to your required air volume.
 **Reduce Velocity, Increase unit size is the preferred final selection.

Base Models

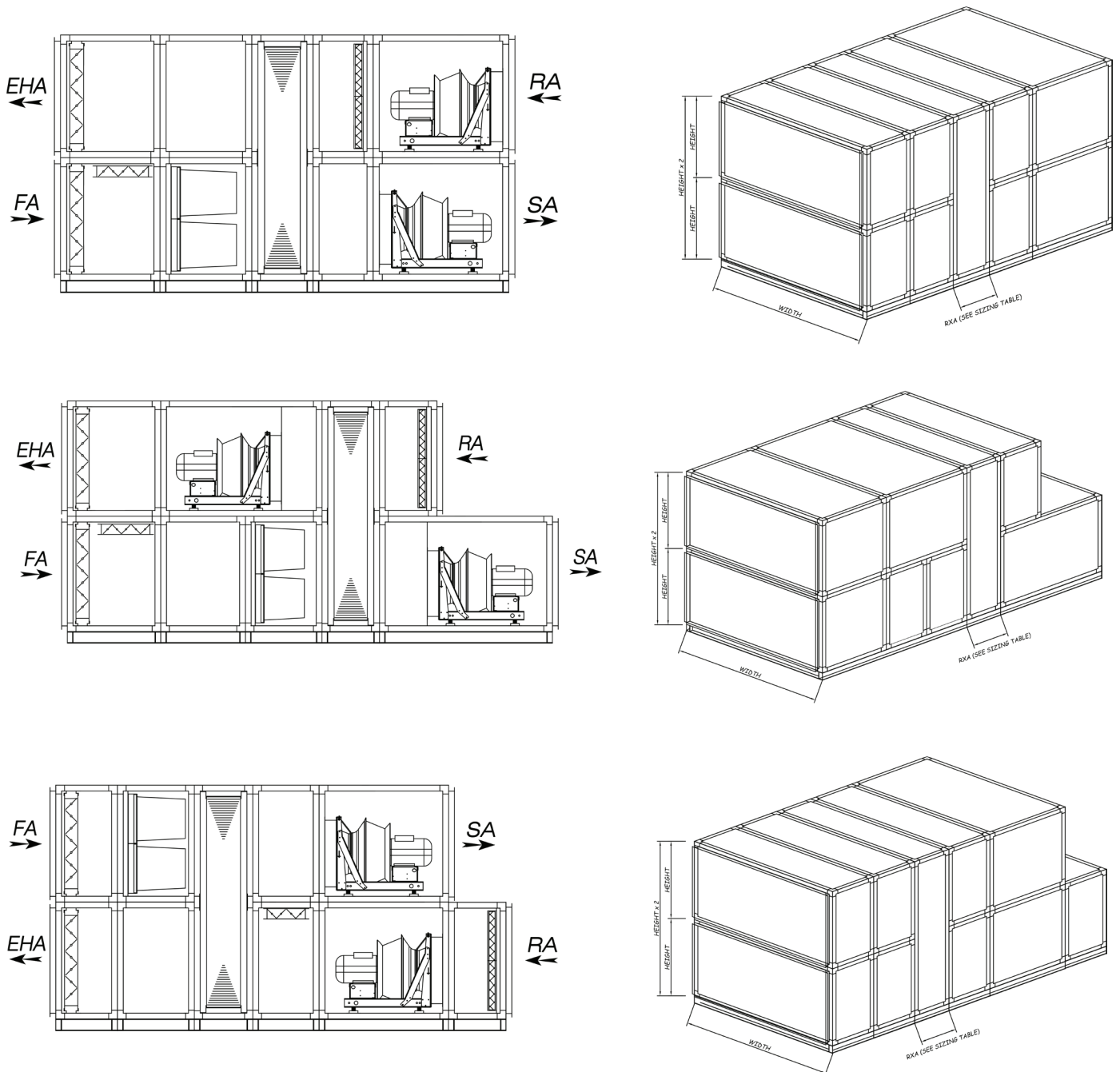

Base models shown are internal FA & EHA dampers for external units, AHU length will reduce by 200mm with external dampers and internal units



AHU Components

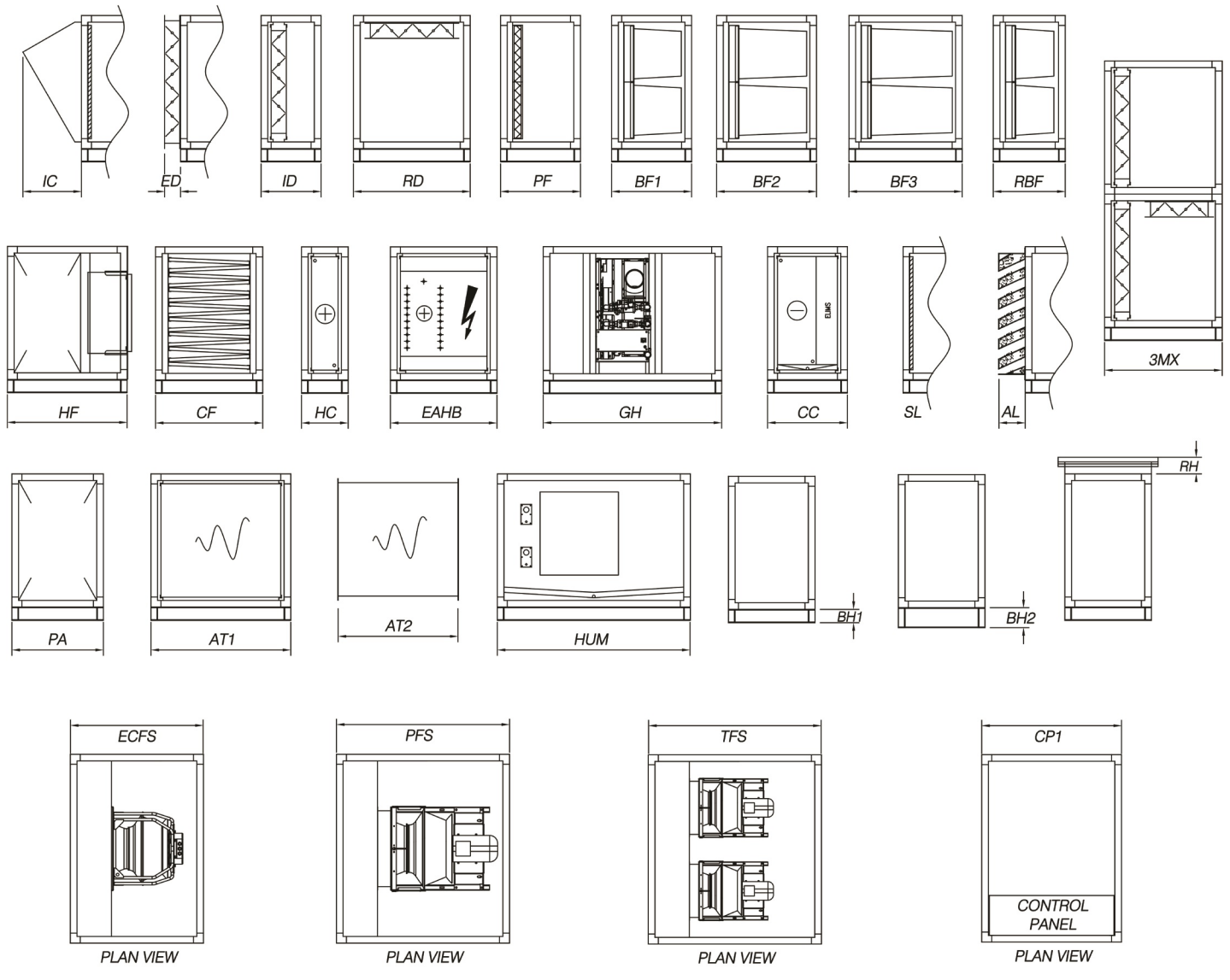

Fan & Control Configurations

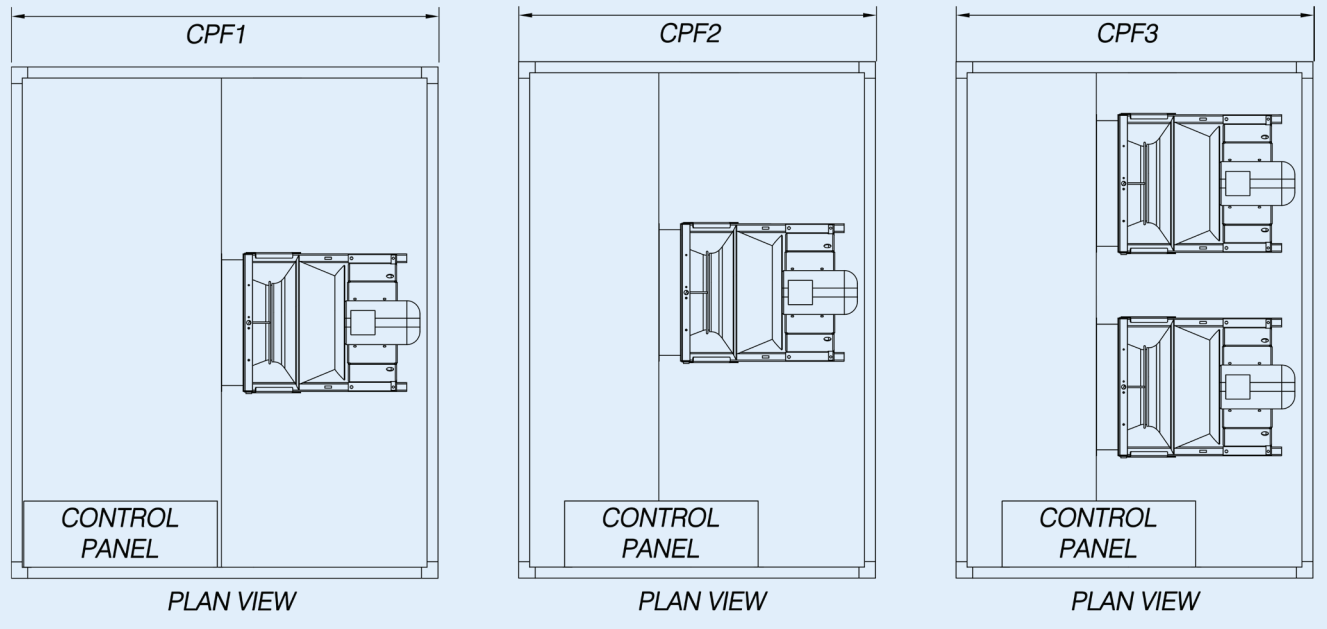



Dimension Table

Dim	Size	1	2	3	4	5	6	7	8	9	10	11	12	13	14
Additional Components Height & Width															
H	Height 25mm Panels	610	610	730	730	880	920	1060	1060	1060	1360	1360	1670	1670	1970
W	Width 25mm Panels	1010	1310	1310	1560	1560	1860	1560	1860	2400	2400	2800	2800	3200	3500
H	Height 50mm Panels	650	650	770	770	920	920	1060	1060	1060	1360	1360	1670	1670	1970
W	Width 50mm Panels	1050	1350	1350	1610	1610	1910	1610	1910	2450	2450	2850	2850	3250	3550
RXA Height															
-	RXA Height 25mm	1220	1220	1460	1460	1760	1840	2120	2120	2120	2720	2720	3340	3340	3940
-	RXA Height 50mm	1300	1300	1540	1540	1840	1840	2120	2120	2120	2720	2720	3340	3340	3940
RXA Width															
-	RXA Width 25mm	1010	1310	1310	1560	1560	1860	1560	1860	2400	2400	2800	2800	3200	3500
-	RXA Width 50mm	1050	1350	1350	1610	1610	1910	1610	1910	2450	2450	2850	2850	3250	3550
Additional Component Lengths															
RXA	Rotary Heat Exchanger	600	600	600	600	600	600	600	600	600	600	600	600	600	600
3MX	3-Way Mix Damper Sect	800	900	1000	1000	1000	1300	1300	1500	1500	1800	1800	1800	2400	2400
IC	Inlet Cowl	200	250	250	250	400	550	550	550	700	700	700	700	700	700
ED	External Damper	120	120	120	120	120	120	120	120	120	120	120	120	120	120
ID	Internal Damper	450	450	450	450	450	450	450	450	450	450	450	450	450	450
PF	Panel Filter	300	300	300	300	300	300	300	300	300	300	300	300	300	300
BF1	Bag 380 - BS EN 16890	600	600	600	600	600	600	600	600	600	600	600	600	600	600
BF2	Bag 535 - BS EN 16890	750	750	750	750	750	750	750	750	750	750	750	750	750	750
BF3	Bag 635 - BS EN 16890	850	850	850	850	850	850	850	850	850	850	850	850	850	850
RBF	Rigid Bag Filter	550	550	550	550	550	550	550	550	550	550	550	550	550	550
HF	HEPA Filter	900	900	900	900	900	900	900	900	900	900	900	900	900	900
CF	Carbon Filter	900	900	900	900	900	900	900	900	900	900	900	900	900	900
HC	Frost / LPHW / Pre / Re Heater	250	250	250	250	250	250	250	250	250	250	250	250	250	250
EAHB	Electric Air Heater Battery	900	900	900	900	900	900	900	900	900	900	900	900	900	900
GH	Gas Heater	1200	1200	1200	1200	1200	1600	1600	1600	1600	1600	1600	1600	1600	1600
CC	Cooler, DX or CH.W	550	550	550	550	550	550	550	550	550	550	550	550	550	550
SL	Standard Louvre	0	0	0	0	0	0	0	0	0	0	0	0	0	0
AL	Acoustic Louvre	300	300	300	300	300	300	300	300	300	300	300	300	300	300
PA	Plenum / Access	600	600	600	600	600	600	600	600	600	600	600	600	600	600
AT1	Attenuator	1050	1050	1050	1350	1350	1350	1350	1350	1350	1650	1650	1650	1650	1650
AT2	Duct Mounted Attenuator	900	900	900	1200	1200	1200	1200	1200	1200	1500	1500	1500	1500	1500
HUM	Humidifier	1200	1200	1200	1200	1200	1200	1600	1600	1600	1600	1600	1600	1600	1600
BH1	Base Height	100	100	100	100	100	100	100	100	100	100	100	100	100	100
BH2	Base Height	150	150	150	150	150	150	150	150	150	150	150	150	150	150
RH	Roof Height	125	125	125	125	125	125	125	125	125	125	125	125	125	125

Dimensions are for roughing in only

Dimension Table

Dim	Size	1	2	3	4	5	6	7	8	9	10	11	12	13	14
Fan & Control Configurations															
ECFS	EC Fan Sect	900	900	900	900	1400	-	-	-	-	-	-	-	-	-
PFS	Plug Fan Sect	900	900	900	900	1300	1500	1500	1500	1900	1600	1600	1600	1800	2100
TFS	Twin Fan Section	-	-	-	-	-	-	1200	1400	1400	1600	1600	1600	1800	2100
CP1	Control Panel Enclosure	800	800	800	800	800	800	800	800	800	800	800	800	800	800
CPF1	Controls Panel Fan Sect	1700	1800	1800	-	-	-	-	-	-	-	-	-	-	-
CPF2	Controls Panel Fan Sect	-	-	-	1200	1300	1300	1500	1700	1700	1700	1700	1700	1700	1700
CPF3	Controls Panel Fan Sect	-	-	-	-	-	-	-	-	1900	1900	1600	1600	1800	2100

AHU Component Dry Weights kg

Dim	Size	1	2	3	4	5	6	7	8	9	10	11	12	13	14
Additional Components															
IC	Inlet Cowl	4	6	7	9	13	17	20	24	29	37	44	54	63	72
ED	External Damper	16	20	23	29	37	45	51	62	76	104	120	172	196	220
ID	Internal Damper	50	58	66	78	92	105	116	134	153	193	215	276	308	341
PF	Panel Filter	32	38	46	51	57	63	77	84	91	111	126	142	189	211
BF1	Bag 380 - BS EN 16890	80	90	106	131	142	158	175	191	220	252	277	310	351	387
BF2	Bag 535 - BS EN 16890	98	110	130	160	173	193	214	233	268	307	338	378	428	472
BF3	Bag 635 - BS EN 16890	108	120	142	176	190	211	235	256	294	338	371	416	470	518
RBF	Rigid Bag Filter	81	91	107	132	143	159	176	192	221	253	278	311	352	388
HF	HEPA Filter	88	102	126	155	182	206	223	253	297	364	409	466	551	607
CF	Carbon Filter	119	164	219	279	368	454	471	563	669	891	1060	1210	1512	1692
RXA	Rotary Heat Exchanger	271	312	362	419	501	606	639	681	927	1005	1106	1793	1850	1907
3MX	3-Way Mix Damper Sect	146	178	213	251	294	376	414	506	571	767	848	1049	1314	1442
HC	Frost / LPHW / Pre / Re Heater	46	53	64	75	91	106	120	138	158	193	219	253	281	315
EHAB	Electric Air Heater Battery	46	53	64	75	91	106	120	138	158	193	219	253	281	315
GH	Gas Heater	84	97	107	140	167	177	235	246	263	290	300	315	465	481
CC	Cooler, DX or CH.W	88	94	141	180	236	296	348	409	488	622	728	880	991	1129
SL	Standard Louvre	4	6	7	9	13	17	20	24	29	37	44	54	63	72
AL	Acoustic Louvre	24	26	27	29	33	37	40	44	49	57	64	74	83	92
PA	Plenum/Access	75	84	96	110	122	135	146	160	172	198	213	232	251	270
AT1	Attenuator	107	123	147	174	212	252	287	324	375	460	523	612	715	819
AT2	Duct Mounted Attenuator	140	161	193	229	279	332	378	427	495	606	691	808	945	1083
HUM	Humidifier	109	118	130	144	190	203	214	228	274	375	421	450	530	559
BH1	Base 100mm High 1000L	6	6	6	6	6	10	10	10	10	15	15	15	15	20
BH2	Base 150mm High 1000L	7	7	7	7	7	11	11	11	11	16	16	16	16	22
RH	Roof Section 1000L	10	11	14	17	17	18	19	23	23	28	28	28	32	36
	Floor Grid 1000W	-	-	-	-	-	24	-	24	34	43	43	43	51	58
	25mm Acoustic Treatment	5	5	5	5	5	5	5	5	5	5	5	5	5	5
	50mm Acoustic Treatment	10	10	10	10	10	10	10	10	10	10	10	10	10	10
Water		Weight of water in coils (kg) = 5.3 x face area m ² x number of rows. Cooling generally 4-6 rows, heating generally 1-2 rows.													



Fan & Control Configuration Weights kg

Dim	Size	1	2	3	4	5	6	7	8	9	10	11	12	13	14
Fan & Control Configurations															
ECFS	EC Fan Sect	133	147	165	187	314	-	-	-	-	-	-	-	-	-
PFS	Plug Fan Sect	140	173	191	212	359	483	510	545	812	797	993	1042	1177	1370
TFS	Twin Fan Section	-	-	-	-	-	-	432	563	590	820	860	910	1193	1483
CP1	Control Panel Enclosure	110	122	138	161	182	201	234	242	268	294	314	338	384	410
CPF1	Controls Panel Fan Sect	249	309	345	-	-	-	-	-	-	-	-	-	-	-
CPF2	Controls Panel Fan Sect	-	-	-	281	378	458	535	623	780	860	1063	1116	1175	1230
CPF3	Controls Panel Fan Sect	-	-	-	-	-	-	-	-	763	954	900	949	1237	1523

Weight of fan sections shown are with the largest fan possible for each size section. Weight will reduce when using a smaller fan or fans.

Controls Partner

Heat Recovery Efficiency

As part of our RXA3MX range of Air Handling Units we are able to supply our Intelligent Energy Control (IEC) system.

The IEC system is powerful, flexible, user-friendly and specifically designed to provide a complete control solution for Air Handling and Conditioning Systems.

At the heart of our IEC solution is the fully programmable IQ4 controller which is housed within an IP65 enclosure.

Further to this our IEC system will interface with many manufacturers equipment including but not limited to Mitsubishi, Daikin, Toshiba, Samsung and Panasonic and has the facility to support many protocols; these include Modbus, BACnet, LonWorks, and SNMP.

As of the 1st of June 2018 our customers who purchase the IEC system will receive a 5-year limited hardware Warranty on our IQ4 controllers and modules.

Forward Thinking

As a controls partner we strive to maintain a position at the forefront of technology, and have developed considerable expertise in manufacturing both the hardware and software that makes up the Intelligent Energy Control system.

The greatest advantage ECE has from being able to design and manufacture the software and hardware, is that it greatly strengthens the company's ability to set the technological innovation and design standards throughout our industry.

Two of our latest IEC technological developments benefiting our customers are Economy Mode and Intelligent Frost Protection.

Economy Mode

Economy Mode has three stages of system efficiency including economy cycle, free cooling and energy recovery.

This system can offer incredible savings to end users and reduce air handling unit motor energy consumption by up to 50%.

Intelligent Frost Protection

Our Intelligent Frost Protection will monitor internal condition of the building during night shutdown and protect the building fabric. The units will achieve this by running for short periods every two hours (user adjustable) to read the return air temperature. If after 10 minutes of operation the return air temperature is above the non-occupied temperature set point the unit will be disabled until the next start cycle.

If any of the units read a temperature below the minimum non-occupied temperature set point, that unit will operate until the return air temperature rises above the non-occupied temperature set point.



Air Handling Unit Construction

At ECE UK we have improved the design of our equipment over the last forty years offering a cost-effective solution including L2 Leakage Class, D1 Deflection Class, TB1 Thermal Bridging and T2 thermal Transmittance. This is complimented by achieving standards set out in ERP 2016/18 and L2 Specific Fan Power.

To further ensure structural stability, rigidity and thermal qualities BS EN 1886:2007 standard provides the means for classifying the performance of all our air handling units.

The Air Handling Unit framework is constructed from a closed aluminium box section with heavy duty injection moulded ABS black nylon knock in corner pieces. This high density and lightweight structure ensures a strong and rigid framework for the Air Handling Unit.

Depending upon the project requirements panels can be either 25mm or 50mm thick. Panels are constructed from a galvanised sheet steel inner skin with a plastisol coated or galvanised sheet steel outer skin with mineral wool insulation sandwiched between the sheets. Our standard plastisol colour is Goosewing Grey RAL10A05, other colours are available on request.

Our standard mineral wool insulation has a density of 100kg/m3.

As standard each complete unit or modular section would be factory assembled on a full perimeter base to ensure full structural stability.

All externally mounted units would be fully sealed and completed with an overhanging pitched roof to prevent water ingress.

Depending upon site access all of our Air Handling Units can be supplied as modular sections, component form or fully assembled on a single piece base frame and still conform to the standards set out above.

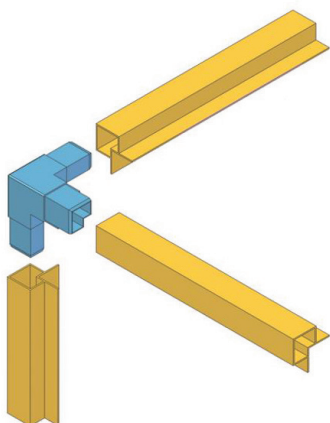
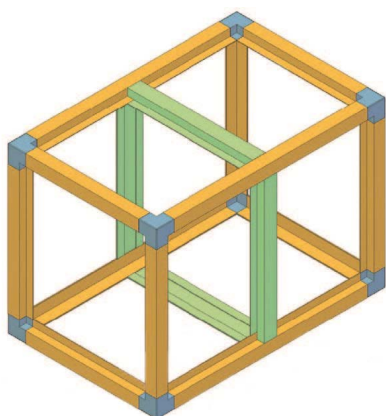

Asset Information

This AHU mounted web based portal augments our customer experience by providing you with all your BIM Level 2 files for your job specific, bespoke, Air Handling Unit as defined at the design stage.



Asset Information

Either show the QR code to your code reader app of choice, or visit <https://asset.eceuk.com/> and enter the reference number below

682 528 185 640 707 446



Pharaoh House, Arncliffe Close, Medway City Estate,
Rochester, Kent ME2 4QW
www.eceuk.com e mail : affersales@eceuk.com

This allows building maintenance teams, consultants and contractors unique access to one of the most productive portals available.

Here is just some of the great features that our portal offers:

- 3D models to go into your Building Management System, such as Revit (.step, .sat, .ifc, .dwg (3D), etc).
- 3D models that can be interacted with in real-time using augmented reality devices (such as a Microsoft HoloLens).
- 2D Certified Drawings (.dwg for loading into AutoCAD / DraftSight and .pdf for opening on any device, anywhere).
- Consumables Information (such as Filters, Motors, Sensors and Actuators).
- Single click Basket for consumables with Anything Air Handling, our Spares & Parts shop www.aahuk.com.
- Controls Documents (if your AHU has one of our controls package).
- Refrigeration Unit Information.
- Installation, Operation and Maintenance Manual.
- Recycling Manual.

All you need to access this information is a unique reference number and an email address. To make it really easy each of our units now come with an Asset Information plate allowing you on-premises access to all the information from your mobile device.

TRY IT! Scan the QR and enter the code



Did you know...?

- on a DX system the indoor coil is mounted internal to the AHU and outdoor coil is the condensing unit.
- when matching indoor to outdoor coils HEX volume, Air Volume, Coil Capacity and Coil Circuitry should match.
- at peak times during summer and winter, outdoor coil capacities on DX systems can reduce by up to 20%. Dependent on ambient temperatures.
- minimum air on temperature in heating mode for a DX system indoor coil is 10°C.
- swings in temperature are often caused by DX run on times and single circuit DX systems supplying small areas. This is more prevalent in small areas and with air volumes below 1.0 m³/s. Twin circuits will often reduce the risk of this happening.
- by supplying twin circuits you reduce the risk of cold air being pumped into the area served when one circuit is in defrost.
- some DX units have eleven capacity steps whereas others may only have five.
- the term "vertical unit" has the same meaning as double stacking and or piggy back arrangement.
- if you're concerned about the equipment access route, ECE can offer a free site survey.
- ECE can offer a long reach HIAB vehicle with a reach of 27 meters holding one tonne.
- if ECE supply the AHU, Controls and DX equipment the AHU warranty is extended to two years.
- ECE offer a 5 year warranty on its iQ range of controllers.
- ECE offer a 5 year warranty on its DX units.
- ErP requires supply systems to have minimum ePM 2.5 50% grade filtration.
- Location, Internal or External.
- Delivery in modules or packaged in one piece (dimensions limits apply).
- Units also available "Dry Built" for site off load, dismantle, carry through, re-assemble, join and seal.
- Units also available in component form for site offload, carry through, re-assemble, join and seal.
- Fewer pressure producing components reduces the overall energy consumption thus reducing carbon footprint, SFP and running costs of the AHU.
- AHU cooler and heater duties will incorporate coolth and heat recovery capacity and reduce the size of the indirect or direct heating and cooling equipment. This will reduce the indirect or direct heating and cooling equipment cost to the client by up to 20%.
- AHU's can include EC Fans (IE4 Motors) to give the highest possible efficiency and the lowest life cycle cost.
- By removing the frost coil this increases heat recovery efficiency as the delta t between return air and fresh air is greater. Thus more energy is available for recovery.

ECE UK Ltd.

T +44 (0)1634729690
E sales@eceuk.com
W www.eceuk.com
A Pharaoh House, Arnolde
Close, Rochester, Kent,
ME2 4QW

