



# Run Around Coil 3-Way Mix RAC3MX



Selection Data





# Company Profile

ECE UK Ltd is a privately owned company that was established in 1979 by the existing directors and shareholders. We operate from our 4,000m<sup>2</sup> manufacturing facility in Rochester where we produce air handling / conditioning units and controls of the highest quality; which is reflected by our level of customer retention.

With forty years of experience, we are a leader in the field of air handling, conditioning and control systems.

Our experienced and knowledgeable members of staff have obtained qualifications from HNC to Master's Degree. To compliment this we provide an in-house and external training programme. We are committed to working in partnership with Consultants, Contractors and End-Users, providing added value through technical innovation, service excellence and the ability to provide energy efficient solutions.

ECE UK offers a wide range of Products and Services that complement our RAC range of Air Handling Units including:

## Air Conditioning

Heat pump units and interconnecting refrigeration pipe work.

## Controls

Trend Control systems either mounted internal to AHU or remote.

## Site Wiring

Our qualified engineers would install all interconnecting control wiring external to the air handling unit along agreed routes.

## Plant Movement

Refurbishment, Removal, and Installation of Air Handling Units, Air Conditioning Units and Controls.

## After Sales

Warranty assistance and troubleshooting of site issues for Air Handling Units, Air Conditioning Units and Control Systems.

## Service & Maintenance

Platinum, Gold and Silver maintenance packages for Air Handling Units, Air Conditioning Units and Control Systems.

**By providing the many Products and Services in one place we can offer you the convenience of obtaining all your ventilation, air conditioning and control requirements from one manufacturer.**

# RAC3MX Explained

## Heat Recovery Efficiency

Dependent on the right conditions, heat recovery efficiencies can reach 70%. The correct efficiency is a subjective decision and depends on the economic calculation and written guidelines, i.e. Eco-design Commission Regulation (EU) No 1253/2014, on operating data such as energy prices, useful life, running times, temperatures, maintenance costs and interest rates. With regard to (EU) No 1253/2014, profitability and environmental protection the heat recovery efficiency should be no less than 68%.

## Operation

It is common for the supply and extract air handlers containing the run around coil system to be joined together, either in a side-by-side or a stacked configuration. However if required the units can be separated and up to 15m apart.

A run-around coil system comprises two or more multi-row finned tube coils connected to each other by a pumped pipework circuit. The pipework is charged with a heat exchange fluid, water, which picks up heat from the exhaust air coil and gives up heat to the supply air coil before returning again. Thus heat from the exhaust air stream is transferred through the pipework coil to the circulating fluid, and then from the fluid through the pipework coil to the supply air stream.

From this process the specific heat output capacity depends on the temperature difference between the two air streams. Hence the coil is suitable for heat as well as cool recovery, i.e. for winter and summer operation.

The AHU air-mixing plenum combines two air streams. The configuration includes three sets of dampers: one for the fresh air, one for the exhaust air, and a mixing damper between the two air streams. The mix of fresh air and recirculated air can thus be adjusted to suit the needs of the building's occupants. Typically as the fresh air and exhaust air dampers are driven from 0% open to 100% open, the mixing damper will in turn be driven from 100% open to 0% open, so as to always ensure a constant volume of supply and extract air.

## Intelligent Energy Control

Either our Intelligent Energy Control system or the clients BMS may monitor the return air quality, energy efficiency available to recover or CO<sub>2</sub> concentration for optimum energy efficiency whilst maintaining desired fresh air requirements. Additionally, when outside air conditions are such, typically mid-season weather conditions, it may be that ambient temperatures are suitable for free cooling purposes.



## Basic Principles

The use of a run-around coil system is generally limited to applications where the air streams are separated and no other type of device can be utilised since the heat recovery efficiency is lower than other forms of air-to-air heat recovery.

The fluid circuit, as well as containing the circulating pump, will also contain an expansion vessel, to accommodate changes in fluid pressure; a fill device, to ensure the system remains charged; controls to bypass and shut down the system when not required, and various other safety devices and ancillaries.

Pipework runs should be kept as short as possible and should be sized for low velocities to keep frictional losses to a minimum, and hence reduce pump energy consumption. It is possible however to recover some of this energy in the form of heat given off by the motor if a glandless pump is used, where a water jacket surrounds the motor stator, thus water passing through the pump will pick up some of its heat.

The pumped fluid will have to be protected from freezing in certain climates, and as such is normally treated with a glycol based anti-freeze. This also reduces the specific heat capacity of the fluid and increases the viscosity, increasing pump power consumption. For example, a 20% glycol mixture will provide protection down to  $-10^{\circ}\text{C}$  ( $14^{\circ}\text{F}$ ), but will increase system resistance by 15%.

For the finned tube coil design, there is a performance maximum corresponding to an 12 to 14 row coil, above this the fan and pump motor energy consumption increases substantially and seasonal efficiency starts to drop off. The main cause of increased energy consumption lies with the fan, for the same face velocity, fewer coil rows will decrease air pressure drop and increase water pressure drop but the total energy consumption will usually be less than that for a greater number of coil rows with higher air pressure drops and lower water pressure drops.

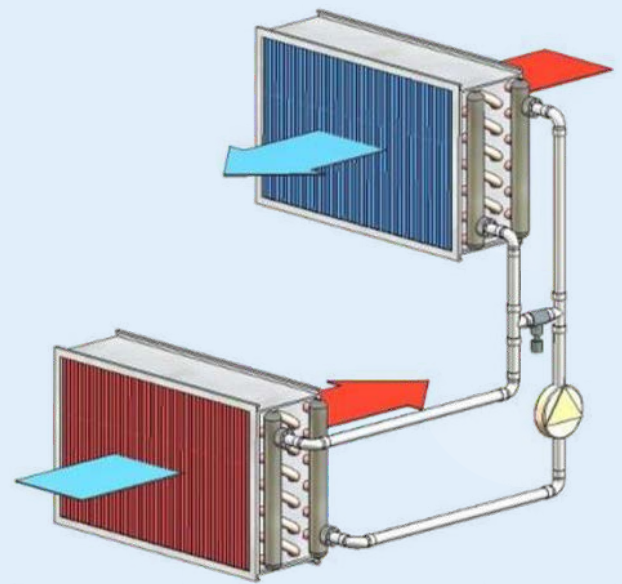

## Ancillary Items

Air filtration is always present in order to provide clean dust-free air to the building occupants.

Direct heating, placed directly in the air stream, are direct heat exchangers and include those for gas-fired fuel-burning heaters or electric air heater batteries (EAHB). Indirect Heating and Cooling coils use hot water or steam for heating, and chilled water for cooling. Heat pumps can be used as well. (Prime energy for heating and cooling is provided by central plant).

Humidification is often necessary in colder climates where continuous heating will make the air drier, resulting in uncomfortable air quality and increased static electricity. Various types of humidification may be used as part of our air handler and include evaporative, vaporizer, spray mist and wetted medium.

If dehumidification is required, then the cooling coil is employed to over-cool so that the dew point is reached and condensation occurs. A heater coil placed after the cooling coil re-heats the air to the desired supply temperature and humidity level. This is often used for chilled beam applications.

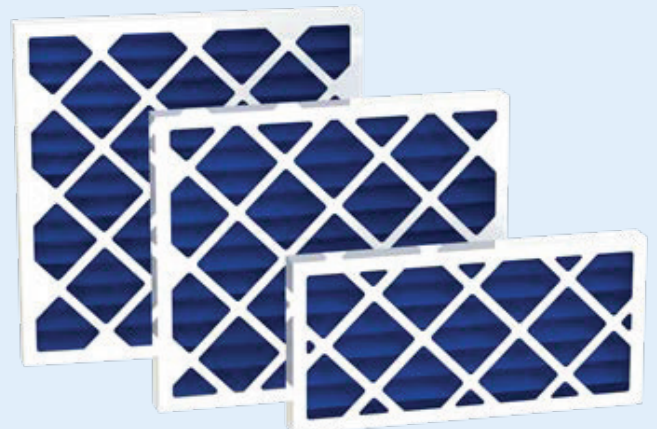

## Single Pressurisation Pump, Single Circulating Pump

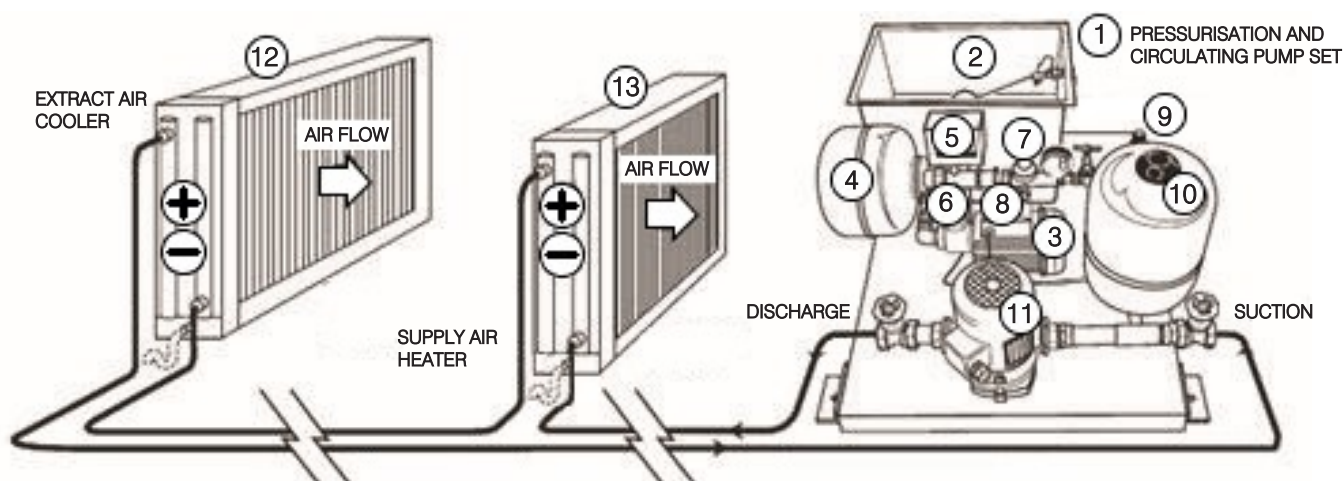

1. Mains in - if fitted and not hand fill & top up during maintenance.
2. Break tank with ball valve, type A air gap and lid.
3. Pressurisation pump.
4. Expansion vessel controlling pressurisation pump.
5. Pressurisation pump, pressure control switch
6. Dial gauge 0 - 100 psi, 0 - 7bar
7. Pressure regulator
8. Dial gauge 0 - 4 bar red line at 3 bar.
9. 6 Bar safety valve (partly hidden)
10. Pressurized system expansion vessel
11. Circulation pump
12. Extract air runaround heat and coolth recovery coil with eliminators, drain pan & condensate drain connection drain trap & drain fitted on site.
13. Supply air runaround heat and coolth recovery coil with eliminators, drain pan & condensate drain connection drain trap & drain fitted on site.

## Single Pressurisation Pump, Twin Circulating Pumps with Flow Switch and Auto Changeover

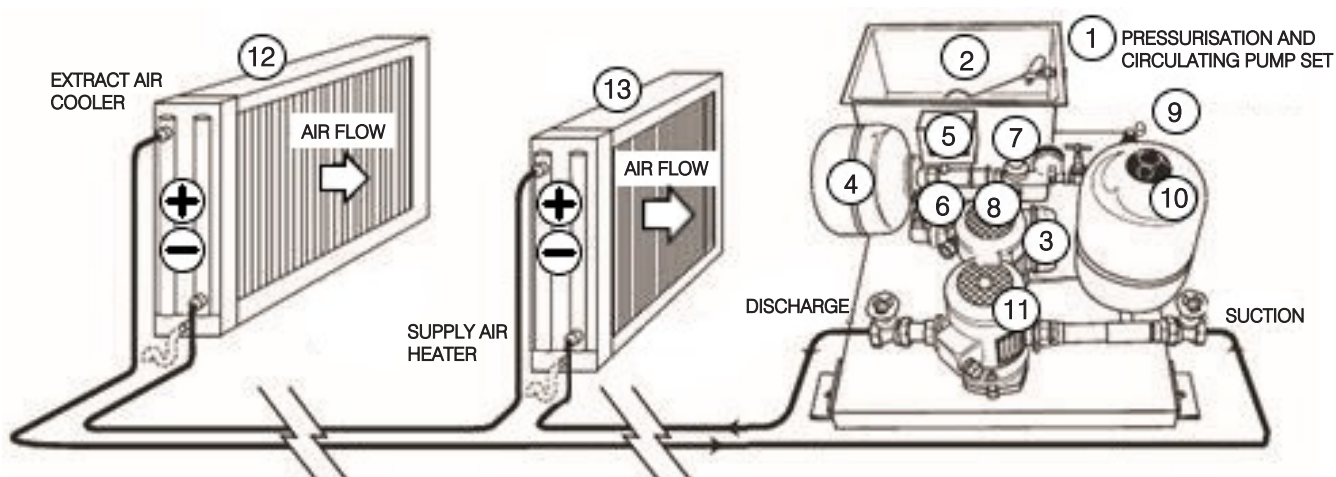

1. Mains in – if fitted and not hand fill & top up during maintenance
2. Break tanks with ball valve, type A air gap and lid
3. Pressurisation pump
4. Expansion vessel controlling pressurisation pump
5. Pressurisation pump, pressure control switch
6. Dial gauge 0 – 100 psi 0 – 7 bar
7. Pressure regulator
8. Dial gauge 0 – 4 bar red line at 3 bar
9. 6 Bar safety valve (partly hidden)
10. Pressurised system expansion vessel
11. Duty and standby twin, common manifold) pumps
12. Extract air runaround heat and coolth recovery coil with eliminators, drain pan & condensate drain connection drain trap & drain fitted on site.
13. Supply air runaround heat and coolth recovery coil with eliminators, drain pan & condensate drain connection drain trap & drain fitted on site.



# Popular RAC3MX Configurations

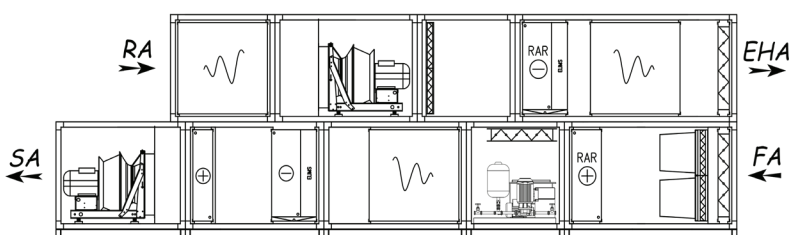
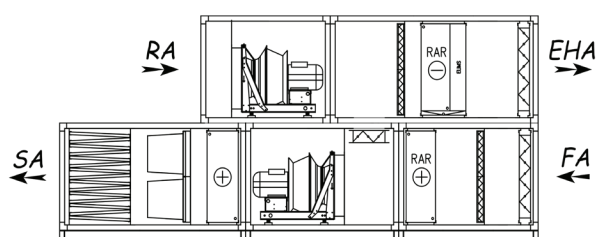
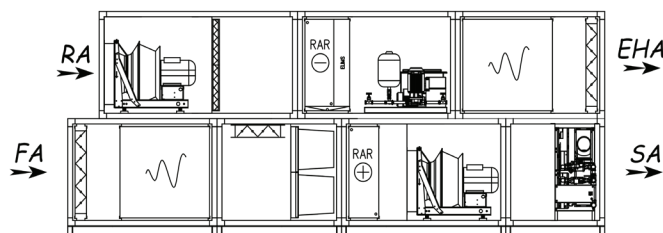
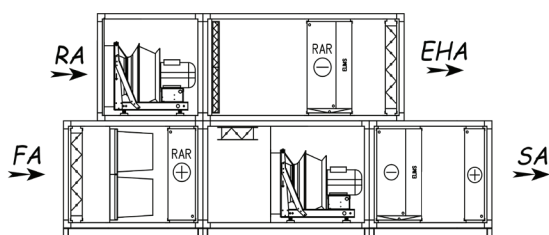
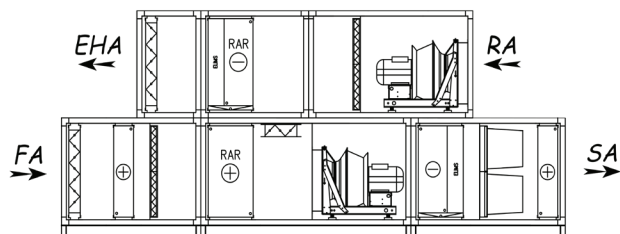

## Selection Information

- Dimensions on pages 8 & 9 are for roughing in only.
- To keep specific fan power (SFP) within ERP 2016 and L2 requirements, the following should be adhered to:
  - For AHU's with external system resistance <math>< 200\text{Pa}</math> for both supply and extract systems, keep the face velocity between 2.5 and 3.0 m/s.
  - For AHU's with external system resistance between 200Pa – 400Pa for both supply and extract systems, keep the face velocity between 2.0 and 2.5 m/s and include 635mm long bag filters.
- Contact technical sales for specials if unit sizes are difficult to accommodate.
- Fan total pressures from 100Pa to 1500Pa (including AHU internal losses).
- Maximum external pressure available i.e. AHU inlet negative pressures plus AHU discharge positive pressure = fan static pressure less AHU internal component resistances for both extract and supply AHU's.
- Height and width dimensions in tables are the AHU frame outside dimensions. Add base dimension, also add roof dimension (RH) if unit is external.
- Component length dimensions are space that each internal component occupies.
- Maximum overall AHU length unlimited. (Maximum single piece size subject to transport restrictions).
- Frame inlet connections generally 30mm up to size 5 and 50mm size 6 and above, around frame perimeter, undrilled.
- Inlet connections can be mezz flanges 30mm and 40mm as required.
- Outlet fan connections from unit – see dimension tables.
- If fresh air intake is at the bottom of the AHU and the supply sits at the top of the AHU the extract section at the bottom of the AHU will need blank plenums to support the supply.
- Individual section lengths including components like coils, attenuators or filters can range from 300mm to 2400mm. Each individual component does not have to sit within its own section.
- It is possible to have up to 4 stages of filtration on both the supply and extract air streams.
- "X" dimension will only be required if the supply or extract fan is downstream of a full face component, other than the plate heat exchanger.
- Due to ERP 2016, level of filtration to always be F7 grade supply and M5 grade on extract.
- Gas heaters should be the last component in supply air configuration.
- Due to height restrictions, floor grid available from unit sizes 6 to 15 only. No need for floor grid if walk in access is not available.



# Velocity Chart

(Vc)m/s	VOLUME m <sup>3</sup> /s AT COIL FACE VELOCITIES (Vc) m/s	Unit Size																
		1	2	3	4S	4	5	6	7	8	9	10S	10	11	12	13	14	15
1.75		0.36	0.52	0.75	1.09	1.09	1.52	2.16	2.55	3.14	3.99	4.85	5.33	6.47	7.99	9.47	10.98	12.10
2.0		0.42	0.61	0.87	1.2	1.2	1.85	2.54	2.98	3.65	4.64	5.6	6.18	7.51	9.5	10.82	12.53	13.8
2.25		0.47	0.68	0.97	1.35	1.35	2.09	2.86	3.35	4.12	5.22	6.3	6.95	8.44	10.69	12.17	14.09	15.53
2.5		0.52	0.76	1.08	1.5	1.5	2.32	3.17	3.73	4.56	5.81	7.1	7.73	9.39	11.88	13.53	15.66	17.26
2.75		0.58	0.83	1.19	1.65	1.65	2.55	3.48	4.1	5.02	6.39	7.7	8.5	10.32	13.07	14.88	17.23	18.99
3.0		0.63	0.91	1.3	1.8	1.8	2.78	3.8	4.47	5.48	6.97	8.4	9.28	11.27	14.25	16.23	18.79	20.71
3.25		0.67	0.99	1.41	1.95	1.95	3.01	4.12	4.85	5.94	7.56	9.1	10.05	12.2	15.44	17.58	20.36	22.44

\*Please select unit size from the above table using the velocity first, then to the nearest m<sup>3</sup>/s value to your required air volume.  
 \*\*Reduce Velocity, Increase unit size is the preferred final selection.

## Base Models

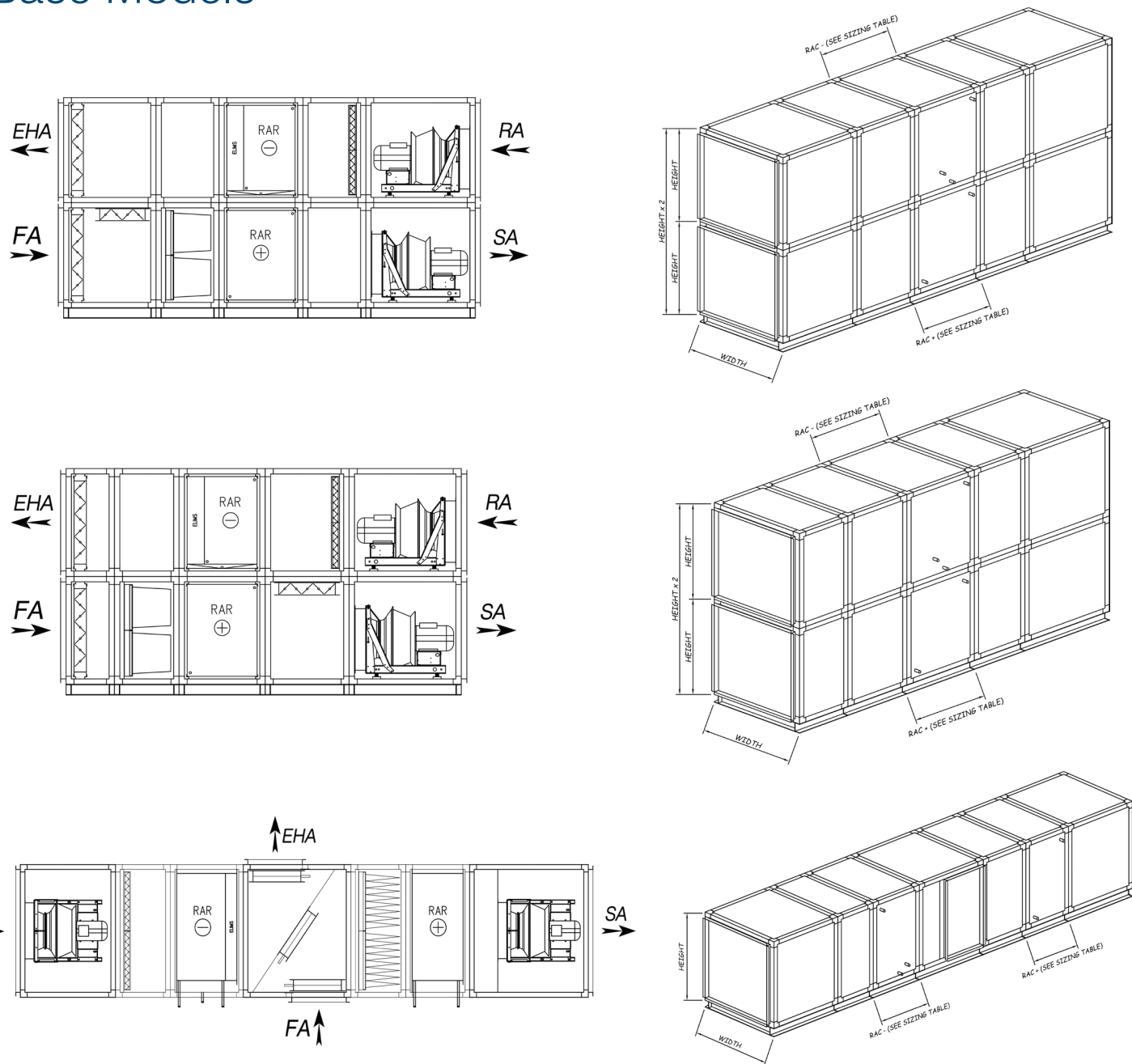

Base models shown are internal FA & EHA dampers for external units, AHU length will reduce by 200mm with external dampers and internal units  
 Please note: Base models are examples only and if required, Supply and Extract Decks can be separated and placed within 15m of each other



# AHU Components

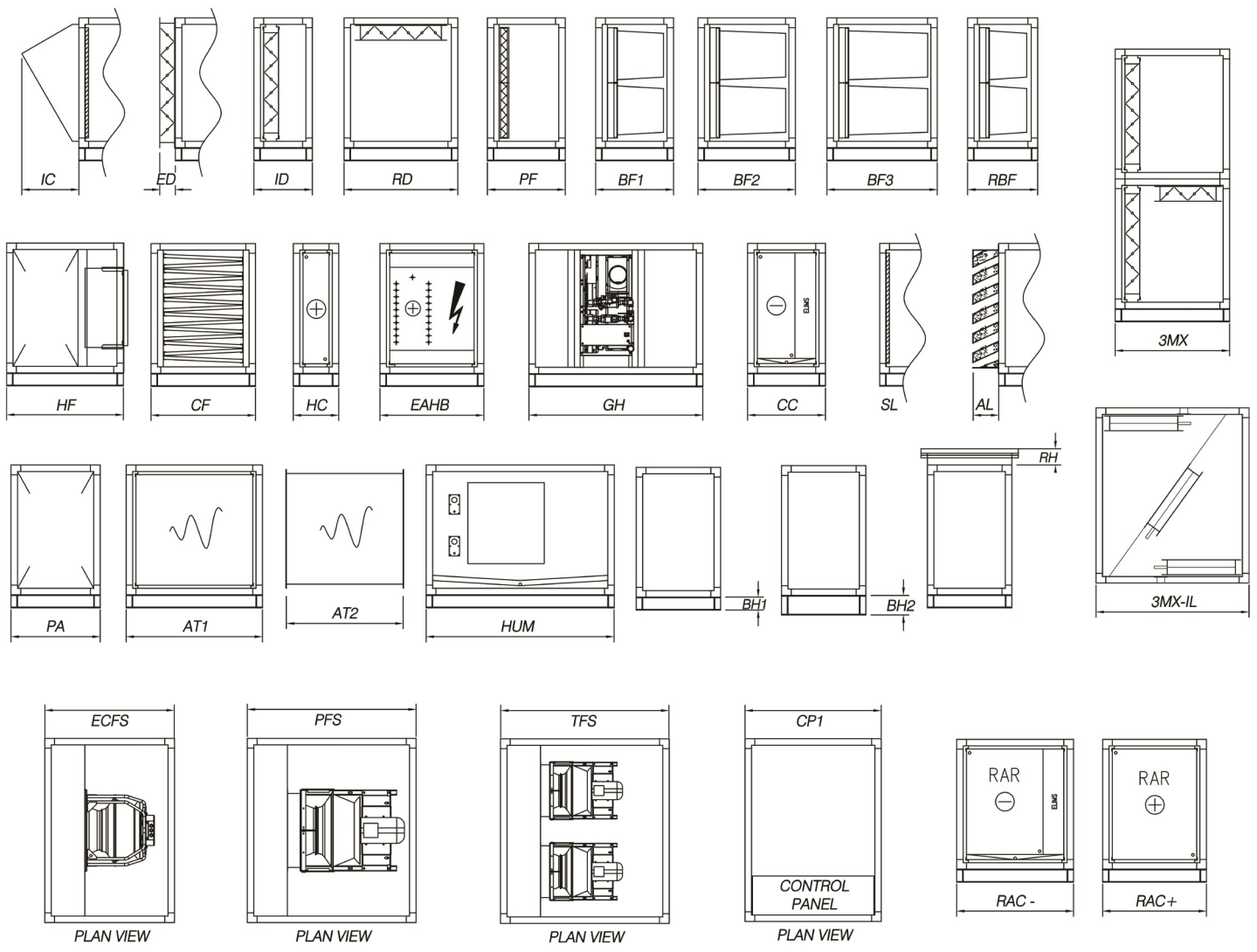

# Fan & Control Configurations

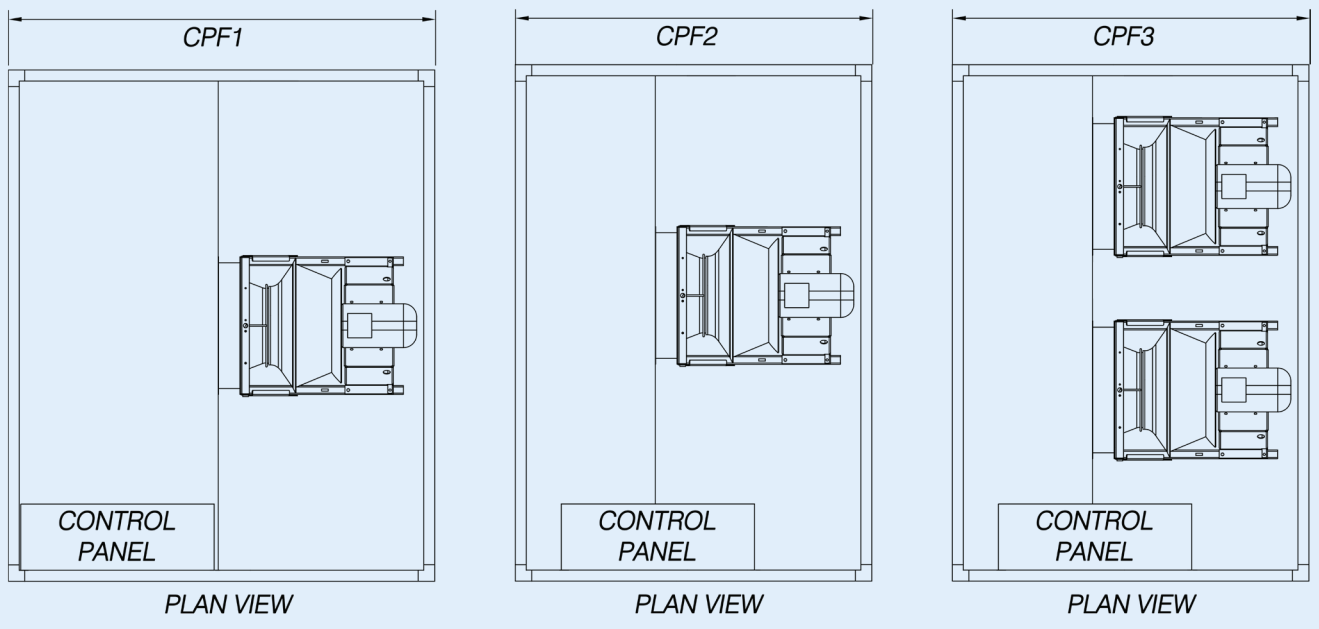



# Dimension Table

Dim	Size	1	2	3	4S	4	5	6	7	8	9	10S	10	11	12	13	14	15
Additional Components Height & Width																		
H	Height 25mm Panels	610	730	730	1020	730	1020	1360	1360	1360	1670	1970	1670	1970	2400	2400	2400	2400
W	Width 25mm Panels	690	780	1010	1010	1310	1310	1360	1560	1860	1860	1860	2400	2400	2400	2800	3200	3500
H	Height 50mm Panels	650	770	770	1060	770	1060	1360	1360	1360	1670	1970	1670	1970	2400	2400	2400	2400
W	Width 50mm Panels	730	820	1050	1050	1350	1350	1410	1610	1910	1910	1910	2450	2450	2450	2850	3250	3550
Double Stacked RAC3MX Height																		
-	Double Stacked RAC3MX Height 25mm	1220	1460	1460	2040	1460	2040	2720	2720	2720	3340	3940	3340	3940	4800	4800	4800	4800
-	Double Stacked RAC3MX Height 50mm	1300	1540	1540	2120	1540	2120	2720	2720	2720	3340	3940	3340	3940	4800	4800	4800	4800
Additional Component Lengths																		
RAC -	Run Around Coil Extract	900	900	900	900	900	900	900	900	900	900	900	900	900	900	900	900	900
RAC +	Run Around Coil Supply	800	800	800	800	800	800	800	800	800	800	800	800	800	800	800	800	800
IC	Inlet Cowl	200	250	250	250	250	400	550	550	550	700	700	700	700	700	700	700	700
ED	External Damper	120	120	120	120	120	120	120	120	120	120	120	120	120	120	120	120	120
ID	Internal Damper	450	450	450	450	450	450	450	450	450	450	450	450	450	450	450	450	450
RD	Re-Circulating Damper	400	500	600	600	600	600	900	900	1100	1100	1400	1400	1400	1400	2000	2000	2000
PF	Panel Filter	300	300	300	300	300	300	300	300	300	300	300	300	300	300	300	300	300
BF1	Bag 380 - BS EN 16890	600	600	600	600	600	600	600	600	600	600	600	600	600	600	600	600	600
BF2	Bag 535 - BS EN 16890	750	750	750	750	750	750	750	750	750	750	750	750	750	750	750	750	750
BF3	Bag 635 - BS EN 16890	850	850	850	850	850	850	850	850	850	850	850	850	850	850	850	850	850
RBF	Rigid Bag Filter	550	550	550	550	550	550	550	550	550	550	550	550	550	550	550	550	550
3MX	3-Way Mix Damper Sect	800	900	1000	1000	1000	1000	1300	1300	1500	1500	2000	1800	1800	1800	2400	2400	2400
3MX-IL	3-Way Mix Damper Inline	1100	1100	1200	1600	1400	1600	1800	2000	2400	2400	3400	3400	3400	3400	4200	4200	4500
HF	HEPA Filter	900	900	900	900	900	900	900	900	900	900	900	900	900	900	900	900	900
CF	Carbon Filter	900	900	900	900	900	900	900	900	900	900	900	900	900	900	900	900	900
PSE	Pump Set Enclosure	900	900	900	900	900	900	1200	1200	1200	1200	1500	1500	1500	1500	1500	1500	1500
HC	Frost / LPHW / Pre / Re Heater	250	250	250	250	250	250	250	250	250	250	250	250	250	250	250	250	250
EAHB	Electric Air Heater Battery	900	900	900	900	900	900	900	900	900	900	900	900	900	900	900	900	900
GH	Gas Heater	1200	1200	1200	1200	1200	1200	1600	1600	1600	1600	1600	1600	1600	1600	1600	1600	1600
CC	Cooler, DX or CH.W	550	550	550	550	550	550	550	550	550	550	550	550	550	550	550	550	550
SL	Standard Louvre	0	0	0	0	0	0	0	0	0	0	0	0	0	0	0	0	0
AL	Acoustic Louvre	300	300	300	300	300	300	300	300	300	300	300	300	300	300	300	300	300
PA	Plenum / Access	600	600	600	600	600	600	600	600	600	600	600	600	600	600	600	600	600
AT1	Attenuator	1050	1050	1050	1350	1350	1350	1350	1350	1350	1350	1650	1650	1650	1650	1650	1650	1650
AT2	Duct Mounted Attenuator	900	900	900	1200	1200	1200	1200	1200	1200	1200	1500	1500	1500	1500	1500	1500	1500
HUM	Humidifier	1200	1200	1200	1200	1200	1200	1200	1600	1600	1600	1600	1600	1600	1600	1600	1600	1600
BH1	Base Height	100	100	100	100	100	100	100	100	100	100	100	100	100	100	100	100	100
BH2	Base Height	150	150	150	150	150	150	150	150	150	150	150	150	150	150	150	150	150
RH	Roof Height	125	125	125	125	125	125	125	125	125	125	125	125	125	125	125	125	125

Dimensions are for roughing in only





# Dimension Table

Dim	Size	1	2	3	4S	4	5	6	7	8	9	10S	10	11	12	13	14	15	
Fan & Control Configurations																			
ECFS	EC Fan Sect	900	900	900	1200	900	1400	-	-	-	-	-	-	-	-	-	-	-	-
PFS	Plug Fan Sect	900	900	900	1200	900	1300	1500	1500	1500	1900	1900	1600	1600	1600	1800	2100	2100	
TFS	Twin Fan Section	-	-	-	-	-	-	-	1200	1400	1400	1400	1600	1600	1600	1800	2100	2100	
CP1	Control Panel Enclosure	800	800	800	800	800	800	800	800	800	800	800	800	800	800	800	800	800	800
CPF1	Controls Panel Fan Sect	1700	1800	1800	1800	-	-	-	-	-	-	-	-	-	-	-	-	-	-
CPF2	Controls Panel Fan Sect	-	-	-	-	1200	1300	1300	1500	1700	1700	1700	1700	1700	1700	1700	1700	1700	1700
CPF3	Controls Panel Fan Sect	-	-	-	-	-	-	-	-	-	1900	1600	1900	1600	1600	1800	2100	2100	

# AHU Component Dry Weights kg

Dim	Size	1	2	3	4S	4	5	6	7	8	9	10S	10	11	12	13	14	15	
Additional Components																			
RAC-	Run Around Coil Extract	158	170	253	324	324	401	488	574	654	780	995	995	1092	1320	1486	1693	1723	
RAC+	Run Around Coil Supply	142	153	227	291	291	360	439	516	588	702	859	895	982	1188	1337	1523	1550	
IC	Inlet Cowl	4	6	7	9	9	13	17	20	24	29	37	37	44	54	63	72	79	
ED	External Damper	16	20	23	29	29	37	45	51	62	76	104	104	120	172	196	220	240	
ID	Internal Damper	50	58	66	78	78	92	105	116	134	153	193	193	215	276	308	341	368	
PF	Panel Filter	32	38	46	51	51	57	63	77	84	91	111	111	126	142	189	211	227	
BF1	Bag 380 - BS EN 16890	80	90	106	131	131	142	158	175	191	220	252	252	277	310	351	387	416	
BF2	Bag 535 - BS EN 16890	98	110	130	160	160	173	193	214	233	268	307	307	338	378	428	472	507	
BF3	Bag 635 - BS EN 16890	108	120	142	176	176	190	211	235	256	294	338	338	371	416	470	518	557	
RBF	Rigid Bag Filter	81	91	107	132	132	143	159	176	192	221	253	253	278	311	352	388	417	
3MX	3-Way Mix Damper Sect	146	178	213	251	251	294	376	414	506	571	806	767	848	1049	1314	1442	1546	
3MXIL	3-Way Mix Damper In line	130	152	184	263	263	306	378	445	570	640	985	985	1084	1252	1566	1694	1822	
HF	HEPA Filter	88	102	126	155	155	182	206	223	253	297	364	364	409	466	551	607	660	
CF	Carbon Filter	119	164	219	279	279	368	454	471	563	669	891	891	1060	1210	1512	1692	1838	
PSE	Pump Set Enclosure	165	174	186	200	200	212	225	236	275	287	313	313	328	382	401	420	435	
HC	Frost / LPHW / Pre / Re Heater	46	53	64	75	75	91	106	120	138	158	193	193	219	253	281	315	341	
EAHB	Electric Air Heater Battery	46	53	64	75	75	91	106	120	138	158	193	193	219	253	281	315	341	
GH	Gas Heater	84	97	107	140	140	167	177	235	246	263	290	290	300	315	465	481	493	
CC	Cooler, DX or CH.W	88	94	141	180	180	236	296	348	409	488	622	622	728	880	991	1129	1231	
SL	Standard Louvre	4	6	7	9	9	13	17	20	24	29	37	37	44	54	63	72	79	
AL	Acoustic Louvre	24	26	27	29	29	33	37	40	44	49	57	57	64	74	83	92	99	
PA	Plenum / Access	75	84	96	110	110	122	135	146	160	172	198	198	213	232	251	270	285	
AT1	Attenuator	107	123	147	174	174	212	252	287	324	375	460	460	523	612	715	819	876	
AT2	Duct Mounted Attenuator	140	161	193	229	229	279	332	378	427	495	606	606	691	808	945	1083	1158	
HUM	Humidifier	109	118	130	144	144	190	203	214	228	274	375	375	421	450	530	559	582	
BH1	Base 100mm High 1000L	6	6	6	6	6	6	10	10	10	10	15	15	15	15	15	20	20	
BH2	Base 150mm High 1000L	7	7	7	7	7	7	11	11	11	11	16	16	16	16	16	22	22	
RH	Roof Section 1000L	10	11	14	17	17	17	18	19	23	23	28	28	28	28	32	36	40	
	Floor Grid 1000W	-	-	-	-	-	-	24	24	24	34	43	43	43	43	51	58	63	
	25mm Acoustic Treatment	5	5	5	5	5	5	5	5	5	5	5	5	5	5	5	5	5	
	50mm Acoustic Treatment	10	10	10	10	10	10	10	10	10	10	10	10	10	10	10	10	10	

Water

Weight of water in coils (kg) = 5.3 x face area m<sup>2</sup> x number of rows. Cooling generally 4-6 rows, heating generally 1-2 rows.



# Fan & Control Configuration Weights kg

Dim	Size	1	2	3	4S	4	5	6	7	8	9	10S	10	11	12	13	14	15	
Fan & Control Configurations																			
ECFS	EC Fan Sect	133	147	165	241	187	314	-	-	-	-	-	-	-	-	-	-	-	-
PFS	Plug Fan Sect	140	173	191	290	212	359	483	510	545	812	1015	797	993	1042	1177	1370	1412	
TFS	Twin Fan Section	-	-	-	-	-	-	-	432	563	590	652	820	860	910	1193	1483	1743	
CP1	Control Panel Enclosure	110	122	138	161	161	182	201	234	242	268	294	294	314	338	384	410	426	
CPF1	Controls Panel Fan Sect	249	309	345	414	-	-	-	-	-	-	-	-	-	-	-	-	-	-
CPF2	Controls Panel Fan Sect	-	-	-	-	281	378	458	535	623	780	979	860	1063	1116	1175	1230	1264	
CPF3	Controls Panel Fan Sect	-	-	-	-	-	-	-	-	-	763	753	954	900	949	1237	1523	1783	

Weight of fan sections shown are with the largest fan possible for each size section. Weight will reduce when using a smaller fan or fans.

## Controls Partner

### Heat Recovery Efficiency

As part of our RAC3MX range of Air Handling Units we are able to supply our Intelligent Energy Control (IEC) system.

The IEC system is powerful, flexible, user-friendly and specifically designed to provide a complete control solution for Air Handling and Conditioning Systems.

At the heart of our IEC solution is the fully programmable IQ4 controller which is housed within an IP65 enclosure.

Further to this our IEC system will interface with many manufacturers equipment including but not limited to Mitsubishi, Daikin, Toshiba, Samsung and Panasonic and has the facility to support many protocols; these include Modbus, BACnet, LonWorks, and SNMP.

As of the 1st of June 2018 our customers who purchase the IEC system will receive a 5-year limited hardware Warranty on our IQ4 controllers and modules.

### Forward Thinking

As a controls partner we strive to maintain a position at the forefront of technology, and have developed considerable expertise in manufacturing both the hardware and software that makes up the Intelligent Energy Control system.

The greatest advantage ECE has from being able to design and manufacture the software and hardware, is that it greatly strengthens the company's ability to set the technological innovation and design standards throughout our industry.

Two of our latest IEC technological developments benefiting our customers are Economy Mode and Intelligent Frost Protection.

### Economy Mode

Economy Mode has three stages of system efficiency including economy cycle, free cooling and energy recovery.

This system can offer incredible savings to end users and reduce air handling unit motor energy consumption by up to 50%.

### Intelligent Frost Protection

Our Intelligent Frost Protection will monitor internal condition of the building during night shutdown and protect the building fabric. The units will achieve this by running for short periods every two hours (user adjustable) to read the return air temperature. If after 10 minutes of operation the return air temperature is above the non-occupied temperature set point the unit will be disabled until the next start cycle.

If any of the units read a temperature below the minimum non-occupied temperature set point, that unit will operate until the return air temperature rises above the non-occupied temperature set point.





# Air Handling Unit Construction

At ECE UK we have improved the design of our equipment over the last forty years offering a cost-effective solution including L2 Leakage Class, D1 Deflection Class, TB1 Thermal Bridging and T2 thermal Transmittance. This is complimented by achieving standards set out in ERP 2016/18 and L2 Specific Fan Power.

To further ensure structural stability, rigidity and thermal qualities BS EN 1886:2007 standard provides the means for classifying the performance of all our air handling units.

The Air Handling Unit framework is constructed from a closed aluminium box section with heavy duty injection moulded ABS black nylon knock in corner pieces. This high density and lightweight structure ensures a strong and rigid framework for the Air Handling Unit.

Depending upon the project requirements panels can be either 25mm or 50mm thick. Panels are constructed from a galvanised sheet steel inner skin with a plastisol coated or galvanised sheet steel outer skin with mineral wool insulation sandwiched between the sheets. Our standard plastisol colour is Goosewing Grey RAL10A05, other colours are available on request.

Our standard mineral wool insulation has a density of 100kg/m<sup>3</sup>.

As standard each complete unit or modular section would be factory assembled on a full perimeter base to ensure full structural stability.

All externally mounted units would be fully sealed and completed with an overhanging pitched roof to prevent water ingress.

Depending upon site access all of our Air Handling Units can be supplied as modular sections, component form or fully assembled on a single piece base frame and still conform to the standards set out above.

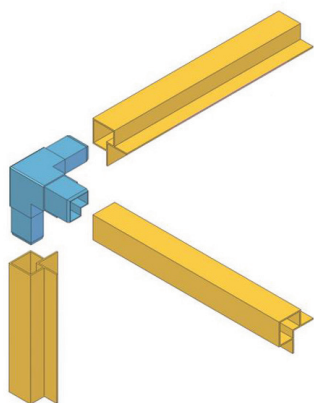
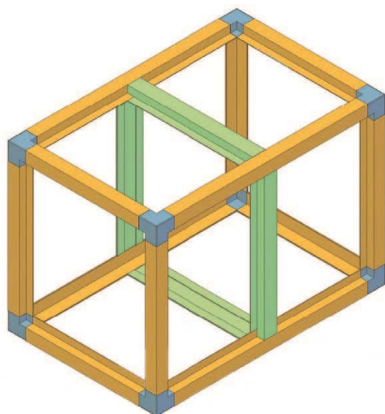

# Asset Information

This AHU mounted web based portal augments our customer experience by providing you with all your BIM Level 2 files for your job specific, bespoke, Air Handling Unit as defined at the design stage.



**Asset Information**

Either show the QR code to your code reader app of choice, or visit <https://asset.eceuk.com/> and enter the reference number below

**682 528 185 640 707 446**



Pharaoh House, Arncliffe Close, Medway City Estate,  
Rochester, Kent ME2 4QW

[www.eceuk.com](http://www.eceuk.com) e mail : [aftersales@eceuk.com](mailto:aftersales@eceuk.com)

This allows building maintenance teams, consultants and contractors unique access to one of the most productive portals available.

Here is just some of the great features that our portal offers:

- 3D models to go into your Building Management System, such as Revit (.step, .sat, .ifc, .dwg (3D), etc).
- 3D models that can be interacted with in real-time using augmented reality devices (such as a Microsoft HoloLens).
- 2D Certified Drawings (.dwg for loading into AutoCAD / DraftSight and .pdf for opening on any device, anywhere).
- Consumables Information (such as Filters, Motors, Sensors and Actuators).
- Single click Basket for consumables with Anything Air Handling, our Spares & Parts shop [www.aahuk.com](http://www.aahuk.com).
- Controls Documents (if your AHU has one of our controls package).
- Refrigeration Unit Information.
- Installation, Operation and Maintenance Manual.
- Recycling Manual.

All you need to access this information is a unique reference number and an email address. To make it really easy each of our units now come with an Asset Information plate allowing you on-premises access to all the information from your mobile device.

**TRY IT! Scan the QR and enter the code**



## Did you know...?

- on a DX system the indoor coil is mounted internal to the AHU and outdoor coil is the condensing unit.
- when matching indoor to outdoor coils HEX volume, Air Volume, Coil Capacity and Coil Circuitry should match.
- at peak times during summer and winter, outdoor coil capacities on DX systems can reduce by up to 20%. Dependent on ambient temperatures.
- minimum air on temperature in heating mode for a DX system indoor coil is 10°C.
- swings in temperature are often caused by DX run on times and single circuit DX systems supplying small areas. This is more prevalent in small areas and with air volumes below 1.0 m<sup>3</sup>/s. Twin circuits will often reduce the risk of this happening.
- by supplying twin circuits you reduce the risk of cold air being pumped into the area served when one circuit is in defrost.
- some DX units have eleven capacity steps whereas others may only have five.
- the term "vertical unit" has the same meaning as double stacking and or piggy back arrangement.
- if you're concerned about the equipment access route, ECE can offer a free site survey.
- ECE can offer a long reach HIAB vehicle with a reach of 27 meters holding one tonne.
- if ECE supply the AHU, Controls and DX equipment the AHU warranty is extended to two years.
- ECE offer a 5 year warranty on its iQ range of controllers.
- ECE offer a 5 year warranty on its DX units.
- ErP requires supply systems to have minimum ePM 2.5 50% grade filtration.
- Location, Internal or External.
- Delivery in modules or packaged in one piece (dimensions limits apply).
- Units also available "Dry Built" for site off load, dismantle, carry through, re-assemble, join and seal.
- Units also available in component form for site offload, carry through, re-assemble, join and seal.
- Fewer pressure producing components reduces the overall energy consumption thus reducing carbon footprint, SFP and running costs of the AHU.
- AHU cooler and heater duties will incorporate coolth and heat recovery capacity and reduce the size of the indirect or direct heating and cooling equipment. This will reduce the indirect or direct heating and cooling equipment cost to the client by up to 20%.
- AHU's can include EC Fans (IE4 Motors) to give the highest possible efficiency and the lowest life cycle cost.
- By removing the frost coil this increases heat recovery efficiency as the delta t between return air and fresh air is greater. Thus more energy is available for recovery.

### ECE UK Ltd.

**T** +44 (0)1634729690  
**E** sales@eceuk.com  
**W** www.eceuk.com  
**A** Pharaoh House, Arnolde  
Close, Rochester, Kent,  
ME2 4QW

