

# Plate Exchanger Aluminium PXA

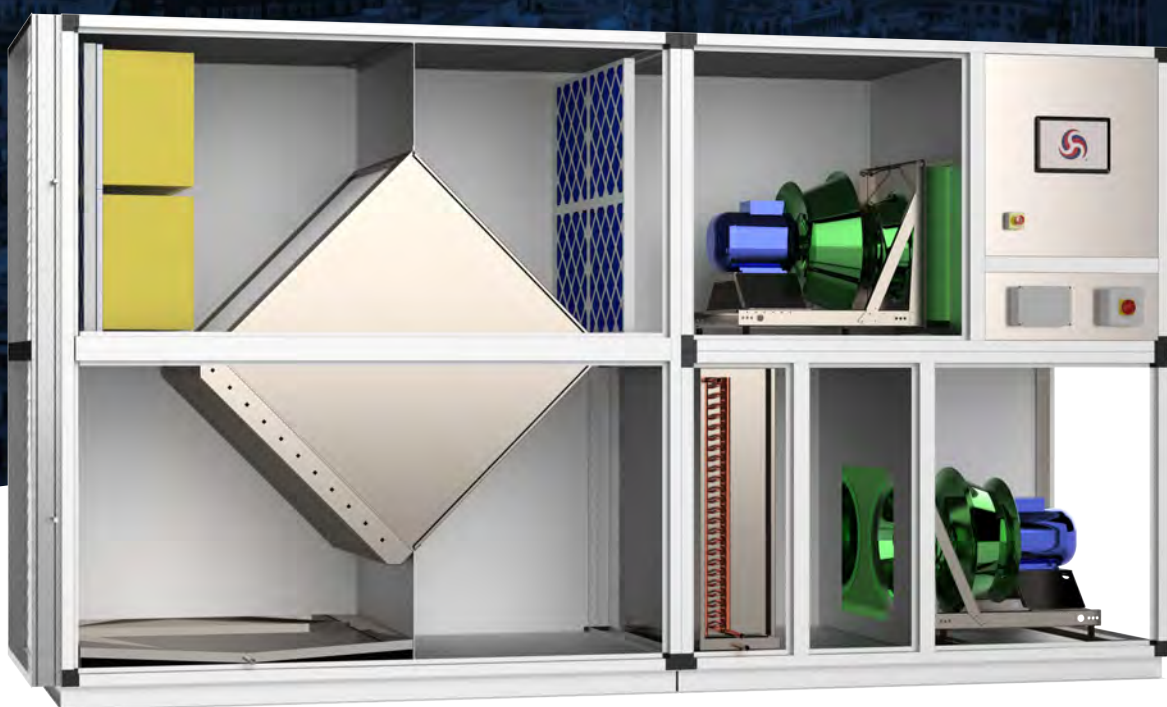

Selection Data

# Company Profile

ECE UK Ltd is a privately owned company that was established in 1979 by the existing directors and shareholders. We operate from our 4,000m<sup>2</sup> manufacturing facility in Rochester where we produce air handling / conditioning units and controls of the highest quality; which is reflected by our level of customer retention.

With forty years of experience, we are a leader in the field of air handling, conditioning and control systems.

Our experienced and knowledgeable members of staff have obtained qualifications from HNC to Master's Degree. To compliment this we provide an in-house and external training programme. We are committed to working in partnership with Consultants, Contractors and End-Users, providing added value through technical innovation, service excellence and the ability to provide energy efficient solutions.

ECE UK offers a wide range of Products and Services that complement our PXA range of Air Handling Units including:

## Air Conditioning

Heat pump units and interconnecting refrigeration pipe work.

## Controls

Trend Control systems either mounted internal to AHU or remote.

## Site Wiring

Our qualified engineers would install all interconnecting control wiring external to the air handling unit along agreed routes.

## Plant Movement

Refurbishment, Removal, and Installation of Air Handling Units, Air Conditioning Units and Controls.

## After Sales

Warranty assistance and troubleshooting of site issues for Air Handling Units, Air Conditioning Units and Control Systems.

## Service & Maintenance

Platinum, Gold and Silver maintenance packages for Air Handling Units, Air Conditioning Units and Control Systems.

By providing the many Products and Services in one place we can offer you the convenience of obtaining all your ventilation, air conditioning and control requirements from one manufacturer.



# PXA Explained

## Heat Recovery Efficiency

Dependent on the right conditions, heat recovery efficiencies can reach 80%. The correct efficiency is a subjective decision and depends on the economic calculation and written guidelines, i.e. Eco-design Commission Regulation (EU) No 1253/2014, on operating data such as energy prices, useful life, running times, temperatures, maintenance costs and interest rates. With regard to (EU) No 1253/2014, profitability and environmental protection the heat recovery efficiency should be no less than 73%.

## Operation

Plate heat exchanger air handlers are configured either in a side by side or double stacked configuration. The warm extract air and the cool fresh air, separated by thin plates, pass each other in cross flow. No mixing of the two air streams takes place, therefore the transmission of dirt, odours, moisture, bacteria etc. is near on impossible. Heat is transmitted from extract air to fresh air purely by conduction as a result of the temperature difference between the two air streams. The warm extract air is cooled down; the cool fresh air is heated.

From the process, the specific heat output capacity depends on the temperature difference between the two air streams. Hence the plate heat exchanger is suitable for heat as well as coolth recovery. i.e. for winter and summer conditions.

## Intelligent Energy Control

Either our Intelligent Energy Control system or the clients BMS may monitor the return air quality, energy efficiency available to recover or CO2 concentration for optimum energy efficiency whilst maintaining desired fresh air requirements. Additionally, when outside air conditions are such, typically mid-season weather conditions, it may be that ambient temperatures are suitable for free cooling purposes.

Our complete range of AHUs can be tailor made to suit all customer requirements including direct & indirect heating, cooling, heat pumps, controls & refrigeration.



## Basic Principles

ECE UK plate heat exchangers operate within the guidelines for heat recovery (e.g. Eurovent 10, VDI 2071) as recuperators with joint faces (category 1). The heat releasing and heat absorbing air streams pass along the joint face, through which the heat is directly transmitted. Supply and exhaust air must therefore be brought together and flow through the heat exchanger.

## Condensation

ECE UK plate heat exchangers can use part of the latent heat of moist extract air. At low outside temperatures, when there is a high heat demand, the extract air is cooled down to such a degree that the saturation temperature is reached and condensation is formed. Thus the latent heat of evaporation is released. This reduces further cooling of the extract air, i.e. the temperature difference between the air streams in the plate heat exchanger is greater than when there is no condensation. Also the heat transfer is better; consequently the temperature efficiency is raised significantly.

Condensation in the extract air reduces the free area of the airway and is responsible for an increase in pressure drop. Therefore it is important that the condensation can drain away. This depends mainly on the fitting position of the heat exchangers and on the form of the plates.

## Temperature Efficiency

In principle, nearly any temperature efficiency can be achieved if sized and designed to suit. For instance, the efficiency can be substantially raised by installing two exchangers in series.

However, this increase in efficiency:

- either is at the expense of a high pressure drop,
- or at the expense of a large space requirement,
- and an increase in cost.

## Performance Control

ECE UK plate heat exchanger operates as a temperature moderator between the two air streams. The direction of the heat transmission is of no consequence, i.e. depending on the temperature difference between extract and fresh air, either heat recovery or cool recovery takes place.

With the ECE plate heat exchanger the performance control through change of the mass flow ratio is simply and economically accomplished with the bypass.

## Bypass In The Supply Air Stream

Depending on damper position, between 0 % and 100 % of the fresh air passes through the bypass. The extract air always flows through the heat exchanger and is cooled according to the fresh air flow rate. With this arrangement the cooling of the extract air and thus freezing can be avoided.

## Bypass In The Extract Air Stream

Between 0 % and 100 % of the extract air passes through the bypass. The fresh air always passes through the plate heat exchanger. This arrangement is recommended when the extract air is very dirty, as during summer operation the extract air does not pass through the plate heat exchanger.

## Plate Structure

### Exchanger Package in Designs S & F

The exchanger package consists of specially formed aluminium plates. Their profile with V-shaped spacing ribs is an optimum design resulting from detailed tests for temperature efficiency, pressure drop and rigidity.



The special profiles of our plates are the result of extensive tests and measurements (design S shown here).

### Exchanger Package In Design F

The exchanger package consists of specially shaped aluminium or stainless steel plates. Their profile with V-shaped spacing ribs is an optimum design resulting from detailed tests for temperature efficiency, pressure drop and rigidity.

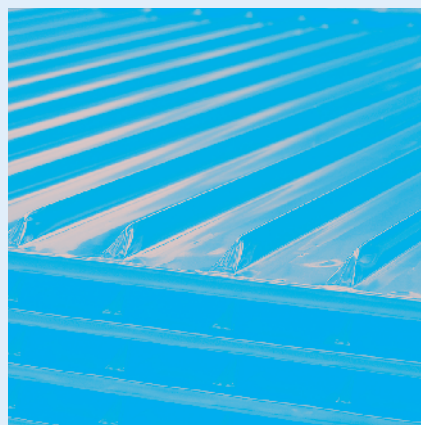

Thanks to folded plate connections the exchanger packages are tight and rigid (design F shown here).



## Leakage Test

Plate heat exchangers are not 100% leak-proof unless special measures are taken. Yet by additional sealing, ECE UK can guarantee that the exchanger is delivered watertight in the tested installation position.

### Leakage test 4P

Both the main air flow and bypass air flows are sealed off for leakage testing purposes.

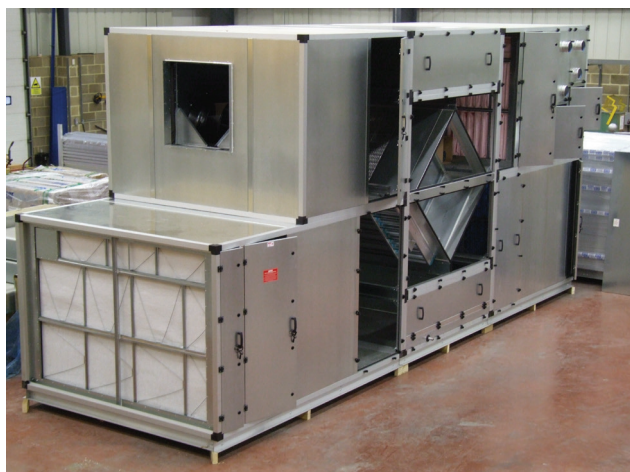
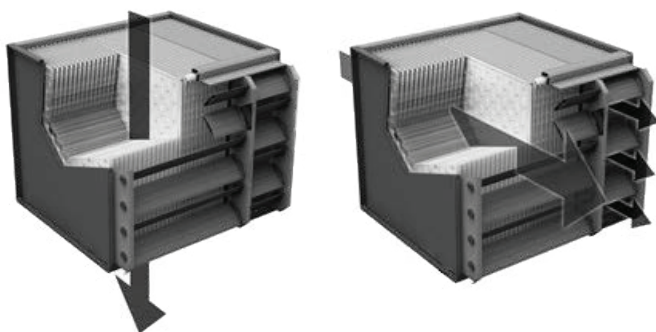

## Specification Texts

### Design S

ECE UK cross-flow plate heat exchanger for heat recovery, consisting of exchanger package and casing: The exchanger package consists of aluminium plates with pressed-in spacers; condensate drainage is possible in every direction, depending on the installation position.

The plates are connected by a fold, which gives a several fold material thickness at air entry and exit. The corners of the exchanger package are sealed into especially rigid aluminium extrusions in the casing with a sealing compound. The side walls of Aluzinc sheet steel are bolted tightly to these extrusions.

All performance data is Eurovent-certified by Eurovent and RLT (TÜV Süd). Dry temperature efficiencies up to 80 % can be achieved. The exchangers are resistant to up to 2500 Pa pressure difference between the air streams.

### Design SV

Series SV (standard): Aluminium plates, extruded aluminium sections and Aluzinc sheet steel; silicone-free; resistant to temperatures up to 90°C.

### Design F

ECE UK cross-flow plate heat exchanger for heat recovery, consisting of exchanger package and casing: The exchanger package consists of aluminium plates with pressed-in spacers; condensate drainage is possible in every direction, depending on the installation position.

The plates are connected by a fold, which gives a several fold material thickness at air entry and exit. The corners of the exchanger package are sealed into especially rigid aluminium extrusions in the casing with a sealing compound. The side walls of Aluzinc sheet steel are bolted tightly to these extrusions.

All performance data is Eurovent-certified by Eurovent and RLT (TÜV Süd). Dry temperature efficiencies up to 80% can be achieved. The exchangers are resistant to up to 2500 Pa pressure difference between the air streams.

### Design FV

Series FV (standard): Aluminium plates, extruded aluminium sections and Aluzinc sheet steel; silicone-free; resistant to temperatures up to 100°C.

## Control Damper

To regulate the air flow through the bypass or the exchanger, opposed control dampers are necessary.

The dampers have the following special features:

- Damper's air leakage flow rate complies with class 2, BS EN 1751.
- Driving plastic gear wheels are fitted in the middle, i.e. between the bypass and the heat exchanger.
- Gear wheels are protected from the air stream.
- Blades consist of rigid profiles and are therefore particularly tight.
- Maximum torque allowed is 20 Nm.
- Damper shaft can be installed at any blade on either side of the damper.

To ensure an optimum torque transfer installation at a blade in the middle of the damper is recommended.

# Popular PXA Configurations

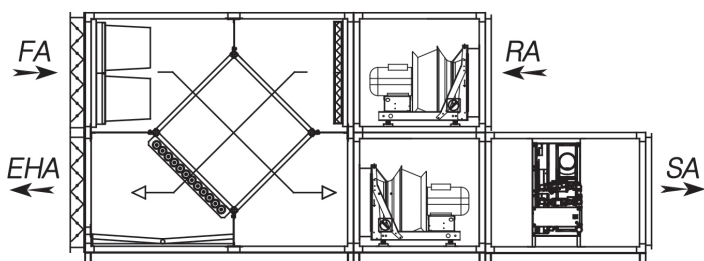
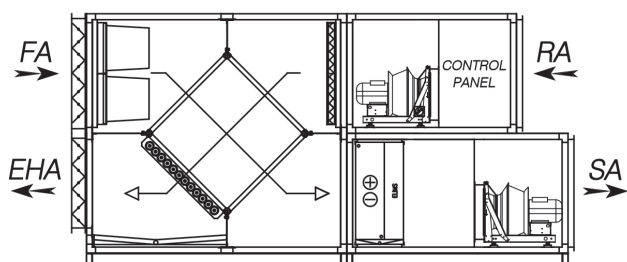
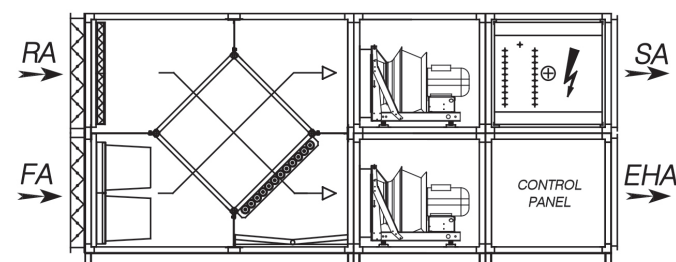
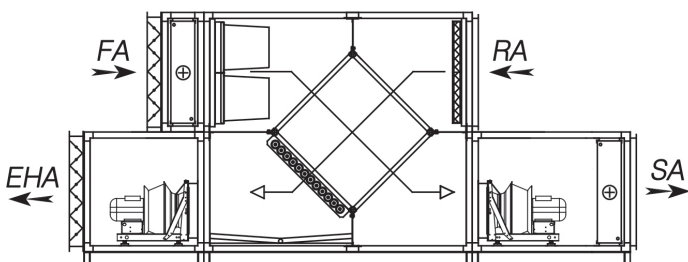
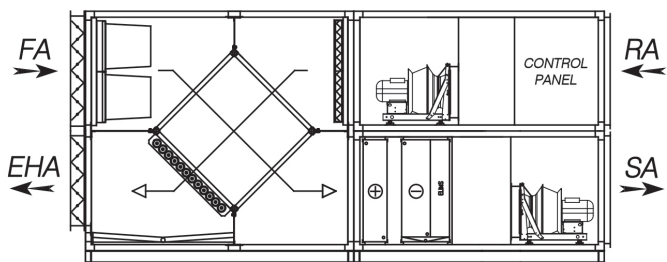

## Selection Information

- Dimensions on page 8 & 9 are for roughing in only.
- To keep specific fan power (SFP) within ERP 2016 and L2 requirements, the following should be adhered too:
  - ~ For AHU's with external system resistance <200Pa for both supply and extract systems, keep the face velocity between 2.5 and 3.0 m/s.
  - ~ For AHU's with external system resistance between 200Pa – 400Pa for both supply and extract systems, keep the face velocity between 2.0 and 2.5 m/s and include 635mm long bag filters.
- Contact technical sales for specials if unit sizes are difficult to accommodate.
- Fan total pressures from 100Pa to 1500Pa (including AHU internal losses).
- Maximum external pressure available i.e. AHU inlet negative pressures plus AHU discharge positive pressure = fan static pressure less AHU internal component resistances for both extract and supply AHU's.
- Height and width dimensions in tables are the AHU frame outside dimensions. Add base dimension, also add roof dimension (RH) if unit is external.
- Component length dimensions are space that each internal component occupies.
- Maximum overall AHU length unlimited. (Maximum single piece size subject to transport restrictions).
- Frame inlet connections generally 30mm up to size 5 and 50mm size 6 and above, around frame perimeter, undrilled.
- Inlet connections can be mezz flanges 30mm and 40mm as required.
- Outlet fan connections from unit – see dimension tables.
- If fresh air intake is at the bottom of the AHU and the supply sits at the top of the AHU the extract section at the bottom of the AHU will need blank plenums to support the supply.
- Individual section lengths including components like coils, attenuators or filters can range from 300mm to 2400mm. Each individual component does not have to sit within its own section.
- It is possible to have up to 4 stages of filtration on both the supply and extract air streams.
- "X" dimension will only be required if the supply or extract fan is downstream of a full face component, other than the plate heat exchanger.
- Due to ERP 2016, level of filtration to always be F7 grade supply and M5 grade on extract.
- Gas heaters should be the last component in supply air configuration.
- Due to height restrictions, floor grid available from unit sizes 6 to 15 only. No need for floor grid if walk in access is not available.

# Velocity Chart

(Vc)m/s	VOLUME m <sup>3</sup> /s AT COIL FACE VELOCITIES (Vc) m/s	Unit Size																
		1	2	3	4S	4	5	6	7	8	9	10S	10	11	12	13	14	15
1.75		0.36	0.52	0.75	1.09	1.09	1.52	2.16	2.55	3.14	3.99	4.85	5.33	6.47	7.99	9.47	10.98	12.10
2.0		0.42	0.61	0.87	1.2	1.2	1.85	2.54	2.98	3.65	4.64	5.6	6.18	7.51	9.5	10.82	12.53	13.8
2.25		0.47	0.68	0.97	1.35	1.35	2.09	2.86	3.35	4.12	5.22	6.3	6.95	8.44	10.69	12.17	14.09	15.53
2.5		0.52	0.76	1.08	1.5	1.5	2.32	3.17	3.73	4.56	5.81	7.1	7.73	9.39	11.88	13.53	15.66	17.26
2.75		0.58	0.83	1.19	1.65	1.65	2.55	3.48	4.1	5.02	6.39	7.7	8.5	10.32	13.07	14.88	17.23	18.99
3.0		0.63	0.91	1.3	1.8	1.8	2.78	3.8	4.47	5.48	6.97	8.4	9.28	11.27	14.25	16.23	18.79	20.71
3.25		0.67	0.99	1.41	1.95	1.95	3.01	4.12	4.85	5.94	7.56	9.1	10.05	12.2	15.44	17.58	20.36	22.44

\*Please select unit size from the above table using the velocity first, then to the nearest m<sup>3</sup>/s value to your required air volume.  
 \*\*Reduce Velocity, Increase unit size is the preferred final selection.

## Base Models

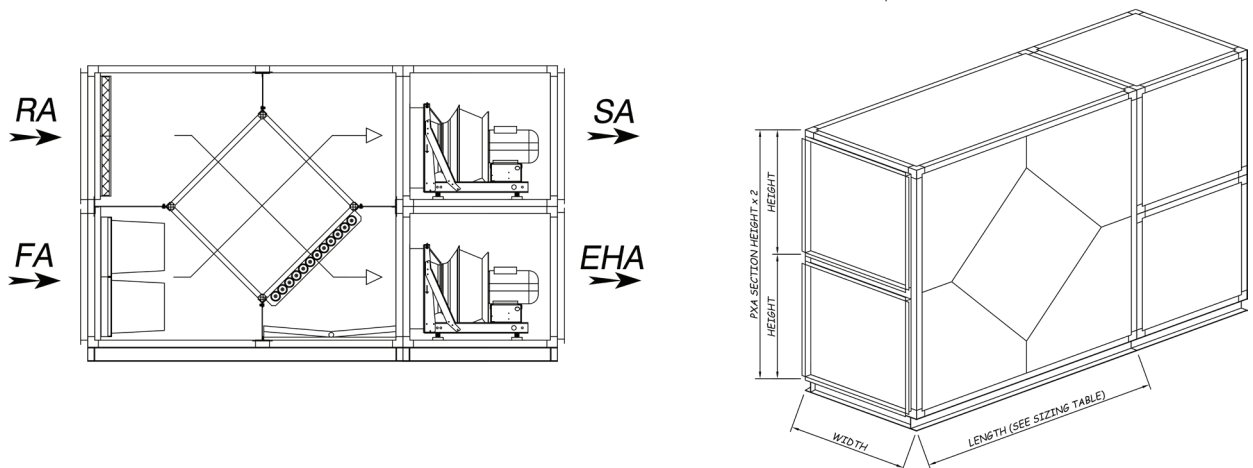
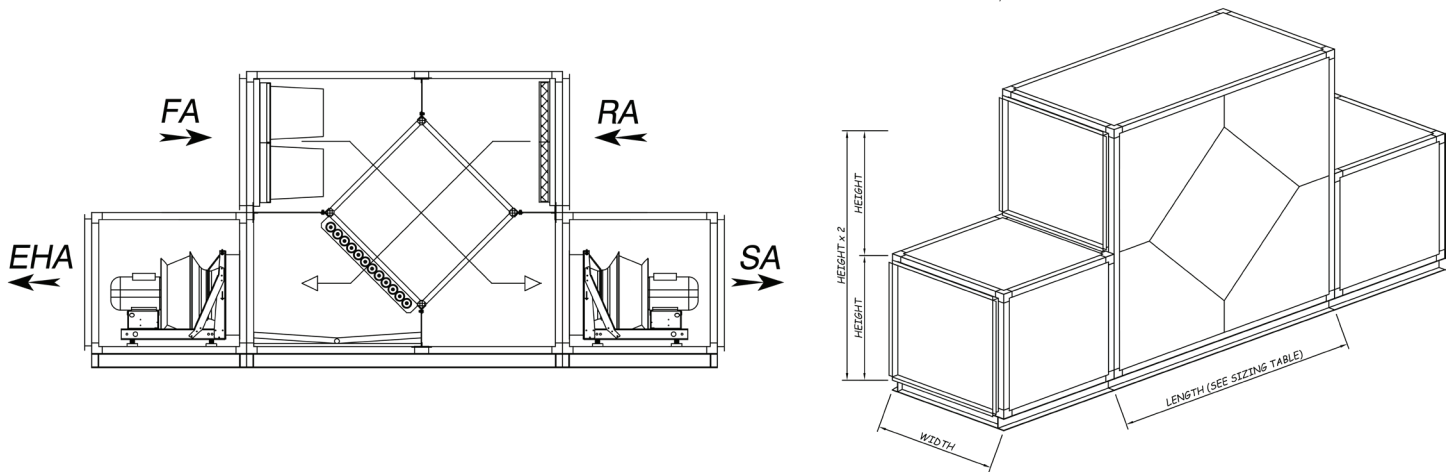
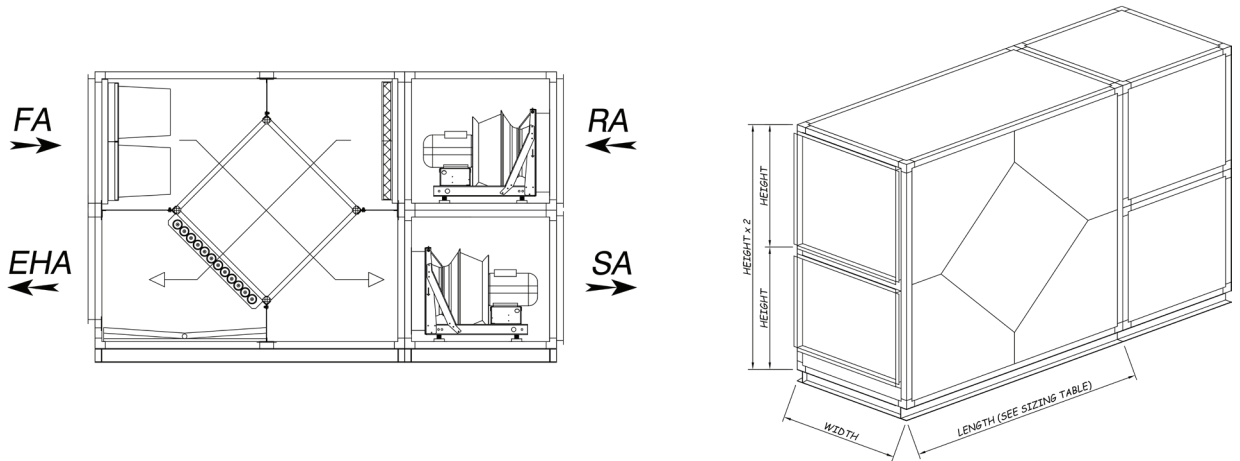

# AHU Components

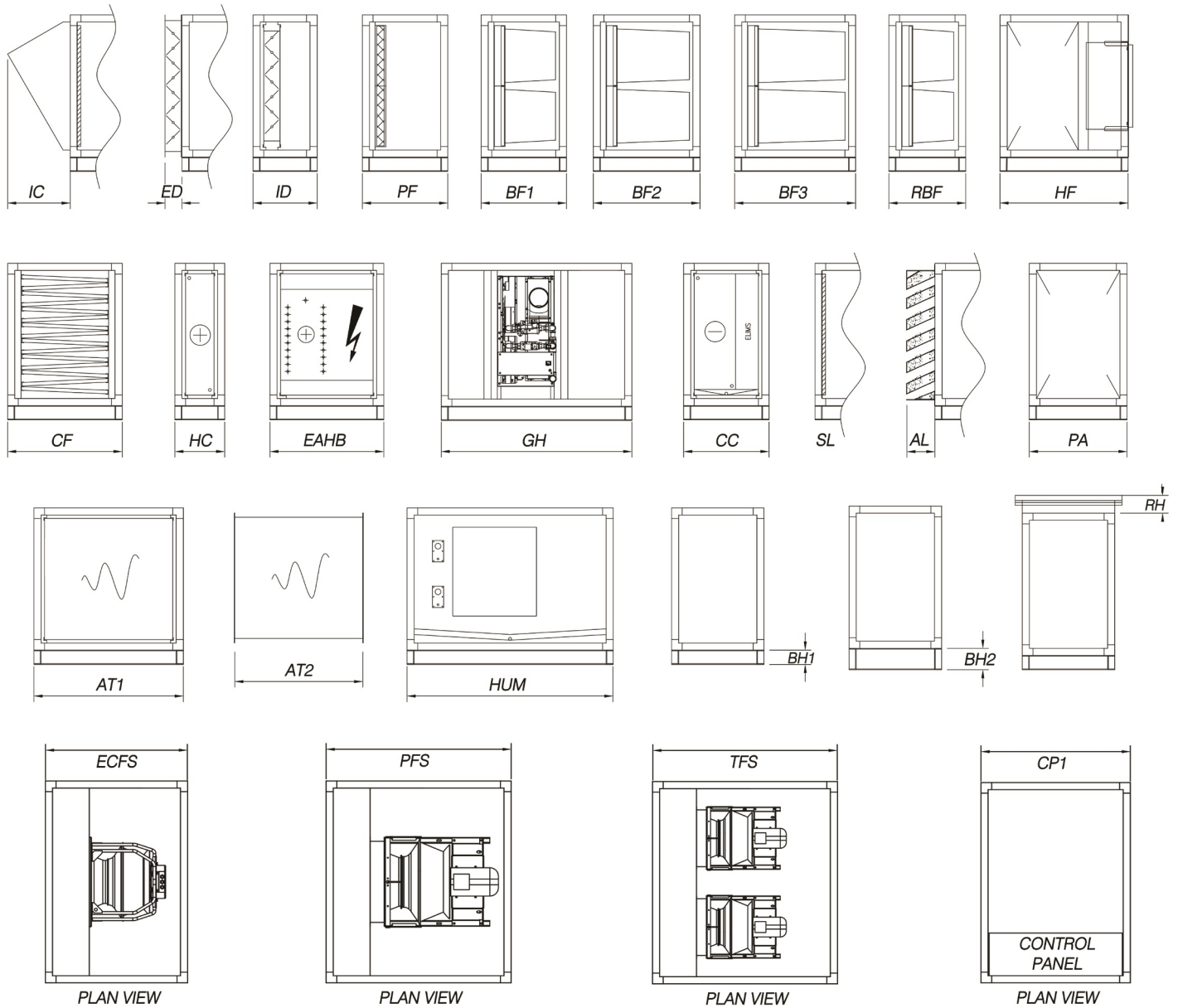

# Fan & Control Configurations

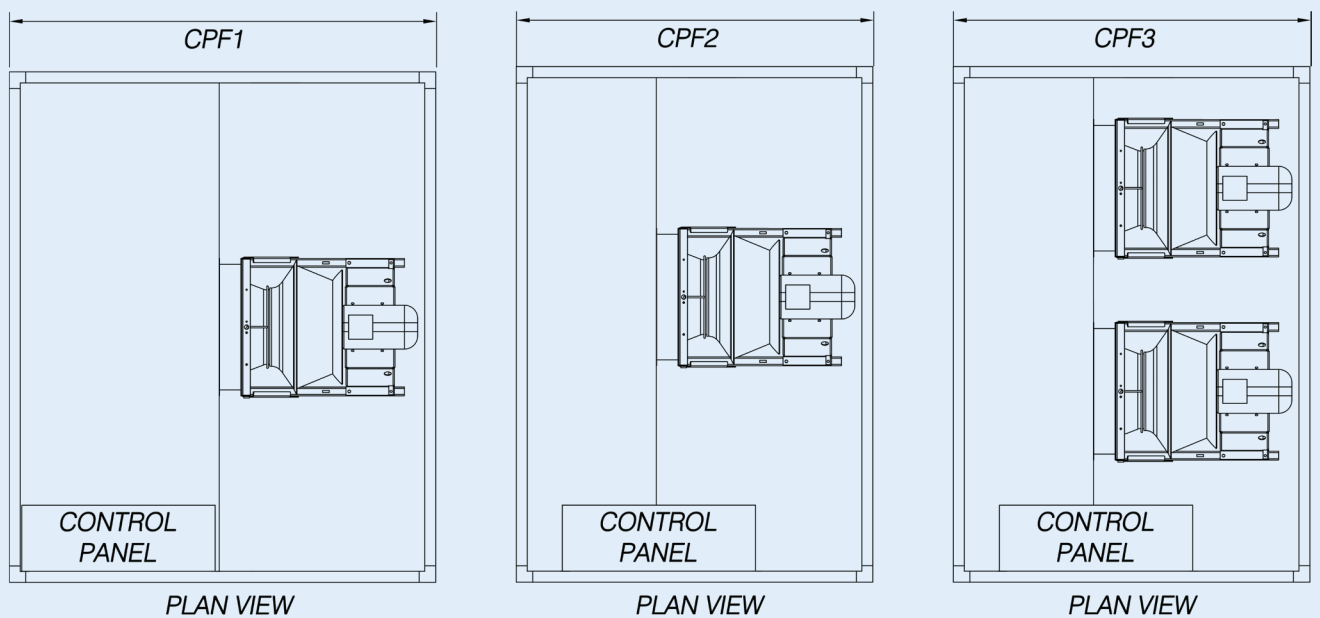

# Dimension Table

Dim	Size	1	2	3	4S	4	5	6	7	8	9	10S	10	11	12	13	14	15	
Additional Components Height & Width																			
H	Height 25mm Panels	610	730	730	1020	730	1020	1360	1360	1360	1670	1970	1670	1970	2400	2400	2400	2400	
W	Width 25mm Panels	690	780	1010	1010	1310	1310	1360	1560	1860	1860	1860	2400	2400	2400	2800	3200	3500	
H	Height 50mm Panels	650	770	770	1060	770	1060	1360	1360	1360	1670	1970	1670	1970	2400	2400	2400	2400	
W	Width 50mm Panels	730	820	1050	1050	1350	1350	1410	1610	1910	1910	1910	2450	2450	2450	2850	3250	3550	
Double Stacked PXA Height																			
-	Double Stacked PXA Height 25mm	1220	1460	1460	2040	1460	2040	2720	2720	2720	3340	3940	3340	3940	4800	4800	4800	4800	
-	Double Stacked PXA Height 50mm	1300	1540	1540	2120	1540	2120	2720	2720	2720	3340	3940	3340	3940	4800	4800	4800	4800	
Side by Side PXA Height																			
-	Side by Side PXA Height 25mm	610	730	730	1020	730	1020	1360	1360	1360	1670	1970	1670	1970	2400	2400	2400	2400	
-	Side by Side PXA Height 50mm	650	770	770	1060	770	1060	1360	1360	1360	1670	1970	1670	1970	2400	2400	2400	2400	
Additional Component Lengths																			
PXA	Plate Heat Exchanger	1800	1800	1800	2000	2000	2000	2400	2400	2400	2400	2700	2700	2700	3000	3000	3000	3000	
IC	Inlet Cowl	200	250	250	250	250	400	550	550	550	700	700	700	700	700	700	700	700	
ED	External Damper	120	120	120	120	120	120	120	120	120	120	120	120	120	120	120	120	120	
ID	Internal Damper	450	450	450	450	450	450	450	450	450	450	450	450	450	450	450	450	450	
PF	Panel Filter	300	300	300	300	300	300	300	300	300	300	300	300	300	300	300	300	300	
BF1	Bag 380 - BS EN 16890	600	600	600	600	600	600	600	600	600	600	600	600	600	600	600	600	600	
BF2	Bag 535 - BS EN 16890	750	750	750	750	750	750	750	750	750	750	750	750	750	750	750	750	750	
BF3	Bag 635 - BS EN 16890	850	850	850	850	850	850	850	850	850	850	850	850	850	850	850	850	850	
RBF	Rigid Bag Filter	550	550	550	550	550	550	550	550	550	550	550	550	550	550	550	550	550	
HF	HEPA Filter	900	900	900	900	900	900	900	900	900	900	900	900	900	900	900	900	900	
CF	Carbon Filter	900	900	900	900	900	900	900	900	900	900	900	900	900	900	900	900	900	
HC	Frost / LPHW / Pre / Re Heater	250	250	250	250	250	250	250	250	250	250	250	250	250	250	250	250	250	
EAHB	Electric Air Heater Battery	900	900	900	900	900	900	900	900	900	900	900	900	900	900	900	900	900	
GH	Gas Heater	1200	1200	1200	1200	1200	1200	1600	1600	1600	1600	1600	1600	1600	1600	1600	1600	1600	
CC	Cooler, DX or CH.W	550	550	550	550	550	550	550	550	550	550	550	550	550	550	550	550	550	
SL	Standard Louvre	0	0	0	0	0	0	0	0	0	0	0	0	0	0	0	0	0	
AL	Acoustic Louvre	300	300	300	300	300	300	300	300	300	300	300	300	300	300	300	300	300	
PA	Plenum / Access	600	600	600	600	600	600	600	600	600	600	600	600	600	600	600	600	600	
AT1	Attenuator	1050	1050	1050	1350	1350	1350	1350	1350	1350	1350	1650	1650	1650	1650	1650	1650	1650	
AT2	Duct Mounted Attenuator	900	900	900	1200	1200	1200	1200	1200	1200	1200	1500	1500	1500	1500	1500	1500	1500	
HUM	Humidifier	1200	1200	1200	1200	1200	1200	1200	1600	1600	1600	1600	1600	1600	1600	1600	1600	1600	
BH1	Base Height	100	100	100	100	100	100	100	100	100	100	100	100	100	100	100	100	100	
BH2	Base Height	150	150	150	150	150	150	150	150	150	150	150	150	150	150	150	150	150	
RH	Roof Height	125	125	125	125	125	125	125	125	125	125	125	125	125	125	125	125	125	

Dimensions are for roughing in only



# Dimension Table

Dim	Size	1	2	3	4S	4	5	6	7	8	9	10S	10	11	12	13	14	15	
Fan & Control Configurations																			
ECFS	EC Fan Sect	900	900	900	1200	900	1400	-	-	-	-	-	-	-	-	-	-	-	-
PFS	Plug Fan Sect	900	900	900	1200	900	1300	1500	1500	1500	1900	1900	1600	1600	1600	1800	2100	2100	2100
TFS	Twin Fan Section	-	-	-	-	-	-	-	1200	1400	1400	1400	1600	1600	1600	1800	2100	2100	2100
CP1	Control Panel Enclosure	800	800	800	800	800	800	800	800	800	800	800	800	800	800	800	800	800	800
CPF1	Controls Panel Fan Sect	1700	1800	1800	1800	-	-	-	-	-	-	-	-	-	-	-	-	-	-
CPF2	Controls Panel Fan Sect	-	-	-	-	1200	1300	1300	1500	1700	1700	1700	1700	1700	1700	1700	1700	1700	1700
CPF3	Controls Panel Fan Sect	-	-	-	-	-	-	-	-	-	1900	1600	1900	1600	1600	1800	2100	2100	2100

# AHU Component Dry Weights kg

Dim	Size	1	2	3	4S	4	5	6	7	8	9	10S	10	11	12	13	14	15	
Additional Components																			
IC	Inlet Cowl	4	6	7	9	9	13	17	20	24	29	37	37	44	54	63	72	79	79
ED	External Damper	16	20	23	29	29	37	45	51	62	76	104	104	120	172	196	220	240	240
ID	Internal Damper	50	58	66	78	78	92	105	116	134	153	193	193	215	276	308	341	368	368
PF	Panel Filter	32	38	46	51	51	57	63	77	84	91	111	111	126	142	189	211	227	227
BF1	Bag 380 - BS EN 16890	80	90	106	131	131	142	158	175	191	220	252	252	277	310	351	387	416	416
BF2	Bag 535 - BS EN 16890	98	110	130	160	160	173	193	214	233	268	307	307	338	378	428	472	507	507
BF3	Bag 635 - BS EN 16890	108	120	142	176	176	190	211	235	256	294	338	338	371	416	470	518	557	557
RBF	Rigid Bag Filter	81	91	107	132	132	143	159	176	192	221	253	253	278	311	352	388	417	417
HF	HEPA Filter	88	102	126	155	155	182	206	223	253	297	364	364	409	466	551	607	660	660
CF	Carbon Filter	119	164	219	279	279	368	454	471	563	669	891	891	1060	1210	1512	1692	1838	1838
PXA	Plate Heat Exchanger	416	469	538	669	669	812	1069	1167	1273	1506	1851	1851	1960	2222	2336	2450	2540	2540
HC	Frost / LPHW / Pre / Re Heater	46	53	64	75	75	91	106	120	138	158	193	193	219	253	281	315	341	341
EHAB	Electric Air Heater Battery	46	53	64	75	75	91	106	120	138	158	193	193	219	253	281	315	341	341
GH	Gas Heater	84	97	107	140	140	167	177	235	246	263	290	290	300	315	465	481	493	493
CC	Cooler, DX or CH.W	88	94	141	180	180	236	296	348	409	488	622	622	728	880	991	1129	1231	1231
SL	Standard Louvre	4	6	7	9	9	13	17	20	24	29	37	37	44	54	63	72	79	79
AL	Acoustic Louvre	24	26	27	29	29	33	37	40	44	49	57	57	64	74	83	92	99	99
PA	Plenum/Access	75	84	96	110	110	122	135	146	160	172	198	198	213	232	251	270	285	285
AT1	Attenuator	107	123	147	174	174	212	252	287	324	375	460	460	523	612	715	819	876	876
AT2	Duct Mounted Attenuator	140	161	193	229	229	279	332	378	427	495	606	606	691	808	945	1083	1158	1158
HUM	Humidifier	109	118	130	144	144	190	203	214	228	274	375	375	421	450	530	559	582	582
BH1	Base 100mm High 1000L	6	6	6	6	6	6	10	10	10	10	15	15	15	15	15	20	20	20
BH2	Base 150mm High 1000L	7	7	7	7	7	7	11	11	11	11	16	16	16	16	16	22	22	22
RH	Roof Section 1000L	10	11	14	17	17	17	18	19	23	23	28	28	28	28	32	36	40	40
	Floor Grid 1000W	-	-	-	-	-	-	24	-	24	34	43	43	43	43	51	58	63	63
	25mm Acoustic Treatment	5	5	5	5	5	5	5	5	5	5	5	5	5	5	5	5	5	5
	50mm Acoustic Treatment	10	10	10	10	10	10	10	10	10	10	10	10	10	10	10	10	10	10

**Water** Weight of water in coils (kg) = 5.3 x face area m<sup>2</sup> x number of rows. Cooling generally 4-6 rows, heating generally 1-2 rows.

# Fan & Control Configuration Weights kg

Dim	Size	1	2	3	4S	4	5	6	7	8	9	10S	10	11	12	13	14	15	
Fan & Control Configurations																			
ECFS	EC Fan Sect	133	147	165	241	187	314	-	-	-	-	-	-	-	-	-	-	-	-
PFS	Plug Fan Sect	140	173	191	290	212	359	483	510	545	812	1015	797	993	1042	1177	1370	1412	
TFS	Twin Fan Section	-	-	-	-	-	-	-	432	563	590	652	820	860	910	1193	1483	1743	
CP1	Control Panel Enclosure	110	122	138	161	161	182	201	234	242	268	294	294	314	338	384	410	426	
CPF1	Controls Panel Fan Sect	249	309	345	414	-	-	-	-	-	-	-	-	-	-	-	-	-	-
CPF2	Controls Panel Fan Sect	-	-	-	-	281	378	458	535	623	780	979	860	1063	1116	1175	1230	1264	
CPF3	Controls Panel Fan Sect	-	-	-	-	-	-	-	-	-	763	753	954	900	949	1237	1523	1783	

Weight of fan sections shown are with the largest fan possible for each size section. Weight will reduce when using a smaller fan or fans.

## Controls Partner

### Heat Recovery Efficiency

As part of our PXA range of Air Handling Units we are able to supply our Intelligent Energy Control (IEC) system.

The IEC system is powerful, flexible, user-friendly and specifically designed to provide a complete control solution for Air Handling and Conditioning Systems.

At the heart of our IEC solution is the fully programmable IQ4 controller which is housed within an IP65 enclosure.

Further to this our IEC system will interface with many manufacturers equipment including but not limited to Mitsubishi, Daikin, Toshiba, Samsung and Panasonic and has the facility to support many protocols; these include Modbus, BACnet, LonWorks, and SNMP.

As of the 1st of June 2018 our customers who purchase the IEC system will receive a 5-year limited hardware Warranty on our IQ4 controllers and modules.

### Forward Thinking

As a controls partner we strive to maintain a position at the forefront of technology, and have developed considerable expertise in manufacturing both the hardware and software that makes up the Intelligent Energy Control system.

The greatest advantage ECE has from being able to design and manufacture the software and hardware, is that it greatly strengthens the company's ability to set the technological innovation and design standards throughout our industry.

Two of our latest IEC technological developments benefiting our customers are Economy Mode and Intelligent Frost Protection.

### Economy Mode

Economy Mode has three stages of system efficiency including economy cycle, free cooling and energy recovery.

This system can offer incredible savings to end users and reduce air handling unit motor energy consumption by up to 50%.

### Intelligent Frost Protection

Our Intelligent Frost Protection will monitor internal condition of the building during night shutdown and protect the building fabric. The units will achieve this by running for short periods every two hours (user adjustable) to read the return air temperature. If after 10 minutes of operation the return air temperature is above the non-occupied temperature set point the unit will be disabled until the next start cycle.

If any of the units read a temperature below the minimum non-occupied temperature set point, that unit will operate until the return air temperature rises above the non-occupied temperature set point.



# Air Handling Unit Construction

At ECE UK we have improved the design of our equipment over the last forty years offering a cost-effective solution including L2 Leakage Class, D1 Deflection Class, TB1 Thermal Bridging and T2 thermal Transmittance. This is complimented by achieving standards set out in ERP 2016/18 and L2 Specific Fan Power.

To further ensure structural stability, rigidity and thermal qualities BS EN 1886:2007 standard provides the means for classifying the performance of all our air handling units.

The Air Handling Unit framework is constructed from a closed aluminium box section with heavy duty injection moulded ABS black nylon knock in corner pieces. This high density and lightweight structure ensures a strong and rigid framework for the Air Handling Unit.

Depending upon the project requirements panels can be either 25mm or 50mm thick. Panels are constructed from a galvanised sheet steel inner skin with a plastisol coated or galvanised sheet steel outer skin with mineral wool insulation sandwiched between the sheets. Our standard plastisol colour is Goosewing Grey RAL10A05, other colours are available on request.

Our standard mineral wool insulation has a density of 100kg/m<sup>3</sup>.

As standard each complete unit or modular section would be factory assembled on a full perimeter base to ensure full structural stability.

All externally mounted units would be fully sealed and completed with an overhanging pitched roof to prevent water ingress.

Depending upon site access all of our Air Handling Units can be supplied as modular sections, component form or fully assembled on a single piece base frame and still conform to the standards set out above.

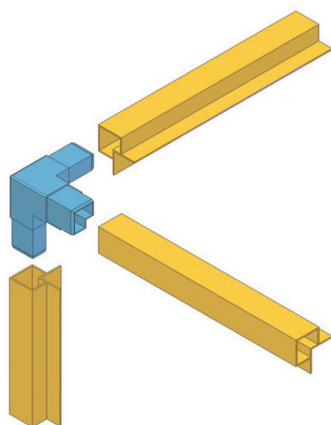
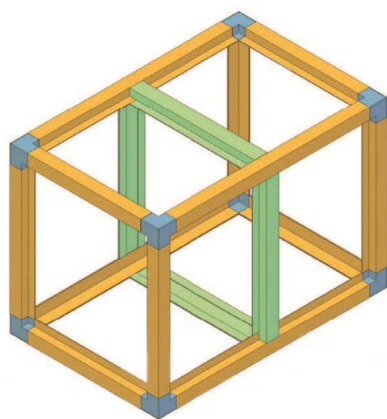

# Asset Information

This AHU mounted web based portal augments our customer experience by providing you with all your BIM Level 2 files for your job specific, bespoke, Air Handling Unit as defined at the design stage.



### Asset Information

Either show the QR code to your code reader app of choice, or visit <https://asset.eceuk.com/> and enter the reference number below

## 682 528 185 640 707 446



Pharaoh House, Arncliffe Close, Medway City Estate,  
Rochester, Kent ME2 4QW  
[www.eceuk.com](http://www.eceuk.com) e mail : [aftersales@eceuk.com](mailto:aftersales@eceuk.com)

This allows building maintenance teams, consultants and contractors unique access to one of the most productive portals available.

Here is just some of the great features that our portal offers:

- 3D models to go into your Building Management System, such as Revit (.step, .sat, .ifc, .dwg (3D), etc).
- 3D models that can be interacted with in real-time using augmented reality devices (such as a Microsoft HoloLens).
- 2D Certified Drawings (.dwg for loading into AutoCAD / DraftSight and .pdf for opening on any device, anywhere).
- Consumables Information (such as Filters, Motors, Sensors and Actuators).
- Single click Basket for consumables with Anything Air Handling, our Spares & Parts shop [www.aahuk.com](http://www.aahuk.com).
- Controls Documents (if your AHU has one of our controls package).
- Refrigeration Unit Information.
- Installation, Operation and Maintenance Manual.
- Recycling Manual.

All you need to access this information is a unique reference number and an email address. To make it really easy each of our units now come with an Asset Information plate allowing you on-premises access to all the information from your mobile device.

**TRY IT! Scan the QR and enter the code**





## Did you know...?

- on a DX system the indoor coil is mounted internal to the AHU and outdoor coil is the condensing unit.
- when matching indoor to outdoor coils HEX volume, Air Volume, Coil Capacity and Coil Circuitry should match.
- at peak times during summer and winter, outdoor coil capacities on DX systems can reduce by up to 20%. Dependent on ambient temperatures.
- minimum air on temperature in heating mode for a DX system indoor coil is 10°C.
- swings in temperature are often caused by DX run on times and single circuit DX systems supplying small areas. This is more prevalent in small areas and with air volumes below 1.0 m<sup>3</sup>/s. Twin circuits will often reduce the risk of this happening.
- by supplying twin circuits you reduce the risk of cold air being pumped into the area served when one circuit is in defrost.
- some DX units have eleven capacity steps whereas others may only have five.
- the term "vertical unit" has the same meaning as double stacking and or piggy back arrangement.
- if you're concerned about the equipment access route, ECE can offer a free site survey.
- ECE can offer a long reach HIAB vehicle with a reach of 27 meters holding one tonne.
- if ECE supply the AHU, Controls and DX equipment the AHU warranty is extended to two years.
- ECE offer a 5 year warranty on its iQ range of controllers.
- ECE offer a 5 year warranty on its DX units.
- ErP requires supply systems to have minimum ePM 2.5 50% grade filtration.
- Location, Internal or External.
- Delivery in modules or packaged in one piece (dimensions limits apply).
- Units also available "Dry Built" for site off load, dismantle, carry through, re-assemble, join and seal.
- Units also available in component form for site offload, carry through, re-assemble, join and seal.
- Fewer pressure producing components reduces the overall energy consumption thus reducing carbon footprint, SFP and running costs of the AHU.
- AHU cooler and heater duties will incorporate coolth and heat recovery capacity and reduce the size of the indirect or direct heating and cooling equipment. This will reduce the indirect or direct heating and cooling equipment cost to the client by up to 20%.
- AHU's can include EC Fans (IE4 Motors) to give the highest possible efficiency and the lowest life cycle cost.
- By removing the frost coil this increases heat recovery efficiency as the delta t between return air and fresh air is greater. Thus more energy is available for recovery.

### ECE UK Ltd.

**T** +44 (0)1634729690  
**E** sales@eceuk.com  
**W** www.eceuk.com  
**A** Pharaoh House, Arnolde  
Close, Rochester, Kent,  
ME2 4QW

