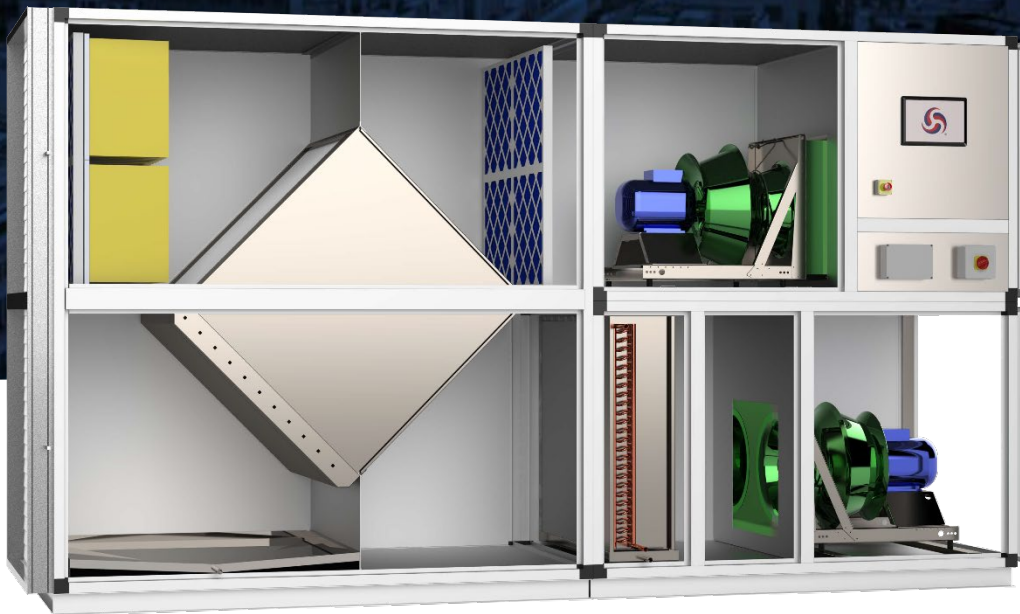



Plate Exchanger Aluminium 3-way Mix PXA3MX

Original Instructions Air Handling Units
Installation, Operations and
Maintenance Manual



2022 Release

ECE UK LTD Pharaoh House, Arnolde Close, Rochester, Kent. ME2 4QW



Purpose

This manual contains advice for installers and users.

General information about the range, construction and selection of ECE air handling/conditioning equipment can be obtained from our website, various sales publications, or by telephone.

Certified individual unit data concerning dimensions, weights, component specification and performance, is issued with the order acknowledgement for each unit.

Due to our policy of continuous improvement the information contained within this Manual may be altered from time to time without prior notice.

Table of Contents

Table of Contents	3
PXA Principle and Operation	10
Basic Principles	11
Heat transmission	11
Leakage	12
Condensation	12
Frost Limit	13
Temperature efficiency	13
Pressure drop	13
Pressure difference	14
External pressure difference	14
Internal pressure difference	14
Checks at Design Stage	15
Air Inlets and Discharges	16
Acoustics – Vibration	18
Services – Connections	18
Commissioning & Fault Finding	18
Maintenance Repair and Renewal	19
General	19
PFP Minimum and Recommended Clearances	20
Checks at Order Stage	21
Delivery	24
Receipt & Unpacking	25
Fan Transport inspection	26
Fan Intermediate storage	26
Lifting	27
Crane - Long lifting straps (150mm min. width)	27
Crane – “H Frame” Short lifting straps (150mm min. width)	27
Lifting – With Base Frame Lifting Holes	28
Crane - Long lifting straps (150mm min. width)	28
Crane – “H Frame” Short lifting straps (150mm min. width)	28
Forklift	29
Rollers	29
Skates	29
Toe Jacks	30
Installation	31
General	32
Hinged Handle Access	32
Compression Latch-Hinge	33
Bases and foundations	35
Transport and Installation of Component Form Plate Heat Exchanger	36
Transport	37
Assembly on site	37
Mechanical Installation	38
Exchanger width	39

Damper Drive	40
Condensate drain connection.....	40
Plug Fans	40
Fitting the Accessories	40
Electrical Connections.....	40
RLM Installation.....	41
Electrical Connections	41
Safety Notes.....	41
Connections to the grid	42
Motor Protection	42
Motor Starting	42
PFP Fan Installation.....	43
Safety Instructions.....	43
Risk of Electrical Shocks.....	44
Safe Operating Area	44
Mechanical and Electrical Safety.....	45
Electro-Magnetic Compatibility	45
Data Plate	47
PFP Operation.....	48
Ambient operating conditions	48
PFP Accessory Installation.....	48
Inlet protection guard kit.....	49
PFP Electrical Connections	50
PFP 1.35kW 1-Phase	50
PFP 2.6kW 3-Phase	50
PFP 4kW-5.5kW 3-Phase	50
Power Supply	53
Control Board Connection	54
PFP 1.35kW 1-Phase	54
PFP 2.65kW 3-Phase	54
PFP 4kW-5.5kW 3-Phase	54
Connection Details	55
Analog.....	55
Modbus Communication	58
Enable Signal.....	59
Pressure And Flow Meter	60
Relay 3-Phase.....	61
Tachometric, Alarm and Filter Output.....	61
Input Impedances.....	62
PXA Unit Type & Performance Reference	63
Bypass in the fresh air.....	67
Bypass in the extract air.....	67
Design S.....	68
Design F.....	69
Construction types.....	69
Options.....	69
Leakage Test.....	70

Horizontal installation.....	70
Adapter H for actuator.....	71
PXA Unit Fan Type & Speed Control.....	72
RLM Technical Information	73
Product Description.....	73
Technical Data.....	73
Authorised use.....	74
Improper Use.....	74
Important Information	75
Operating Instructions.....	75
PFP Technical Information.....	76
Production Description.....	76
Technical Data.....	78
Dimensional Drawings.....	79
Operating Modes and Setting Options	80
PFP Speed Control	81
Analog Speed Control.....	81
Modbus Temporary Speed Control	81
Modbus Fixed Speed Control.....	81
Speed Control Curves Example	82
PFP Constant Air Flow.....	82
PFP Asynchronous Emulation.....	82
PFP PID Closed Control Loop.....	82
PFP Analog ref. PID closed control loop.....	83
PFP Modbus temporary ref. PID closed control loop.....	83
PFP Modbus Positive / Negative Feedback	84
PFP Changing The Operation Mode.....	84
PFP Volumeter Measurement System For Volume Flow Rate	85
PFP How To Calculate The Volume Flow Rate From The Pressure Probe	86
PFP Filter Alarm	87
PFP Change of limits	88
PFP Out of functioning range alarm.....	88
PFP Flying start (for 3-phase only).....	88
PFP Regeneration (for 3-phase only)	88
PFP Skip speed Range (for 3-phase only)	88
PFP Soft start	89
PFP Starting in Closed-loop torque control (for 5.5 kW drivers only).....	90
PFP Stop speed (for 5.5 kW drivers only)	90
PFP Locked rotor (for 5.5 kW drivers only).....	91
PFP Speed limitation.....	91
PFP Power limitation.....	91
PFP Output current limitation	91
PFP Input current limitation (for 1-phase only).....	92
PFP Bus voltage.....	92
PFP Motor voltage	92
PFP Enable Function.....	92
PFP Derating And Overheating Protections.....	93

Driver overheating: Derating	93
Motor overheating: Thermal Protector	93
PFP Master & Slave Mode	94
Master and Slave 0-5V PWM out	94
Master and Slave 0-10V PWM out	94
PFP Variable Switching Frequency (for 3-phase - 4 kW and 5.5 kW)	95
PFP Communication	95
PFP Modbus Communication Timeout	96
PFP Temporary holding register	97
Fixed holding register	97
Holding register description	98
Holding Register 0	98
Holding Register 1	98
Holding Register 2	98
Holding Register 7	99
Holding Register 16	99
Holding Register 21	99
Holding Register 31	99
Holding Register 32	99
Holding Register 33	100
Holding Register 34	100
Holding Register 35	100
Holding Register 36	101
Holding Register 45	101
Holding Register 46	101
Holding Register 47	102
Holding Register 48	102
Holding Register 50	102
Holding Register 51	102
Holding Register 52	102
Holding Register 53	103
Holding Register 54	103
Holding Register 55	103
Holding Register 56	103
Input register description	104
Fan info and Modbus registers	106
PFP Alarm Handling	106
Monitoring	106
Modbus registers - Alarm description	107
Blinking LED - Alarm description	107
Digital Alarm Output	108
Alarm Reset	108
PFP Driver Replacement	109
Trend - VSD2H Variable Isolator Speed Drives	109
VSD2H Variable Isolator Speed Description	109
VSD2H Variable Isolator Speed Features	109
Physical (dimensions in mm)	110

Functionality.....	111
Hardware.....	112
DIP Switch	118
Quick setup.....	119
Monitoring	119
Parameters.....	119
Diagnostics	119
I/O and hardware	119
User settings.....	119
Favourites.....	119
Digital Input Isolation.....	119
Ethernet Connection.....	120
RS485 Connection.....	120
Real Time Clock.....	120
Integrated RFI-filter	121
Integrated DC Choke	121
Integrated Stress Removal	121
External Keypad.....	121
ACC/VSD2H/Hand Held Kit.....	122
ACC/VSD2H/Door Mounting Kit	122
Hardware.....	123
Quick Setup	125
Uninterruptible Operation and Energy Saving	125
VFD and Motor Control.....	126
Software.....	127
SISO – Safety Isolators/Switch-disconnectors	128
Switches & Sensor	128
Features	128
Description	128
Range	129
Commissioning	130
Plate Exchanger Aluminium.....	131
Plug / SISW / DIDW Fans - Motors – Drives.....	132
Belt Drives	132
Anti-Vibration Mountings.....	134
Rubber Mountings	134
Spring Mountings.....	135
Selection Table.....	135
Checking Label Positioning.....	136
Hinged Handle Access.....	136
Compression Latch-Hinge.....	137
Servicing Filters.....	139
Mixing Boxes - Separation Boxes - Shut off VCD's - HRD's	140
Coils	140
Coil Connections.....	141
Setting Water Flow through Coils.....	141
Coil Condensate Drains	142

Draw Through Units and Blow Through Units with negative pressure (depression at trap).....	142
Blow through units with positive pressure at trap	143
Blow Through	145
Draw through coils with condensate pump	146
Mixing circuit using three-way mixing valves.	147
Chilled Water Cooling Coils	148
Hot Water Heating Coils.....	149
Steam Coils.....	150
Electric Heater Batteries	151
Gas Fired Heaters.....	152
Electronic Steam Humidifiers	154
RLM Commissioning.....	155
Safety Checks	155
Test Run.....	155
Checking the current consumption	155
Check for quiet running	155
Flow measuring device	156
Commissioning fans with frequency inverters	157
Instructions for fans with PM motors on external frequency inverters	157
Commissioning fans with integrated Danfoss FCP-106 frequency inverters	157
Commissioning fans with integrated NI-DV inverters	158
Connection.....	158
Frequency inverter activation options	158
Maintenance	159
Plate Heat Exchangers.....	160
Lifting of the Fan Motor	161
Lifting Beam.....	161
Working Load Limit.....	161
Installation of Lifting Beam is Permanently Mounted.....	161
Operation	162
Checks Prior To Use	162
Safety Instructions	162
RLM Fan Maintenance	163
Safety Notes.....	163
Inspection Intervals.....	164
Vibrations	164
Dismantling of the impeller	164
Inlet and discharge connections	165
Faults	165
Disposal of the product	165
Maintenance Schedule.....	166
SISW / DIDW - Fan Bearings.....	168
Spider Arm Bearing.....	168
Plummer Block Bearing.....	169
Replacing the filters (for HTM specification units).....	170
Motor Bearings.....	172
Motors without Grease Points	172

Motor Overheating	172
Washable Filters	172
Activated Carbon (Constantly Monitored)	172
Activated Carbon (disposable non-monitored)	172
Electric Heater Batteries	173
Dampers - Motors.....	173
Coils - General	173
DX Cooling Coils.....	173
Fault Finding.....	174
Centrifugal Fans.....	175
Electric Heaters.....	176
Cooling Coils	176
Heating Coils.....	178
Refrigeration.....	178
Fan Drive Belts.....	179

PXA Principle and Operation

Basic Principles

Plate Heat Exchangers operate within the guidelines for heat recovery (e.g. Eurovent 10, VDI 2071) as recuperates with joint faces (category 1). The heat releasing and heat absorbing air streams pass along the joint face, through which the heat is directly transmitted. Supply and exhaust air must therefore be brought together and flow through the heat exchanger.

Heat transmission

Plate heat exchangers transmits heat via the plates from the warm to the cold air stream. A much simplified calculation of recuperation power is:

$$Q_{hrs} = k \cdot A \cdot \Delta t$$

When temperatures are given, the transmitted heat performance is assumed by design characteristics.

The k-value is calculated from the thickness and heat conductivity of the plates, as well as heat transfer on both sides. In order to have efficient heat transmission, the thermal transfer 'k' must be high. It is for this reason that the profiles of the plates are continuously being improved using flow simulations and tests, as well as being adapted to new circumstances and requirements. The goal is to always attain the optimal ratio of efficiency and pressure drop for the application.

The development team of the plate are always working on new technologies so that it can react quickly to new market requirements. The high level of development processes contributes significantly to the long-term added value of the product and helps customers to illustrate this added value in their applications.

The transmitted heat performance can vary depending on the combination of exchanger size, plate spacing and implemented technology. In this way, the ratio of temperature efficiency and flow rate can be optimised for specific projects and adapted based on the results of an economic calculation.

Leakage

Components of air handling units, for example dampers, ducts or casings, are not normally 100% leak-proof. This is mainly because it is not necessary for correct functioning and it would be very expensive. In practical use, however, leakage must remain within technically acceptable limits. Therefore, test specifications and limits (EN 1751) exist for certain components, such as dampers. There is currently no corresponding data for heat recovery units, but actual valves have been identified through measurements.

A difference has to be made between the following:

- Leakage to outside (external)
- Leakage between supply air and exhaust air (internal)

While sealing to outside normally does not cause any problems (it is above all a question of assembly quality), this internal leakage mainly depends on the system and exchanger construction. As an approximate value for the internal leakage for the plate exchangers a maximum of 0.1% of the nominal air flowrate can be used (at 250 Pa pressure difference). The leak tightness of the plate heat exchanger is excellent in comparison to other constructions. Nevertheless, it must be noted that exchangers are not 100% leak-proof unless special measures are taken.

Condensation

Plate heat exchangers do not transmit humidity but still can use part of the latent heat of moist extract air. At low outside temperatures, when there is a high heat demand, the extract air is cooled down to such a degree that the saturation temperature is reached and condensation is formed. Thus the latent heat of evaporation is released. This reduces further cooling of the extract air, i.e. the temperature difference between the air streams in the plate heat exchanger is greater than when there is no condensation. Also the heat transfer is better; consequently the temperature efficiency is raised significantly. This can be seen clearly in the HX diagram. The cold air stream is heated more than the warm air is cooled. Nonetheless the enthalpy difference is the same, assuming equal water content.

Condensation in the extract air reduces the free area of the airway and is responsible for an increase in pressure drop. Therefore it is important that the condensation can drain away. This depends mainly on the fitting position of the heat exchangers and on the form of type plates. Plate heat exchangers offer advantages because of their special profiles.

If condensation occurs the internal and external leakage of the exchanger is of particular importance. Even with a leakage rate of only a maximum of 0.1% of the nominal air flowrate - as with the plate heat exchanger - up to 3 litres condensate an hour can leak out, even more in extreme cases. The absolute value depends on the size of the exchanger, the number of plates, the amount of condensate and the pressure difference.

Frost Limit

If the warm extract air stream is very strongly cooled condensate can be formed and it may even freeze. The fresh air temperature at which freezing starts is called the 'frost limit'. In practice this is rare as several factors must coincide:

- Very low temperature of the fresh air stream
- Fresh air volume is greater than the extract air volume
- High temperature efficiency of the exchanger
- Relatively little condensate
- The condensation cannot drain away easily

If several of these circumstances coincide the plate heat exchanger can ice up, starting at the cold corner. The Plate heat exchanger is not damaged, but the pressure drop is increased and the air flowrate is reduced. In extreme cases the whole exchanger can slowly ice up. It is recommended to calculate the frost limit for each project with the selection program and to take necessary precautions (de-icing exhaust fan switch, preheating, and bypass).

Temperature efficiency

In principle, nearly any temperature efficiency can be achieved if sized and designed to suit. For instance, the efficiency can be substantially raised by installing two exchangers in series. However, this increase in efficiency:

- Either is at the expense of a high pressure drop,
- Or at the expense of a large space requirement,
- And an increase in cost.

The 'correct' temperature efficiency depends on applicable regulations and on the economic calculation, i.e. on operating data such as energy prices, useful life, running times, temperatures, maintenance costs, interest rates, etc. It is important that the calculated optimum values for temperature efficiency and pressure drop are then put into practice. Even minor changes (a few percent lower temperature efficiency, a few Pascal's more pressure drop) can mean significantly poorer results for capital value and amortisation period.

Pressure drop

Heat recover units cause additional pressure drop on the exhaust and supply air sides; incurring higher running costs. Under present conditions the economical values range between 150 Pa and 250 Pa. However, to reduce costs, more and more heat recovery units whose pressure drops are above these economically reasonable values are being installed. This affects the feasibility of the system. But there is also an economic limit: the efficiency for generation of electrical current ranging between only 35% to 40%, the expenditure for the additional pressure drop must not exceed this value in relation to the energy savings in total.

Pressure difference

A distinction is made between:

- The external pressure difference
(Between inside and outside of the exchanger)
- The internal pressure difference
(Between exhaust air and supply air)

External pressure difference

This pressure difference has a major effect on the external leakage of the plate heat exchanger. Yet when the exchanger is properly and carefully installed in a ductwork system, its effect can be neglected. More important is the influence on mechanical resistance. Particularly the side walls are heavily stressed at big pressure differences. Therefore the side walls of a large plate heat exchanger will be strengthened with a special reinforcing section.

Internal pressure difference

Likewise, the internal pressure difference has a crucial influence on internal leakage between the two air streams. Plate heat exchangers are very tight in comparison with other constructions, the following should be considered when designing:

- The pressure difference in the heat exchanger should be kept to a minimum.
- The pressure gradient and thus leakage should be from the supply air to the exhaust air side

The internal pressure difference also may cause a deformation of the plates. The plate spacing is then narrowed and/or widened, resulting in corresponding variations of pressure drop. Extensive tests have shown that the influence of deformation depends on the plate spacing.

The permitted pressure difference between the two air streams is limited to:

- 2000 Pa for designs G and F
- 2500 Pa for design S

This is geared to the still acceptable pressure drop increase; a permanent deformation does not occur. The expected pressure drop increase depending on the exchanger type and the existing pressure difference can be calculated with the selection program.

Checks at Design Stage

Air Inlets and Discharges

Whether ducted, or part of the Air Handling Unit, inlet and discharge connections to atmosphere such as Louvres, Cowls, Spigots, etc. should be located and dimensioned so that the flow restriction, short circulating, recirculation of vitiated air, pick up of contaminated air or nuisance discharge of exhaust air do not occur.

Ducted intakes and discharges to units should be designed and constructed to ensure that flow restriction, turbulence, pre rotation, jetting, uneven velocity profile and surface or object excitation do not occur.

Poor intake design causes uneven velocity profile across unit components resulting in moisture carryover hence flooding, design supply air conditions not being achieved, electric heater elements overheating, DX refrigerant cooling coils freezing and secondary generation of noise and vibration etc.

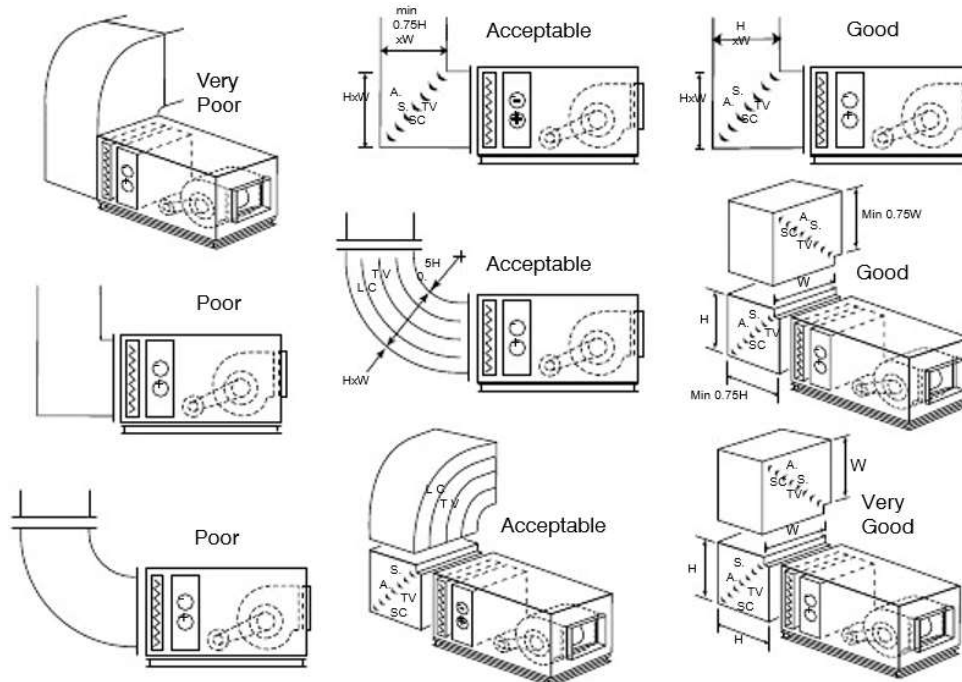

A.S. SCTV = Aerofoil Section Short Cord Turning Vane 50mm ctrs.
LCTV = Long Cord Turning Vanes to HEVAC – CIBSE – ASHRAE Standards

Poor discharge design causes reduction in fan pressure and volume, also turbulence generating secondary noise and vibration, which may reduce impeller, bearing, isolator and flexible connection life. Design supply conditions may also be achieved. Electric elements may overheat. DX coils may freeze.

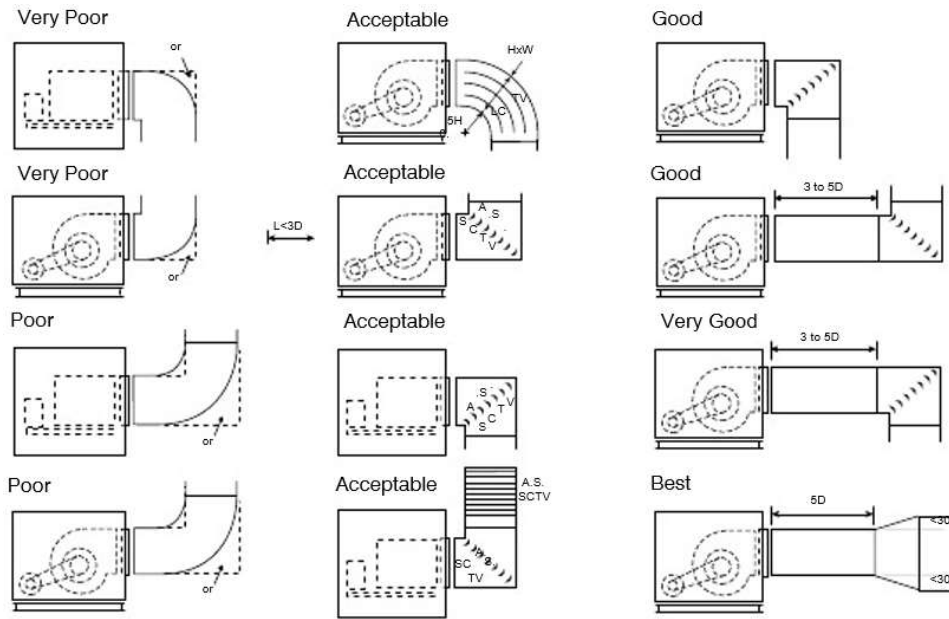

A.S. SCTV = Aerofoil Section Short Cord Turning Vane 50mm ctrs.
 D = Fan inlet eye diameter
 LCTV = Long Cord Turning Vanes to HEVAC – CIBSE – ASHRAE Standards

Acoustics – Vibration

Ensure space exists for incorporating attenuation of the noise to atmosphere from outside air inlet and exhaust air discharge and on room side supply and extract ducts.

Consider noise from casing radiation, flanking and breakout.

Consider primary and secondary vibration isolation including service connections.

Services – Connections

Ensure space with clearance exists for access to, routing of, connection to and expansion and contraction of water, steam, refrigerant, gas oil supplies and line fittings. Combustion air supply, flue gas exhaust. Venting of air, isolating and draining of plant, trapping and returning steam, condensate, trapping and draining of condensate from cooling coils, humidifiers and heat recovery devices to open tundish, blowing down waste to open tundish, pumping down and storing of refrigerant, power – control wiring, and components.

Commissioning & Fault Finding

Ensure plant is designed to allow installation of and access to calibration and adjustment of measuring and modulating devices for:

- Air flow direction and rate
- Medium flow direction and rate
- Resistance to airflow
- Resistance to medium flow
- Air on and off dry bulb, wet bulb and humidity
- Medium on and off pressure and temperature

Ensure space exists in and around the plant for access to, inspection of, measuring of and work on items including:

- Belt tensioning of external motors
- Jacking and levelling of steel spring vibration isolators
- Clear sight of identifying labels measuring and recording devices
- VCD blades, links and actuators, humidifier generators, sparge pipes, coil and eliminator surfaces and drain pans, electric heaters, fan and drives
- Fan speed and direction of rotation
- Motor current, resistance, continuity
- Motor nameplate
- Terminal wiring diagrams
- Wiring

Maintenance Repair and Renewal

For units with one piece coils ensure space exists of at least one unit width plus 150mm on the withdrawal side of each plant item. For units with split coils ensure at least half the width of the unit or 700mm whichever is greater.

Adjacent units can share the common space between them for access and withdrawal.

Ensure room exists for safe working platforms where units are mounted at high level.

Ensure provision exists for steps, ladders and mezzanine. Where units are over 1750mm high or mounted on platforms which elevate the unit height and make access difficult.

General

Any or all of the following and their effect on the plant should be considered and the appropriate action taken:

- Conditions within surrounding areas
- External temperature and humidity
- Direct solar radiation
- Wind speed and direction
- Driven rain
- Driven snow
- Driven sand
- Sea spray, mist, fog, moisture in suspension
- Saline atmosphere
- Icing
- Unit surface temperatures and surrounding air dew point
- Gases which form acids in solution in water, such as SO²
- Flammability
- Explosion risk
- Toxicity
- Bacteria
- Fungi
- Algae

PFP Minimum and Recommended Clearances

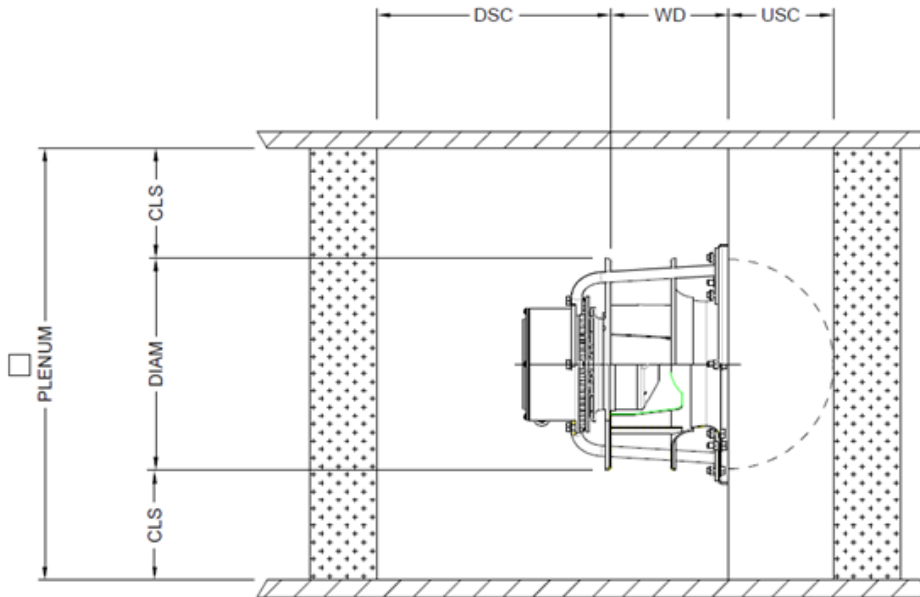

PFP ref.	DIAM	DSC	USC	WD	Minimum		Recommended	
					CLS	Plenum	CLS	Plenum
280	280	280	140	186	84	448	112	504
315	315	315	158	206	95	504	126	567
355	355	355	178	231	107	568	142	639
400	400	400	200	256	120	640	160	720
450	450	450	225	284	135	720	180	810
500	500	500	250	308	150	800	200	900
560	560	560	280	345	168	896	224	1008
630	630	630	315	TBC	189	1008	252	1134

Checks at Order Stage

General Information

Date Time
Contact(s)
Company
Address
Phone Number
Fax Number
Email Address

Retentivity (Act. Carbon) BS. ASHRAE. Eurovent
Withdrawal - Side / Front
Fitted Manometer(s) Magnehelic(s)
Radiant Heat from EAHB

Contract Information

Customer Ref. No.
Confidential?
Job Name
Delivery Area
Specification Pages
Other Standards Referred To In Spec
Drawing No's.
Schedule Reference
Other Customer Documents

Inlets and Discharges

Louvres / FAI / DTA / Std / Acoustic Elmnts + Drain
High Velocity
Fan Discharge 45° Spigot + Mesh

Separation / Mixing Boxes / VCDs

Int / Ext Dampers
FAI / RC / DTA Position
Opp / Par / Man / Motor Belimo

Volume Control

100% / Zone / F&BP / Location Int / Ext.
Opp / Par / Man / Motor Construction GSS

Heating / Cooling

Heat Recovery
Heat Rejection
Dehumidifying
Humidifying
Positon / Type
Draw Through / Blow Through
Volume M3/s
Air On Cwlb / Deb / Kg / Kg
Air Off Cwlb / Db / Kg / Kg
Sweating Ins Frame
Dx + Const Off = Freeze
Humid Posn Adj Surfaces - Wetting
Clear Distance Downstream
Gas Heater. Condensation - Bypass
Combst'n Air Inlet - Flue Output. Posn
Load / Eff / Output
Steps / Interplated / Face
Medium Type
Flow Return °c
Evap. Temp. °c
Pressure – Bar / Kpa
Glycol %
Outside Ambient
Cond. Temp. C
Elec Supply
EAHB Min Air Flow Speed
EAHB Balanced Across 3ph Supply Interlock With
Var.Sp.Fan.
Construction
Plates / Tubes / Fins Elements / Burner / Infill
Finish: Self / Vinyl / Et.
Free Cooling & Mechanical Top Up. Air Entering At
90° to Coil Face.
Face Velocity Profile
Condensate Drain Provision – Height

Unit Information

Item No Area Ref
Supply / Extract
Int / Ext / Roof / Fitted Works or Site
Part / Horiz
Part / Vert Configuration / Sketch 25mm -
50mm Panels

External System Resistance

Depression at Unit Inlet
Positive at Fan Discharge
Pressurised Sep / Mix Box / Plenum
Diffusion / Blanking Screen? One-Two-
Duplex-Triplex DIDW - SISW
FC / BC BD / DD
Raft / Rigid
I.G.V. + Controller NRD's One. Two.
Guards:
Inlet / Eyes / Disch / Drive

Drives

Motors Int / Ext Duty / Idling
Pulleys / Belts / In / Out / Air Stream 1
Speed / 2 Speed / Variable Speed
Spd Change Interlock with EAHB.
Pole Change/Dual Wound.
Electromagnetic Clutch (TASC) Switched
Reluctance
Inverter DOL / SD
St' D/Fif
Elec Supply Floor Grid
Lifting Beams

Filters

Presti.Stii
St.l. 11.111.
To Extract Heat Recovery Grease to
Kitchen Extract Type
Efficiency by Weight Efficiency Spot Dust

Plenums

Location / Function Diffuser / Spacer / Access 90° /
Horz / Vert
To / From: Above / Below / LHS / RHS Hinged / Lift Off.
Tool Op / Handles / Lock To One Handle Viewport(s)
Bulkhead Light(s) Ext Switch Wiring by Others
Floor Grids

Inlet / Discharges

From: Above / Below / LHS / RHS / Face Louvre /
Spigot
Stack & Cowl 90° + Sctv
Grill / SD / DD / NV / OBDs Construction
Finish

Vibration Isolators

Int / Ext
Eff Required %
Rubber in Shear / Steel Spring Jacking
Self-Levelling Fixed/Loose

Flexibles

Isolating / Fan Raft / Fan Section Compute Unit / Pipe
Connections Attenuating
Flame Resistant Construction Finish
Breakout Flanking

Attenuators

Extract / Atmos / Room Side / Zone Supply / Atmos / Room
Side / Zone To Achieve NR In / At
Unit/Duct Mounted Straight /90 + SCTV Volume m3/s
Inlet / Outlet Plenum / Length
From / To / Above / Below / LHS / RHS / Face
Finish Breakout Flanking

Ancillaries

50 x 100 x 50 Full Perimeter Base 6mm Anodised
Aluminium
3mm GSS Integral Lugs Support Legs Support
Steelwork
Side / Central Services Corridors Pipework
Controls Wiring
Access Platforms

Construction

Frame / GSS / Ali / Plastisol Outer Panels / GSS /
Plastisol Inner Skin / GSS / Plastisol St. St.
Insulation 20mm / 50mm / 65kg / m3

Finish

Location Ext / Int Anodised All Plastisol
GSS Self

Protection

Polystyrene Corners Cling Film Wrap Polystyrene
Boards
Rewrapped after Assembly

Site Costs

Site Supervision Work Required Site
Assembly Required
Safety Checks I.E. Gas Heaters
Guarantee Checks
I.E. Assembly Standards, Weathering and
Site Air Leakage Standards

Problems

Transport: Loaded Vehicle Obstacle
Clearance / Route Load Bearing Road
Closure / Stat Permissions Onloading /
Off Loading
Crane, Fork Lift Weight / Capacity Moving
On Site: Route / Loads / Method Building
Load Bearing
Max Size / Weight per Piece for Access
Dry Storage before Erection
Bases: Level / Load Brg / Relevelling
Dev's
Bolting Adjacent Sections Onsite
I.E. Heating & Cooling Coils
Access / Maintenance / Withdrawal Plant
Sun / Wind / Rain / Snow
Saline / Icing
Dust / Powder / Grit / Soot / Smoke /
Sand Tall Units on Plinths Side Walkway?
Are Top Access Door Catches In Reach?
Containment & Drainage of Leaks
Sloping, Differential Trapped
Condense Drains, To Open Tundish
Miswiring Motors Competent Electrician

Delivery

Receipt & Unpacking

Units are designed and manufactured according to ISO 9001

As part of our quality control system each unit undergoes a full pre-delivery inspection before loading. Units are then shrink wrapped to prevent ingress of foreign bodies or water during transportation.

All units are fitted with a full perimeter bases to facilitate lifting, moving and installation.



Unit wrapped ready for dispatch

Units should be inspected and any external damage or short delivery reported to ECE, **before unloading**.

We cannot accept responsibility for damage sustained during unloading from the delivery vehicle or on site.

Units must be off loaded, lifted and lowered using long lifting straps and timber blocks or using an “H” Frame with short lifting straps and timber blocks or a fork lift with extended forks.

Final lowering and side shifting to bring parallel faces together should be by toe jacks with timber blocks.

Internal joining bolts should never to be used to pull modules together.

Modules should never be rolled over to move across site.

Guidance notes for unloading and handling are given in the following pages.

Before commissioning all packaging materials must be removed from the units and cleared from the area.

Fan Transport inspection

Check the fan immediately after you receive it and make sure that it has not been damaged during transport. If you discover any damage, get in touch with the ECE aftersales without delay. Briefly rotate the fan impeller to see that it rotates easily. Check the information on the fan rating plate.

Faulty conditions in transporting may result in serious damage on the product.

Fan Intermediate storage

If the fan is to be switched off in between uses, the following needs to be taken in to account:

- The storage environment must be dry, dust-free and not have a high level of humidity (<70%)
- Storage temperature must be in between -25°C and + 40°C

Lifting

Crane - Long lifting straps (150mm min. width)

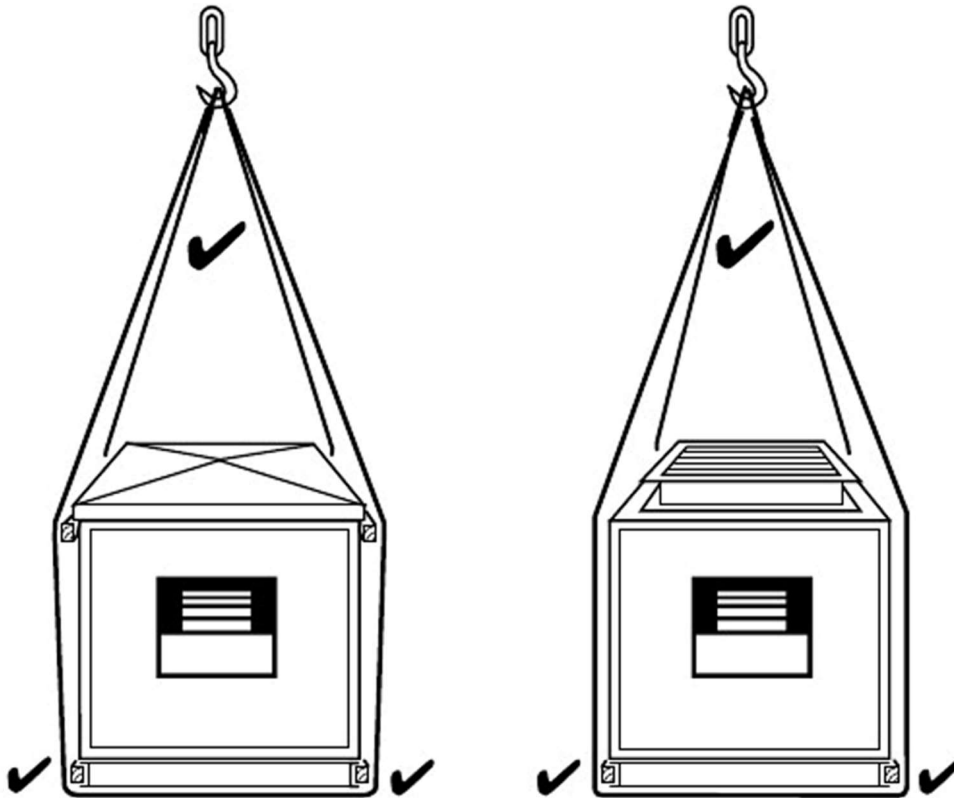

Crane – “H Frame” Short lifting straps (150mm min. width)

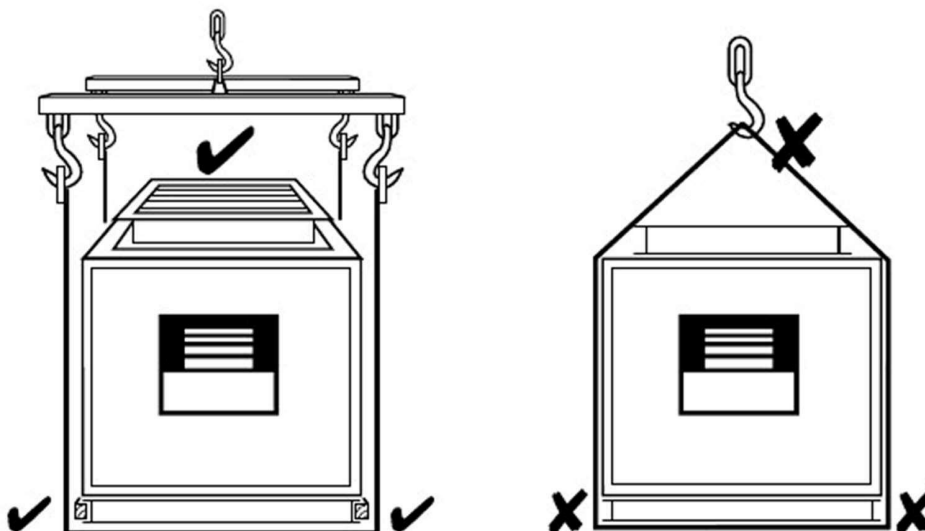

Lifting – With Base Frame Lifting Holes
Crane - Long lifting straps (150mm min. width)

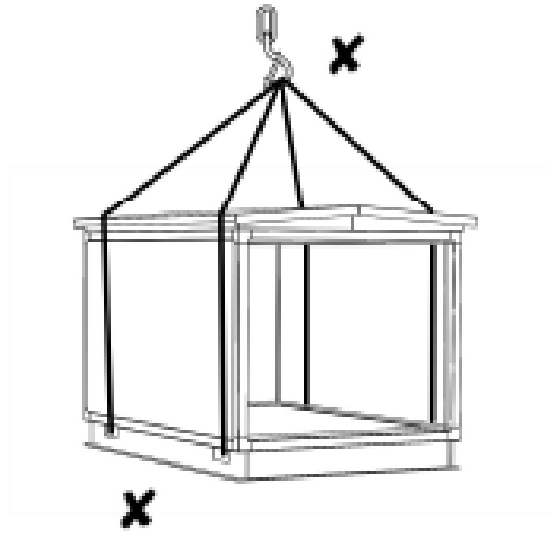
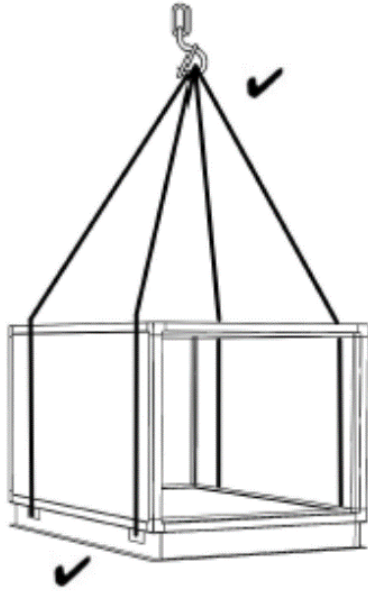

Crane – “H Frame” Short lifting straps (150mm min. width)

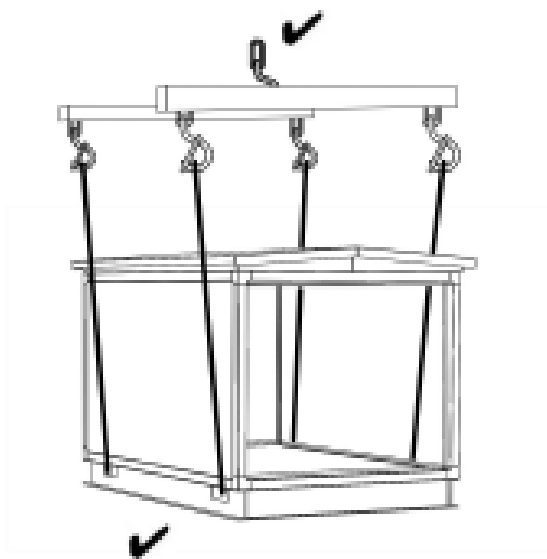

Forklift

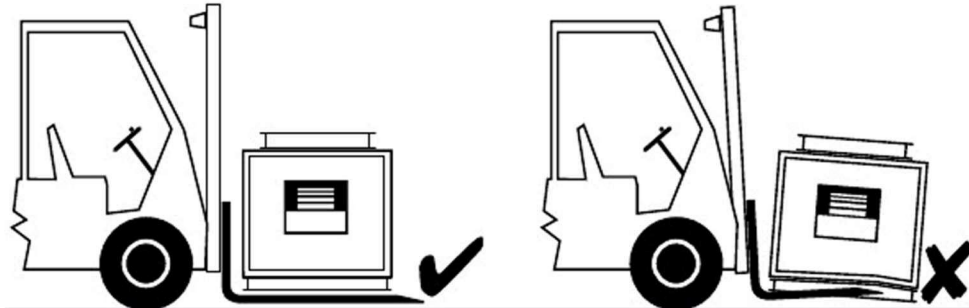

Rollers

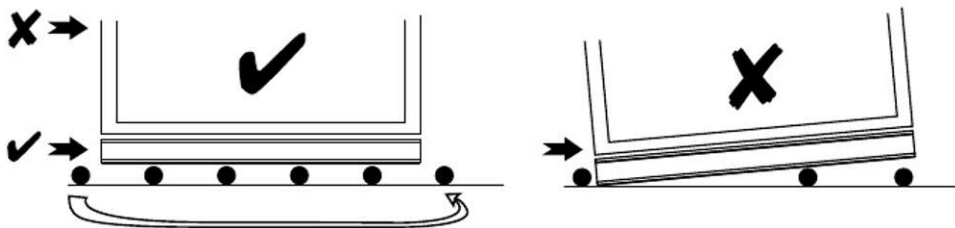

Skates

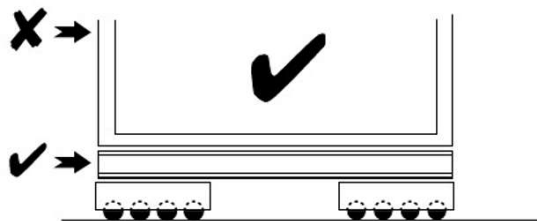

Toe Jacks

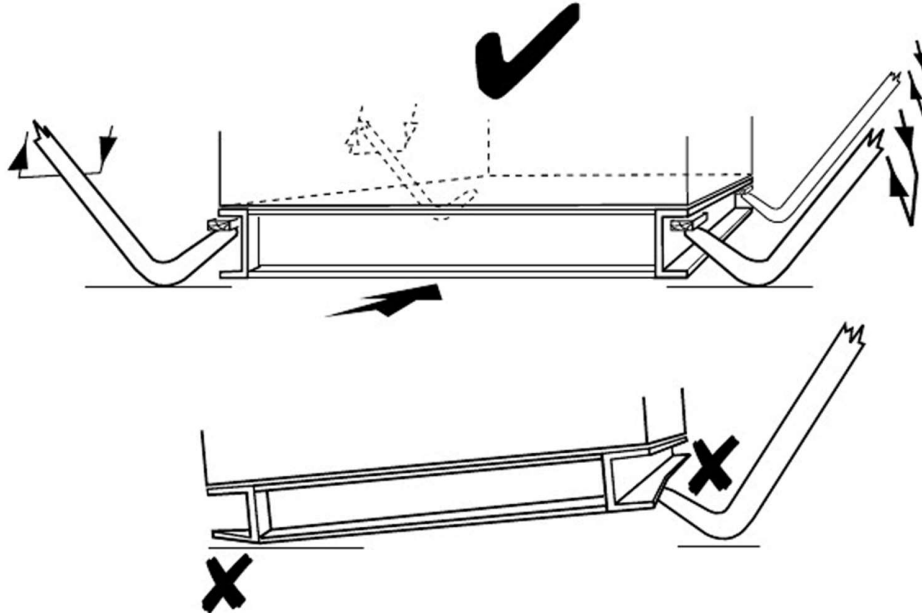

Installation

General

Electrical wiring and controls, water, steam, gas and refrigerant piping, line fittings and controls should be installed in accordance with appropriate governing institute standard practice (I.E.T. C.I.B.S.E. etc.) and together with the electricity supply, water supply and drains should conform to the appropriate authority and all statutory regulations.

Units with drains should be mounted at a level which allows installation of cleanable drain taps at each connecting point then installation of drain pipe work falling to an open tundish.

Space should exist for the application of sealant - jointing rubbers. Tightening of internal fixings. Internal installation, attachment or insertion of isolating, indicating, recoding, modulating, activating, devices, also making and tightening of fixings at connections to air Inlet and discharge ducts.

Hinged Handle Access

When working internal to the AHU you must remove the access doors completely to stop personnel getting locked inside.

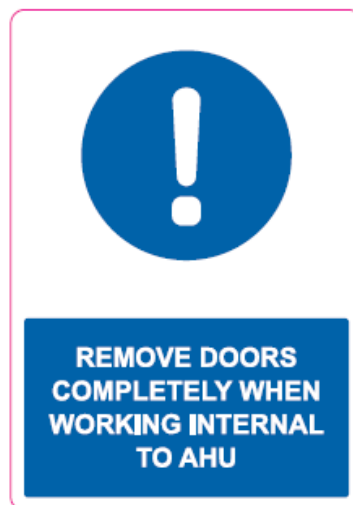

Compression Latch-Hinge

Product Details

- When the door is closed, the latch is adjustable (3mm) to achieve perfect alignment
- Compression (5 mm) with low opening & closing force
- Door or panel can be removed by unlatching the handles on both sides
- Right or left hinged
- Hinge 180° opening angle
- Available with or without pressure relief

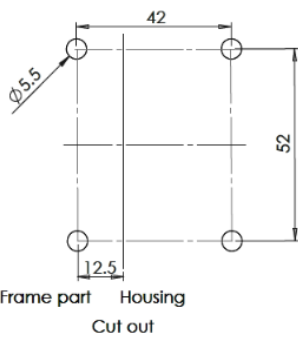
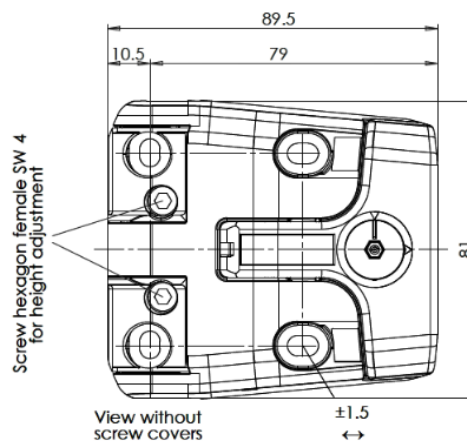
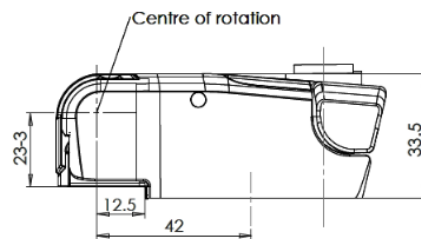
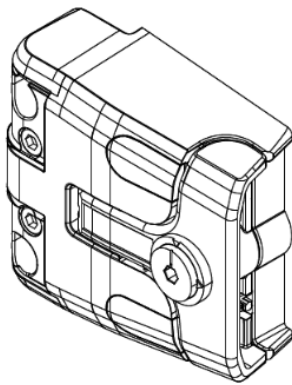

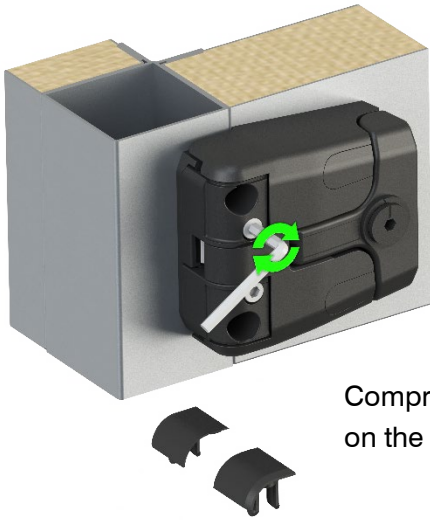

Compression adjustable
on the frame part

Compression
Latch-Hinge locked

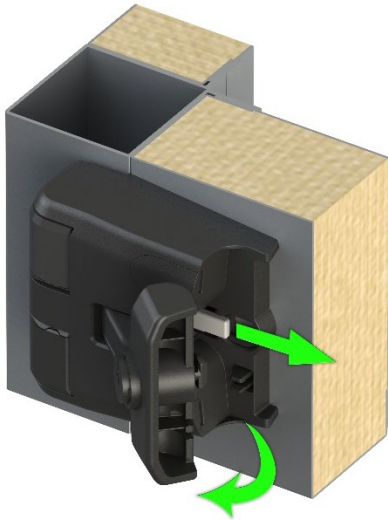
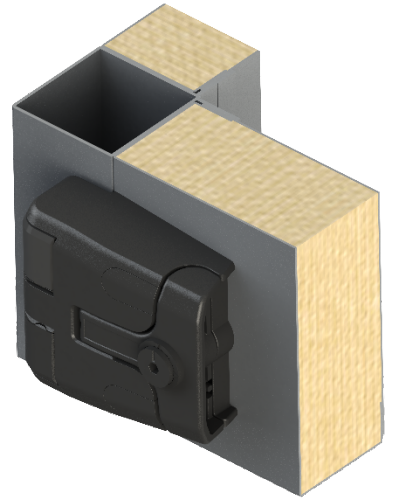

Latch-Hinge with pressure
relief, handle unlocked

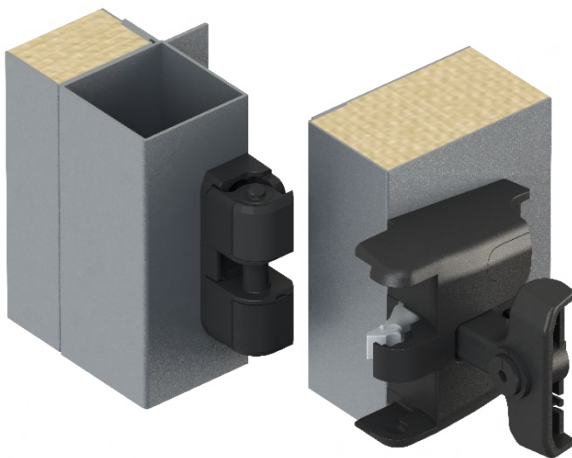
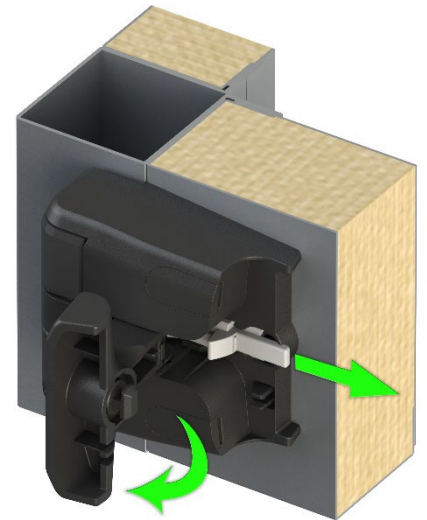

Latch-Hinge open

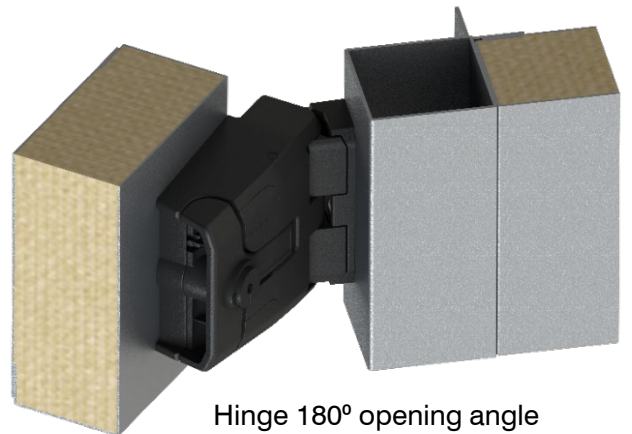

Hinge 180° opening angle

Bases and foundations

All units must be installed on a permanent base which must be firm, level and structurally rigid. Units may be mounted on suitable steels or purpose build C.I. frames supported from the main roof structure providing this is capable of support the weight – see Check at Design Stage.

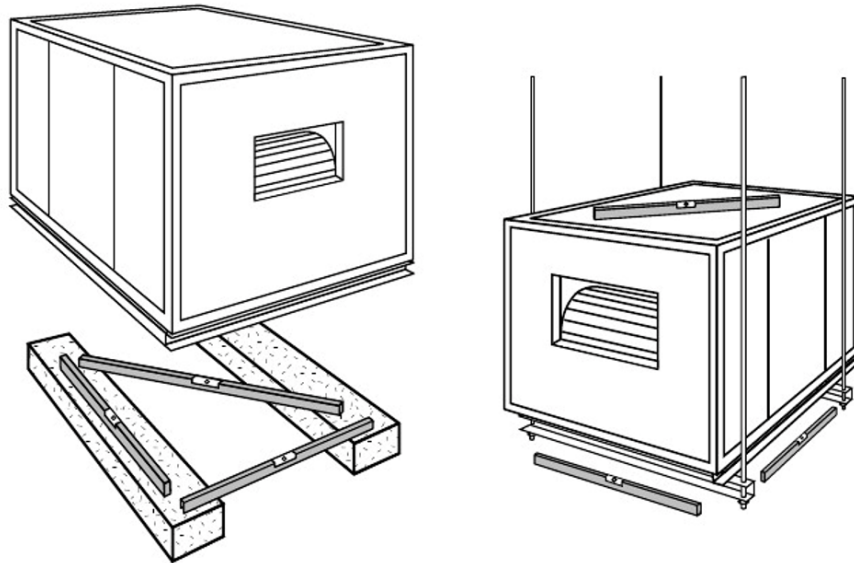

“The use of Tico material to dampen vibration / noise is not recommended as it will cause uneven deflection due to variations in point loading within units. This will cause vertical joints to go “out of parallel” causing leakage at joints”

When foundations are uneven units will “lozenge” if the installer attempts to use the joining bolts to pull non parallel faces together causing air leakage at joints, access doors will jam and not close after opening and duct connections will not be “parallel” and will leak.

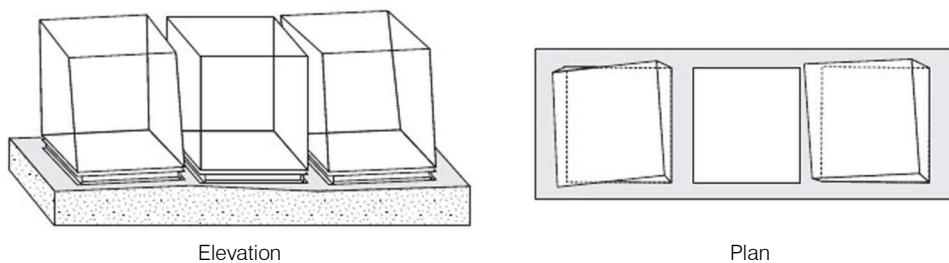

When foundations are level and perfectly flat units will be perfect cubes and will fit together squarely with good air seals, access doors will open and close correctly and duct connection are airtight.

Do not use joining bolts to pull units together in elevation or in plan.

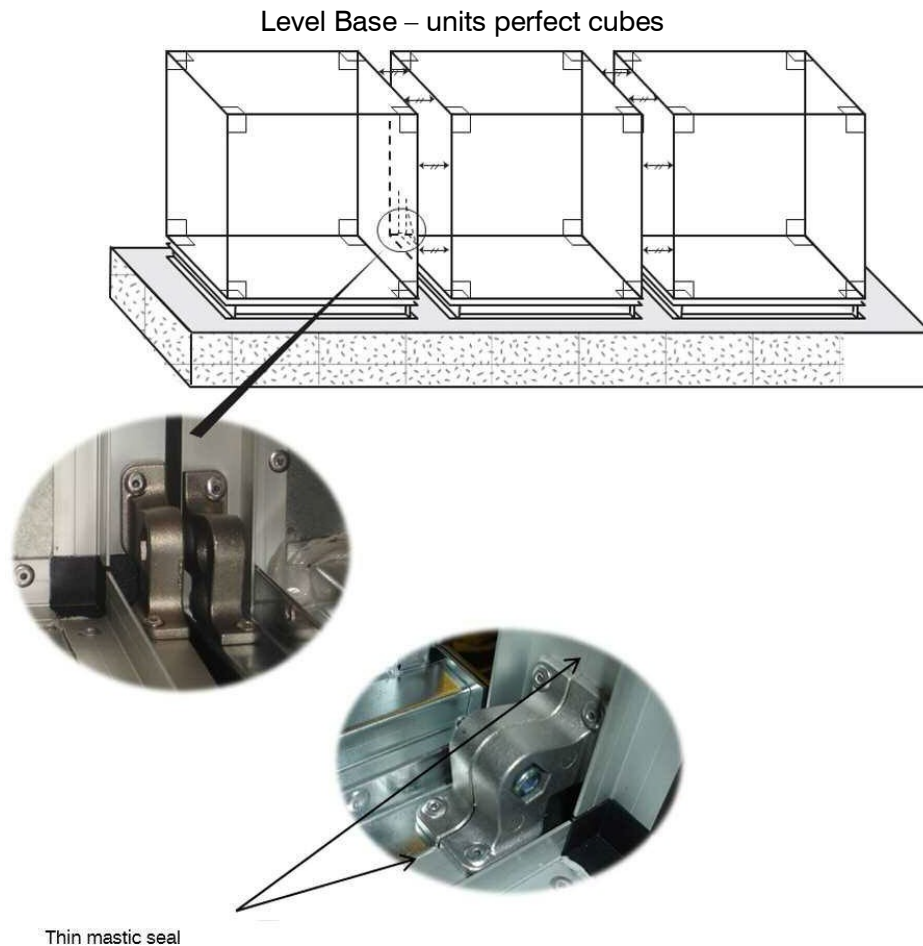

Transport and Installation of Component Form Plate Heat Exchanger

Plate Heat exchangers have no moving parts. Therefore they are easy to install and totally reliable in operation.

The following should be checked before installation:

- Has the plate heat exchanger been damaged during transport (visual check of casing and plate package)
- Has the correct type been delivered (design, series, size, plate spacing, options)
- How is the plate heat exchanger to be positioned (installation)

Transport

- The plates should always be vertical during transport.
- The exchangers may be lifted at the side walls, yet to avoid damage the tensile direction must be vertical (Parallel to the side wall). Also lifting facilities (hooks, loops, etc.) May be bolted to the returned edge of the side wall for transportation.
- The reinforcing sections on the side walls may also be used for lifting when present.
- Do not lift the exchanger at the aluminium corner section because this might cause damage to the corner sealing (leakage)
- Do not lift the exchanger at the reinforcing bar spacers of the bypass.
- In general: Do not suspend the exchanger in one point but always over a crane beam.

Assembly on site

Depending on local conditions (particularly for retro-fitting) it may be necessary to deliver the Plate Heat Exchanger in several parts. These must then be assembled on site by bolting and riveting. There are various possibilities for break-down of the exchanger:

In the width, sections can be manufactured as desired.

In the height and length, only compound exchangers can be divided. In this case the individual exchanger blocks can be supplied.

Also bypass and recirculation dampers can be delivered separately.

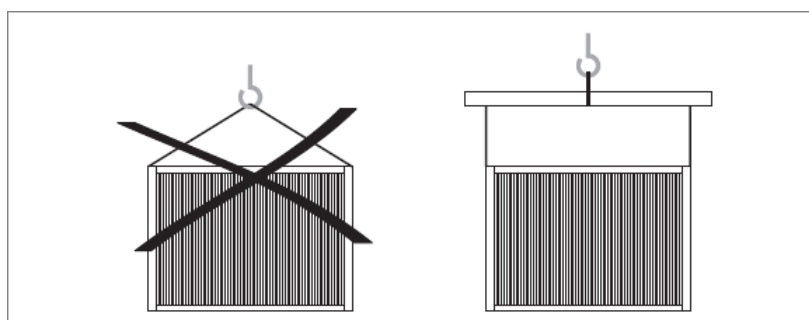

Fig. 29: Do not suspend the exchanger in one point!

Mechanical Installation

The Plate Heat Exchanger's construction offers particular advantages for installation into air handling units or connection to ducts or other ventilation equipment:

The corner sections of aluminium are hollow. They can be bolted or riveted without damaging the exchanger.

Also the flange of the side walls can be used for bolting and riveting.

The returned edge of the side wall allows easy installation of a sealing all round. It can also be used for side fastening (bolting, riveting).

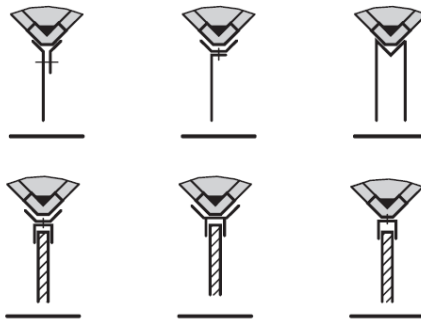

Fig. 30: Installation possibilities

Exchanger width

The width of the Plate Heat Exchangers can come as desired. It is possible to select according to the local conditions and also the design criteria (e.g Air Volume). Due to stability reasons the maximum exchanger width will be limited to 3000mm.

In order to simplify the transport and installation of the plate, the much wider plates of design S will be delivered in two parts. This will apply for the following plate sizes

Exchanger size	Partitioned design for:
S-040 to S-060	Width > 1400 mm
S-070 to S-240	Width > 2050 mm

Table 4: Partitioned delivery for design S

Several exchangers with dampers will be linked with connecting bolts when they are installed into the air handling unit. This will mean that one single actuator will be sufficient. In result to this, one or more connecting bolts will be provided, and this will depend on the exchanger size.

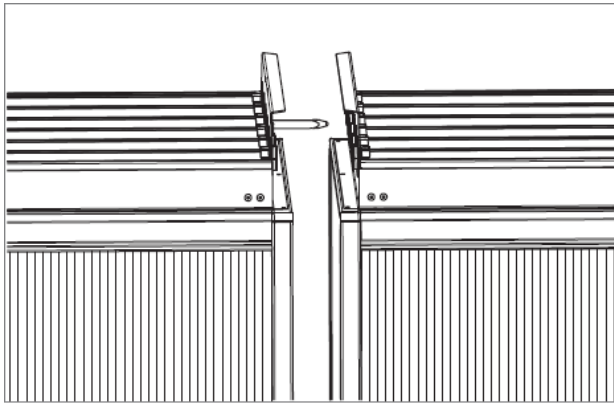

Fig. 17: Damper connection for partitioned exchangers

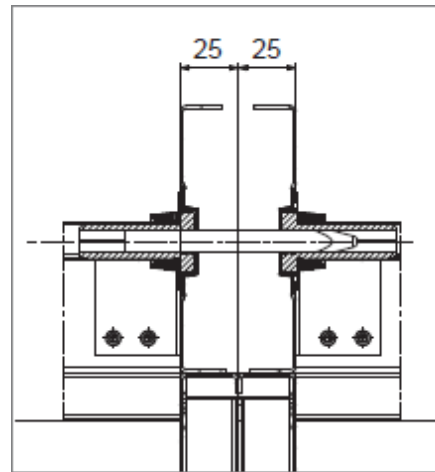

Fig. 18: Detail of connecting bolt

Damper Drive

When a bypass and dampers are fitted, remember to install the damper drive (check correct position of dampers). The supplied damper shaft is easy to install with the bearing and a collar.

Condensate drain connection

If condensation is expected make sure that this can drain away freely. The expected amount of condensate is calculated with the Plate Heat Exchanger computer program. Correspondingly sized condensate drains should be installed.

Plug Fans

The fan is secured to a base by bolts in mounting holes across anti-vibration mountings. The base must be level and stable. The fan must only be mounted in a horizontal plane. Either the fan or the base is mounted on anti-vibration mountings.



Fitting the Accessories

The fan should normally be connected to the air handling unit by means of flexible connection or other type of gasket to eliminate vibration transfer from fan to AHU casing. Providing necessary grounding for the accessories is within the constructor's field of responsibility. Inlet protective screen can be fitted directly to the front frame or outside AHU to the inlet opening.

Electrical Connections

All electrical connections must be wired by authorised personnel only. The necessary electrical and safety precautions must be taken into account. If the motor is operated across a frequency converter, the connections must be made according to the instructions of the frequency converter manufacturer. The motor must be grounded.

RLM Installation

Electrical Connections

Safety Notes

The electrical installation of the fans and components may only be carried out by trained personnel in observance of these Operating Instructions and the regulations in force.



The following Standards and guidelines are to be observed:

- IEC 60364-1 / DIN VDE 0100; DIN EN 60204-1
- site regulations of the Electricity Supply Companies
- Equipment in accordance with EN 60204-1 is to be installed as protection during unexpected events (e.g. an isolation switch for inspections).

Caution electrical hazard!



Electrical potential at intermediate circuit of Driver and power connections if the permanent magnet motor rotates!

- do not work at the fan if the impeller/motor is not locked
- lock fan impeller by proper means

Connections to the grid

Connect the fan to the grid according to the enclosed connection diagram or the enclosed operating instructions (of the drive).

CAUTION

- PM motors without integrated electronics may only be connected to a frequency inverter suitable for that purpose.
- It is not permitted to operate more than one of the permanent magnet motors with one frequency inverter
- Only use screened motor cables.
- The motor cable screen must be attached to both sides

Motor Protection

- Please check the maintenance instructions of the motor manufacturer
- Motors are to be protected against overload in accordance with EN 60204-1.
- Standard motor protection switches are to be provided and set to the nominal motor current. A higher setting is not permitted!
- Care must be taken to ensure for explosion protected motors that motor protection devices are utilised which correspond with the time given on the motor type plate.
- Motors with built-in thermistors or similar must be protected through a thermistor or similar operated release device.

CAUTION

Fuses or circuit breakers do not provide sufficient motor protection. Damage due to insufficient motor protection invalidates the manufacturer's guarantee.

Motor Starting

Motors with a nominal rating of 4kW can generally be direct started.

Motors with a nominal rating >4kW are usually star-delta or soft started. For frequency inverter operation the start-up ramp must be selected so that the current rating of the motor is not exceeded.

In all cases the power limitations provided by the existing power supply company must be taken into account.

In the event that plant conditions necessitate a direct start the suitability of the fan design is to be confirmed with ECEUK Ltd. Fans with high inertia impellers can take over 6 seconds to reach top running speed. In these cases heavy duty motor protection relays or bimetal relays must be provided.

The motors are designed for S1 continual operation. With more than three starts per hour the suitability of the motor is to be confirmed by ECEUK Ltd.

CAUTION

PM motors without integrated electronics must be operated at inverters suitable for that purpose! (e.g. Danfoss VLT HVAC Drive FC-100)

PFP Fan Installation



The fan installation must be carried out only by competent and qualified staff.



In the final installation, the device shall be directly connected to the supply terminals and shall have a contact separation in all poles, providing full disconnection under overvoltage category III conditions.

Safety Instructions

The following warnings, cautions and notes are provided for your safety and has a means of preventing damage to the product or components at the connected machines.



Before using the EC Fan PFP, read carefully the following general safety rules



The use and maintenance manual of any domestic appliance or similar device incorporating a PFP fan shall include the following clauses.



This appliance can be used by children aged from 8 years and above and persons with reduced physical, sensory or mental capabilities or lack of experience and knowledge on condition that they are supervised and instructed concerning use of the appliance in a safe way and understand the hazards involved.

- Children shall not play with the appliance.
- Cleaning and user maintenance shall not be made by children without supervision.

After taking off the packaging make sure that the fan is intact. In case of doubt do not use it and contact an Authorised service center.

Check that the fan is not damaged in any of its parts. The safety concept of the fan is valid only in perfect conditions.

Risk of Electrical Shocks

- Any damaged socket, connection terminal or cable must be replaced immediately by qualified technicians or by authorised service center.
- In case of repair or replacement of the connection cables and/or of the damaged devices or that do not work properly, please contact the authorised service center.
- Incorrect or improper installation may cause the system to malfunction and/or result in damage to people and/or property.
- Always disconnect the power supply before opening the fan.



Any installation and/or maintenance tasks are only to be carried out by skilled, specialist personnel.

Existing electrical systems must comply with the rules in force in the country where the PFP fan is installed.

Before doing any maintenance, make sure that the power supply and the batteries have been disconnected. Install an all-pole disconnecting device in the power supply system (in accordance with IEC 60335-1 or IEC 60204-1, as applicable).

Safe Operating Area

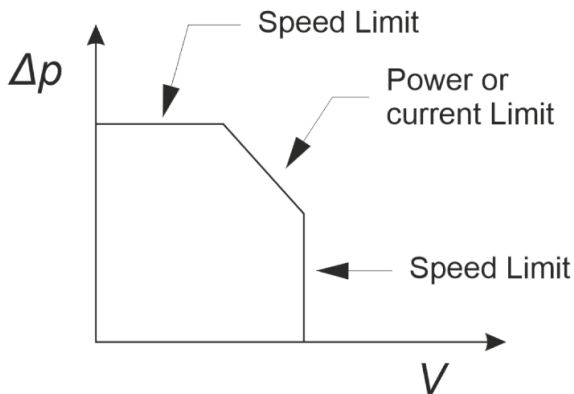

The drivers are protected against overload conditions and a safe operating area is defined by a limit of speed, output power and motor current.

Mechanical and Electrical Safety

These fans with EC drive systems are designed for incorporation in equipment, fulfilling the requirements set by the Machinery Directive (MD - Dir. 2006/42/EU), and those parts of the Low-Voltage Directive (Dir. 2014/35/EU) which are applicable in accordance with the MD, where it concerns electrical safety.

Electrical safety is generally achieved by application of the provisions of the EN 60204-1 standard “Electrical equipment of machines - General requirements”.

Such safety requirements are covered as far as necessary for a partly complete machine, sub-assembly or component, as these fans are specifically intended for incorporation within other machines. The responsibility for the mechanical and electrical safety of the installed fan is thus of the manufacturer of the complete machine and, for this reason, it is strictly forbidden to put the fan in operation before the manufacturer of the machine has assessed and declared that the complete machine fulfils all the essential safety requirements set forth by the MD. Please, check the Declaration of Incorporation which accompanies each product.

Electro-Magnetic Compatibility

Single-phase drive systems: PFP 1.35 kW

The drivers of these products incorporate an Active Power Factor Control module, to provide harmonics filtering and compliance with the EMC requirements applicable to domestic and equivalent environments (“first environment”), or with the advanced requirements for harmonic distortion which often apply to data centers.

Three-phase drive systems: PFP 2.6 kW, 4 kW, 5.5 kW

The drivers of these products are provided with basic EMI filters only. They are suitable for use in the “first environment”, under condition that they are incorporated into an apparatus, system or installation, which is neither a plug-in device nor a movable device. Such devices shall have to be installed and commissioned only by a professional.

All the PFP drivers, single and three-phase, comply with the immunity requirements set up in:

EN 61000-6-2 – Electromagnetic compatibility (EMC). Part 6-2: Generic standards. Generic standards - Immunity for industrial environments.

Concerning the emissions level, depending on the production model, the PFP drivers may comply either with the requirements set-up in:

EN 61000-6-3 – Electromagnetic compatibility (EMC). Part 6-3: Generic standards. Emission standard for residential, commercial and light-industrial environments or those defined in:

EN 61000-6-4 – Electromagnetic compatibility (EMC). Part 6-4: Generic standards - Emission standard for industrial environments.



Specific electrical safety and EMC standards are applied according to the available models of conformity declaration (identified as 985732 and 985748):

		EMC Standards	
		61000-6-3 (household)	61000-6-4 (industrial)
Electrical Safety Standards	60204 (machines)	985732	985748



To improve the Electromagnetic compatibility a ferrite should be put on the power supply cable (close to the driver). The compliancy to the standards is intended for a single fan.

No tests have been made on multiple installations.



The compliancy to the standards are intended for a single fan.

No tests have been made on multiple installations.



The EMC tests are conducted without 485 communication wire, analog signals or Bluetooth devices.

WARNING

The drivers installed in the PFP fans incorporate MOV-based surge-protection devices (SPDs) to protect the electronics from power surges.

These devices fulfil the requirements of the IEC 61000-6-2 and IEC 61000-4-5 standards for surge immunity and testing: they withstand without damage 1 kV pulses in differential mode, and 2 kV pulses in common mode.

The internally mounted SPD is a Type 3 SPD, in accordance with IEC 61643-11, intended for local protection of the sensitive electronics. Its design assumes that the power distribution network includes higher-level Type 2 and Type 1 SPDs, where required for protection against lightning strikes, and also against repeating lower-level power surges, generated by sources inside the local network, like any unfiltered contactors of highly-inductive loads (e.g. motors and transformers).

Without filtering or protection, regularly repeating differential-mode low-level voltage surges can lead to permanent damage to the electronics.

Data Plate

The manufacturer's identification plate is located on the fan.

Several safety warnings are applied to the fan; such warnings must be strictly followed by everyone dealing with this product.

The company is not to be held responsible for damage to property or accidents to people which might occur if the above-mentioned warnings are not observed. In such a case, the operator is the only person responsible.

The identification plate is located on the fan base plate.

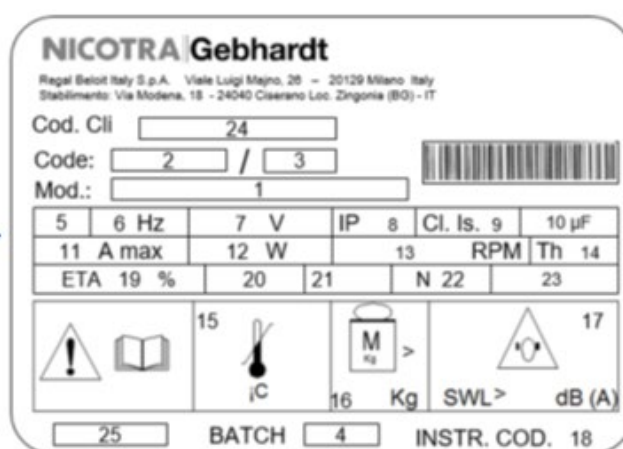
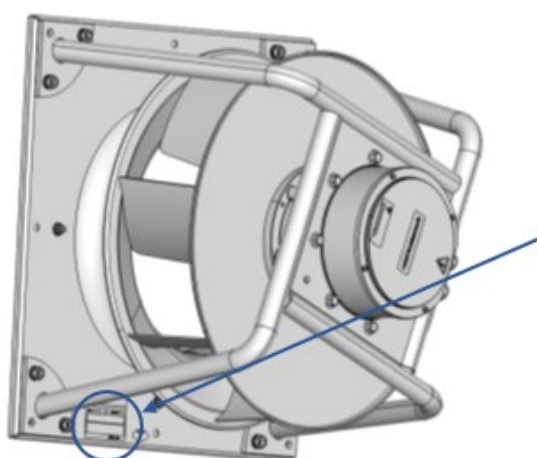

REF.	DESCRIPTION
1	MODEL DESIGNATION
2	REGAL BELOIT ITALY CODE
3	MODIFICATION LEVEL
4	PRODUCTION LOT NO.
5	NO. PHASES & CURRENT TYPE
6	ELECTRICAL FREQUENCY
7	VOLTAGE
8	IP PROTECTION GRADE
9	MOTOR INSULATION CLASS
10	CAPACITOR VALUE (WHEN PRESENT)
11	MAXIMUM CURRENT INPUT
12	MOTOR RATED POWER
13	RATED RPM

14	THERMAL PROTECTOR (Y/N)
15	OPERATING TEMPERATURE RANGE
16	UNIT EXCEEDS 30KG (Y/N)
17	UNIT EXCEEDS 85 dB (A) SOUND POWER (Y/N)
18	OPERATING MANUAL
19	OVERALL EFFICIENCY (η)
20	EFFICIENCY CATEGORY (STATIC OR TOTAL)
21	MEASUREMENT CATEGORY USED TO DETERMINE THE ENERGY EFFICIENCY (A-D)
22	EFFICIENCY GRADE AT OPTIMUM ENERGY EFFICIENCY POINT
23	ErP COMPLIANCE
24	CUSTOMER CODE (WHEN APPLICABLE)
25	PRODUCTION DATE

PFP Operation



WARNING

The driver must NOT be removed from the related PFP fan type and size.
The driver cannot be used separate from the related fan.



WARNING

Ensure correct grounding connections. The ground cable must be enough to carry the maximum supply fault current which normally will be limited by the fuses or MCB. Suitably rated fuses or MCB should be fitted in the main supply to the driver, according to any local legislation or codes.



CAUTION

The driver operates at high voltages.
Certain parameter settings may cause the driver to restart automatically after an input power failure.

Ambient operating conditions

The installation place must be in accordance with the IP protection degree of the fan. In this respect, refer to the ID plate described on the previous page.



CAUTION

Humidity Range: 90% non-condensing
Altitude: if the fan is to be installed at an altitude > 1000m, derating is required.
Shocks: do not drop the fan or expose it to sudden shock.
Vibration: do not install the fan in an area where it is likely to be exposed to constant vibrations.

PFP Accessory Installation

As previously mentioned, all the required options are generally installed by ECEUK Ltd before delivery. The following describes the composition, the main features and the mounting procedure of each accessory that is ordered separately.

Inlet protection guard kit

Materials

235 JR steel according to UNI EN 10025

Surface: Fe/Zn 8 according to UNI EN ISO 2081

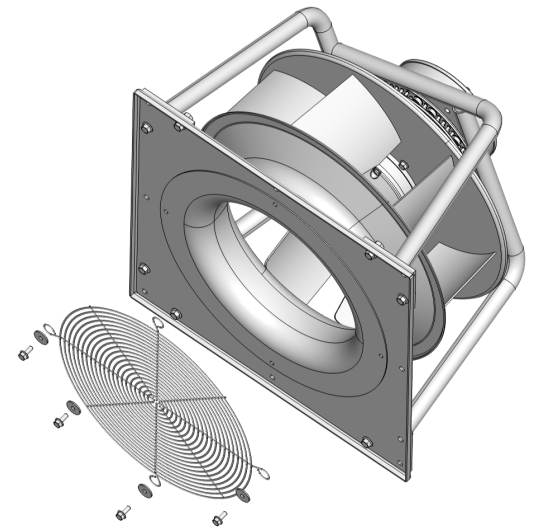
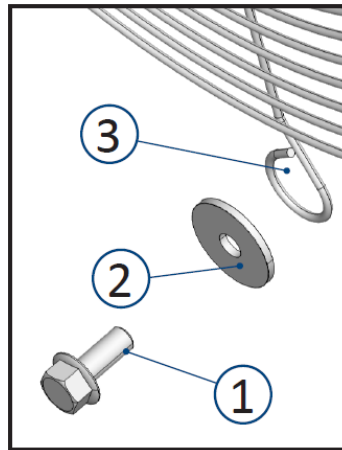
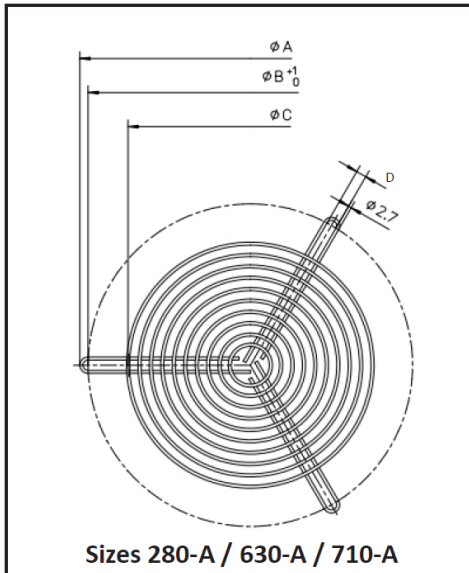

In order not to lose the alignment or when the guard is attached with four bolts, proceed as follows:

- overlap the protection guard;
- unscrew and screw bolts (1) and eyelets (2) to holes (3) one at a time.

Size	Code	A	B	C	D
280-A	6891A0	298.4	284	214	9
315-A	6891A1	342.4	317	274	-
355-A	6891A2	377.4	352	314	-
400-A	6891A3	417.4	392	354	-
450-A	6891A4	463.4	438	394	-
500-A	6891A5	513.4	488	434	-
560-A	6891A6	563.4	538	434	-
630-A	6891A7	615.4	601	494	11
710-A	6891A9	688.4	672	554	11

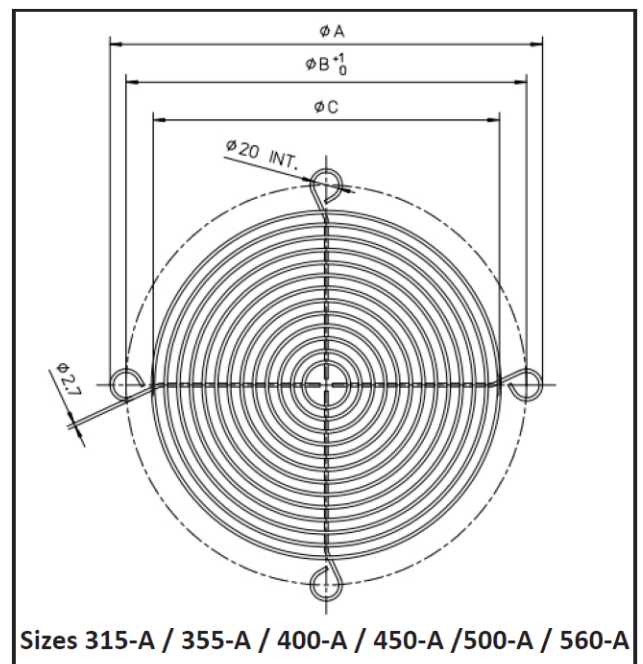

PFP Electrical Connections

PFP 1.35kW 1-Phase

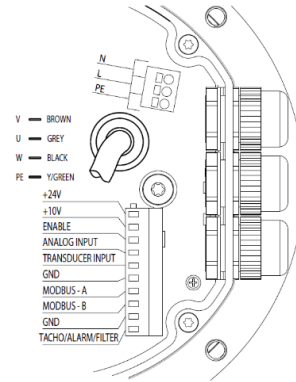
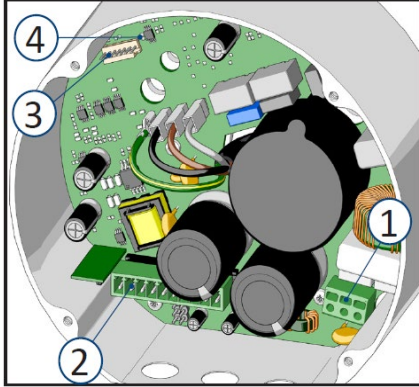

PFP 2.6kW 3-Phase

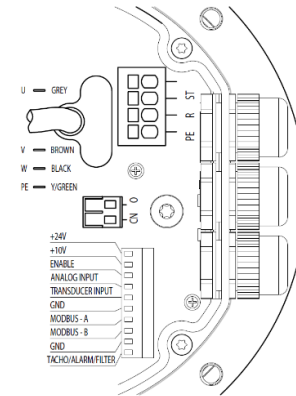
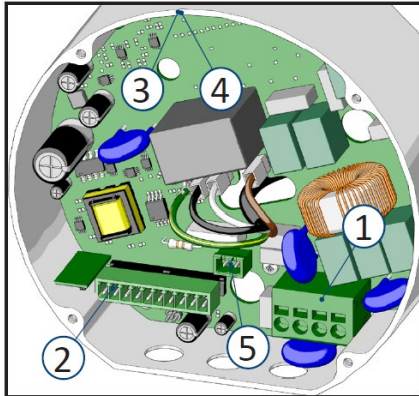

PFP 4kW-5.5kW 3-Phase

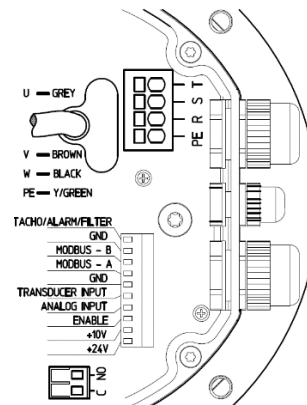
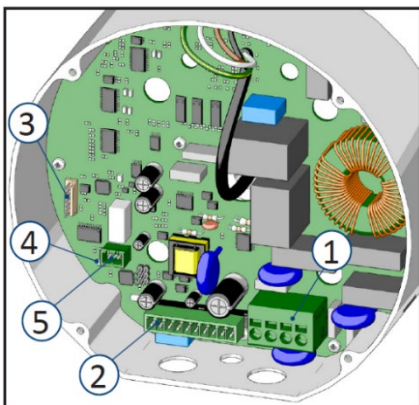

REF.	DESCRIPTION
1	Power supply
2	Control board connection
3	Communication
4	Blinking LED
5	Relay connection



Make sure that a differential switch (circuit breaker) has been installed upstream the line and that it functions properly.



Before carrying out any intervention on the electrical system, disconnect the power supply by means of main switch.

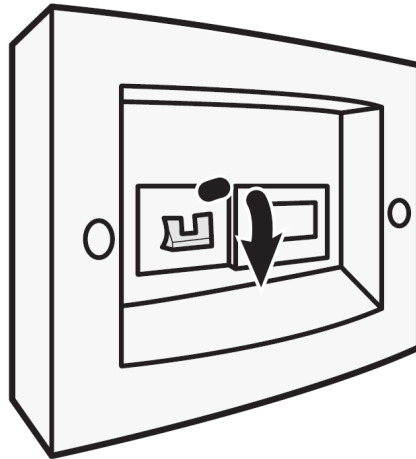

Work on the driver/fan by unqualified personnel or failure to comply with warnings can result in severe personal injury or serious damage to material.



WARNING

Only suitably qualified personnel trained in the set-up, installation, commissioning and operation of the product should carry out work on the driver/fan.

This driver must be grounded.

The power supply terminals L, N (1-Phase) or R, S, T (3-Phase) and the motor terminals U, V, W can carry dangerous voltages even if the driver is inoperative.

The drivers can be optionally connected by means of the following flush-type connectors:

- Phoenix Contact SACC-E-M12FS-8CON-PG9/0,5 (1) or compatible and Phoenix Contact SACC-E-M12MSS-3P-M16/0,5 PE or compatible for 1-phase drivers (2);
- Phoenix Contact SACC-E-M12FS-8CON-PG9/0,5 (1) or compatible and Phoenix Contact SACC-E-M12MSS-4CON-M16/0,5 PE or compatible for 3-phase drivers (2).

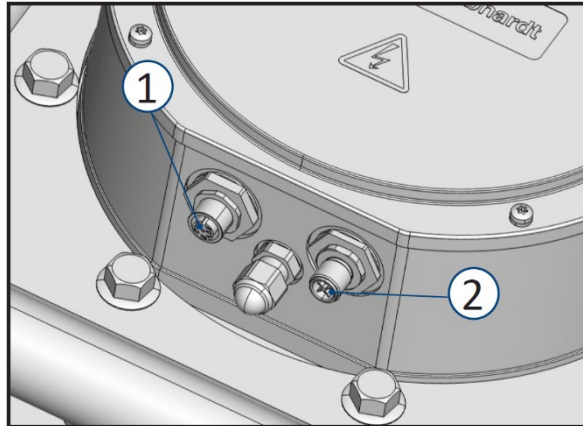

1-phase drivers

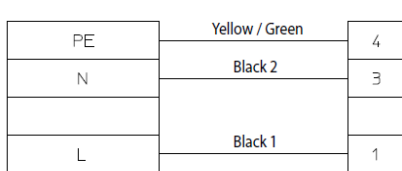
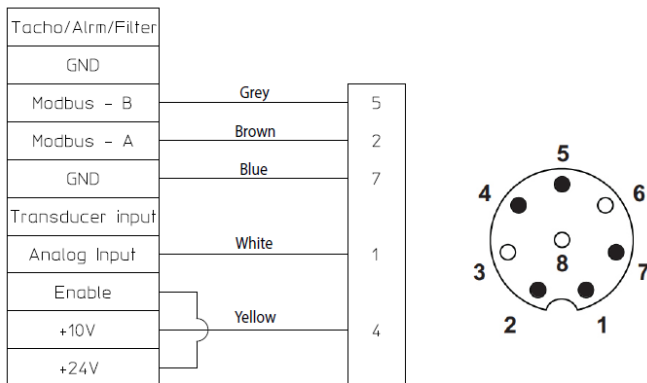

3-phase drivers

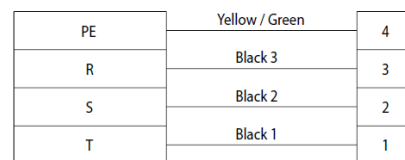
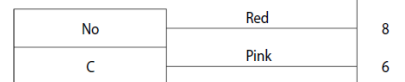
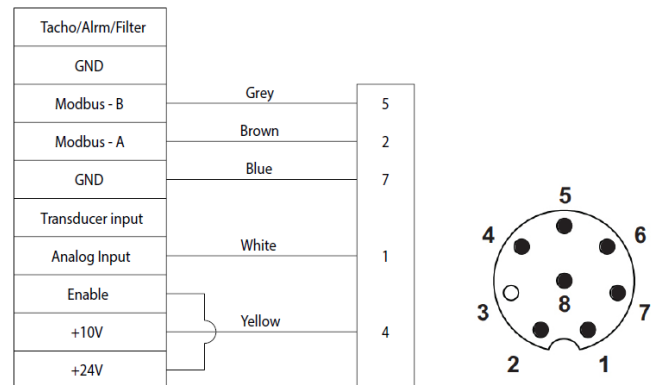

Power Supply

The end user must connect the power supply cable and the command signal to the control board, while the motor connection is already done by Nicotra Gebhardt.



As concerns the cable minimum section, check the requirements issued by the country of installation

PFP 1.35kW 1-Phase

Single Phase 220/240V $\pm 10\%$ @ 50/60Hz

The performance in the range [200V-264V] @ 50Hz/60Hz is always the same due to the PFC module inside the driver.

Min. and max. wire section:

Spring-loaded push-in clamp, suitable for:

0.2 mm² - 24 AWG up to 2.5 mm² - 12 AWG (stranded) or 4 mm² (solid) wire Use a bladed screwdriver, 0.6x3.5 mm max, to unlock.

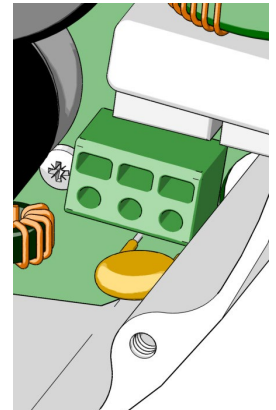
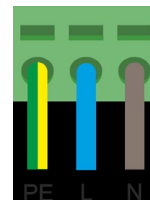

PFP 2.65kW 3-Phase

Three Phase 400V $\pm 10\%$ @ 50/60Hz

The maximum fan performance, within the nominal range of supply-voltage [360-440V], may be sensitive to the actual supply voltage. Whether the fan maximum speed is related to the supply voltage depends on the fan size and duty point.

Min. and max. wire section:

Spring-loaded push-in clamp, suitable for:

0.2 mm² - 24 AWG up to 6 mm² - 8 AWG (stranded) or 10 mm² (solid) wire use a bladed screwdriver, 0.6x3.5 mm max, to unlock.

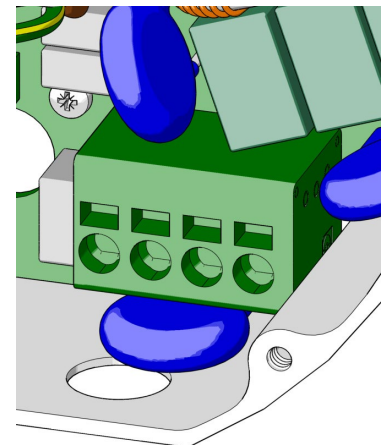
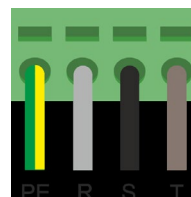

PFP 4kW-5.5kW 3-Phase

Three Phase 400V $\pm 10\%$ @ 50/60Hz

The maximum fan performance, within the nominal range of supply-voltage [360-440V], may be sensitive to the actual supply voltage. Whether the fan maximum speed is related to the supply voltage depends on the fan size and duty point.

Min. and max. wire section:

Spring-loaded push-in clamp, suitable for:

0.2 mm² - 24 AWG up to 6 mm² - 8 AWG (stranded) or 10 mm² (solid) wire use a bladed screwdriver, 0.6x3.5 mm max, to unlock.

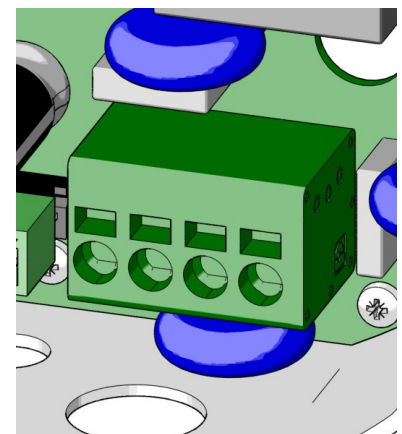
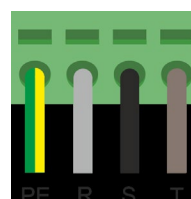

Control Board Connection

PFP 1.35kW 1-Phase

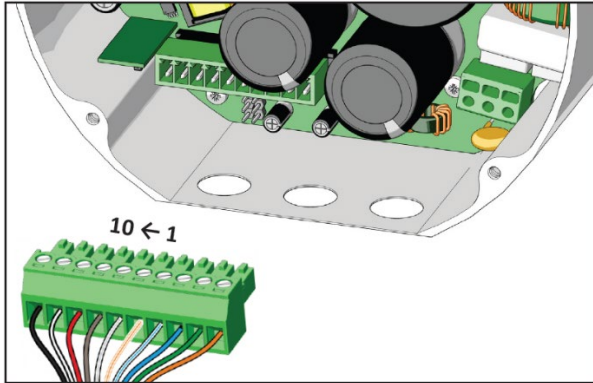

1	+24V
2	+10V
3	ENABLE
4	ANALOG INPUT
5	TRANSDUCER INPUT
6	GND
7	MODBUS - A
8	MODBUS - B
9	GND
10	TACHO/ALARM/FILTER

PFP 2.65kW 3-Phase

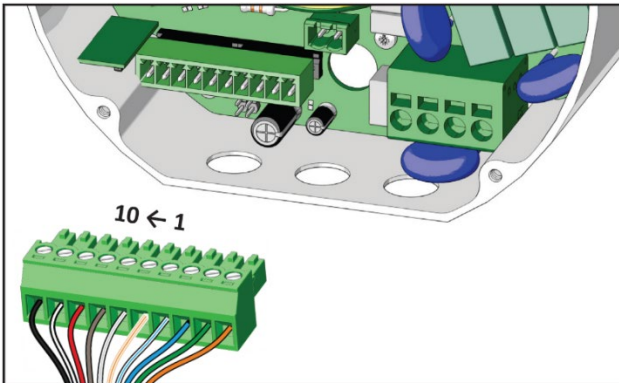

1	+24V
2	+10V
3	ENABLE
4	ANALOG INPUT
5	TRANSDUCER INPUT
6	GND
7	MODBUS - A
8	MODBUS - B
9	GND
10	TACHO/ALARM/FILTER

PFP 4kW-5.5kW 3-Phase

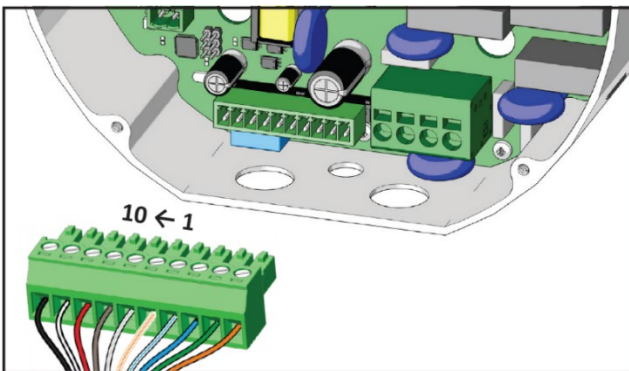

1	TACHO/ALARM/FILTER
2	GND
3	MODBUS - B
4	MODBUS - A
5	GND
6	TRANSDUCER INPUT
7	ANALOG INPUT
8	ENABLE
9	+10V
10	+24V

Min. and max. section:

- 0.13 - 1.31 mm² (26 - 16 AWG) solid or stranded cable.



Do not reverse the input signal or connect the +10V, 12V or +24V to signal ground. The driver could be damaged. Do not apply signals with voltage outside the indicated limits, the driver could be damaged.

Connection Details

In this paragraph are explained the feature and the possible connection of the control board. The control board terminals are opto-insulated.



The available features can be different depending on the fan model.

Analog

This is the driver default mode and the signal must be connected into the ANALOG INPUT and the reference to GND.

The analog input can accept also a PWM signal with $f > 1\text{kHz}$.

Do not use devices having the signal GND connected to the NEUTRAL cable of the power supply. The driver may be damaged or not functioning properly.



The available +10V power supply of the driver is intended to be used with a potentiometer of minimum 2KOhm, with a max absorbed current of 5mA. Any different devices connected to it could bring to an undesired functioning of the driver or of connected device.

ECEUK Ltd can provide a dedicated potentiometer: REGPOT code K43138.

Without using the STOP switch

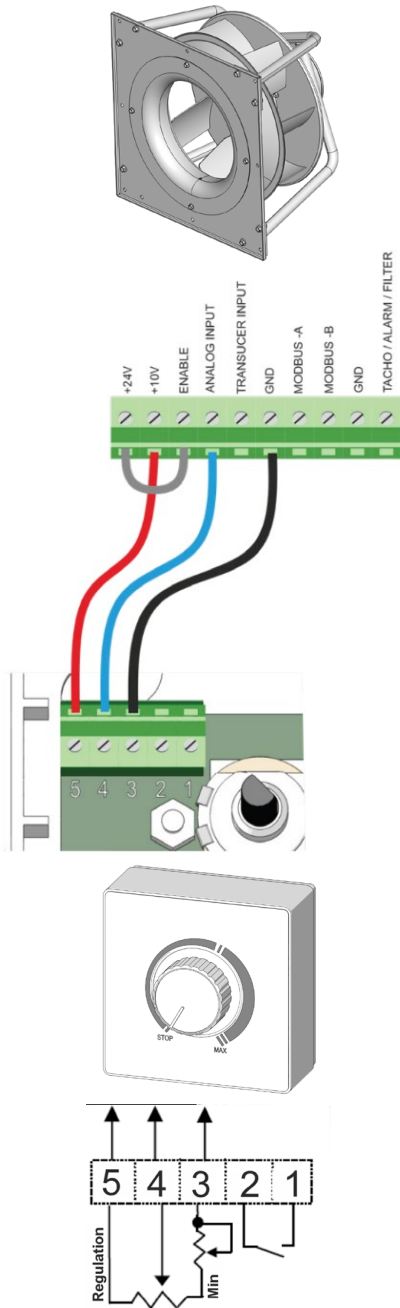

Using the STOP switch

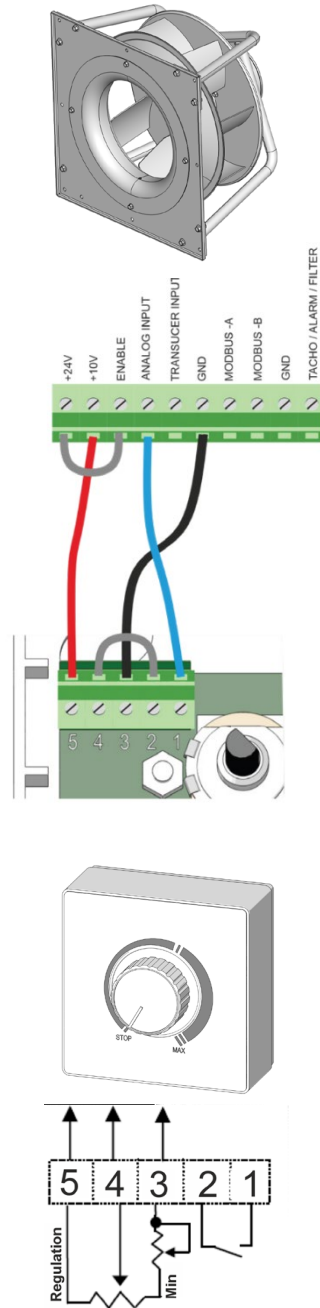

If two or more fans are installed in the same compartment and operated in parallel, the fans must start and stop at the same time.



An auto-restarting alarm occurs when a fan is forced to run forward (or backward) rotation with a speed higher than 150 rpm.

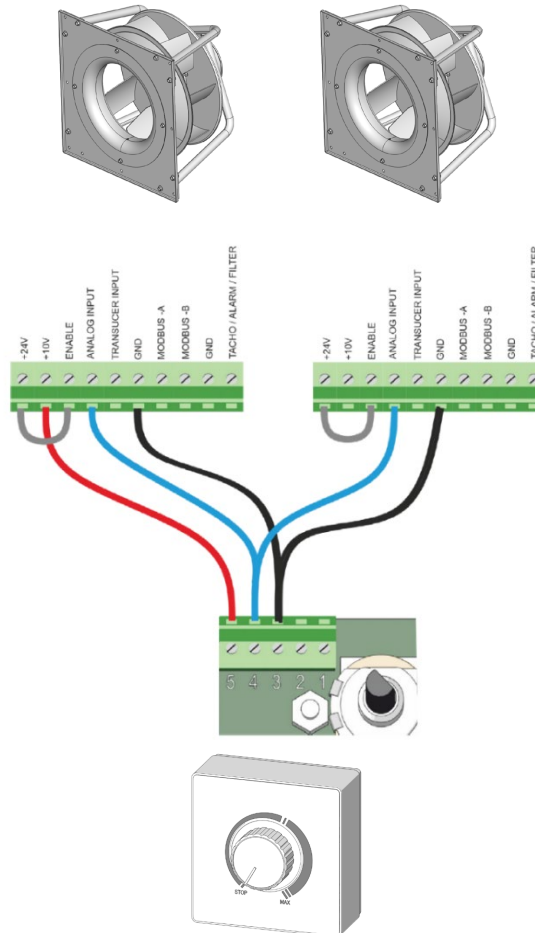

If an ext. 4-20mA device is used, it is necessary to add 0.1% precision resistances between the ANALOG INPUT and GND.

The value of the resistance can range from:

- 125 Ω -> V signal ranges from 0.5V to 2.5V.
- 500 Ω -> V signal ranges from 2V to 10V.

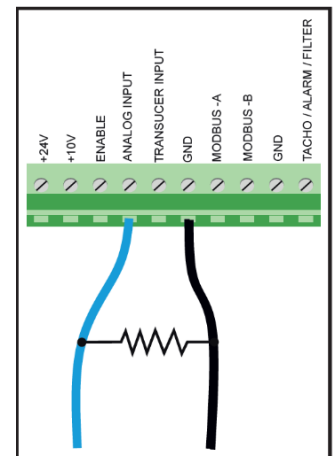

Modbus Communication

A Modbus RTU protocol is available on all the fan models.

The line must be connected to MODBUS-A, MODBUS-B and GND pins.

There are two possible Modbus connections:

1. During the fan functioning through any RS-485 serial connection
2. With the driver powered off through an UART serial connection

To connect the driver to a PC during the fan functioning, a USB to 485 converter can be used: K431F8.

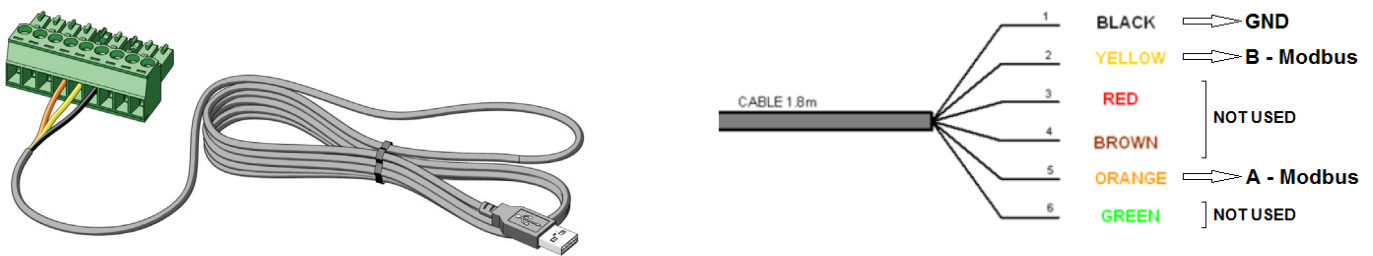

To connect OFFLINE the driver to a PC when the fan is powered off, a USB to UART converter can be used:

- K431A6 for 1-phase drivers and K431F7 for 3-phase drivers.
- A MOLEX connector "1" is used to connect the cable to the driver.

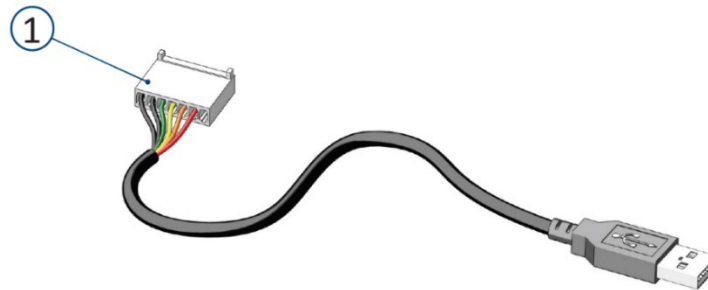

1-phase

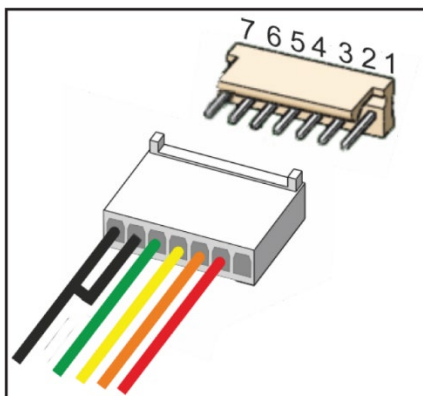

2-phase

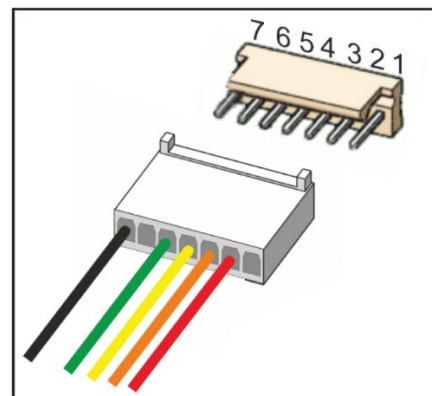

Specifications and drivers can be downloaded from Nicotra Gebhardt website:

<https://www.nicotragebhardt.com>

Enable Signal

The ENABLE signal allows the installation of the Start/Stop switch.

The fan runs when the ENABLE input is connected to the +10V or +24V power supply

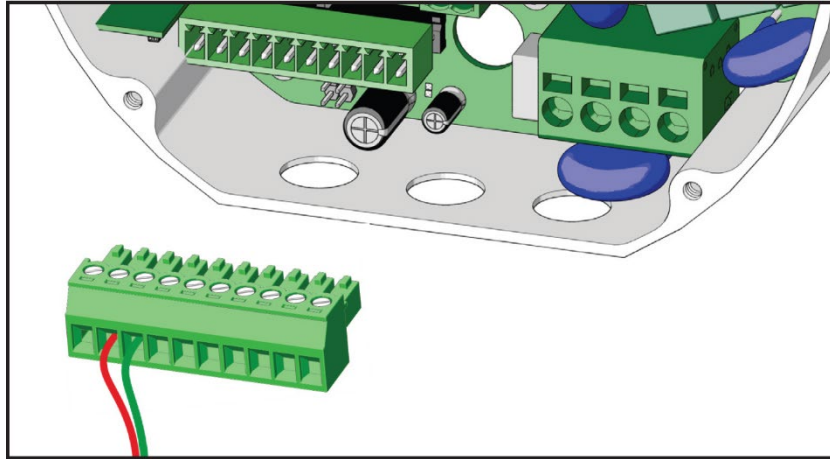

The status of the ENABLE input does not affect the Modbus Temporary modes.

The voltage provided on the “Enable” input is constantly measured in all the driver operating modes, and the value can be read in the Input Register 28.

The voltage provided on the Enable input does not affect the four “Modbus - Temporary” modes, where the fan is intended to be completely controlled, including its starting and stopping, via its serial interface.

This voltage is relevant in all the other operating modes: the modes relying on target values stored in fixed registers (Modbus – Fixed values) and the modes where an Analogue Input signal is used, plus the Master/ Slave mode.

In those modes which are sensitive to the Enable input, the fan starts only if the voltage on the Enable channel is above 5 V and stops when it’s brought to zero. An internal pull-down resistor brings the voltage to zero, if no voltage source is connected to the Enable channel.

This function cannot be disabled by software, but the Enable channel can be permanently connected with a jumper to either one of the internal voltage-sources: 10 V or 24 V.

When the Analogue Input signal is used, the driver needs both the digital input on the Enable channel and a signal higher than 0.5 V on the Analogue-Input channel, to start. In these modes, the fan can be stopped by removing the voltage on the Enable channel, by bringing the Analogue Input voltage below 0.5 V, or both. If it is not necessary turning on/off the fan with an external switch, a jumper can be inserted between clamps +24V and ENABLE. In case this jumper is not included, the fan will not start.

Pressure And Flow Meter

To provide a constant airflow, the PFP fan is provided with the volumeter pressure probes, which are then connected to transducer K43198 by means of K409A2 piping. This transducer is connected to the PID regulator incorporated into the driver, which is installed on the fan.

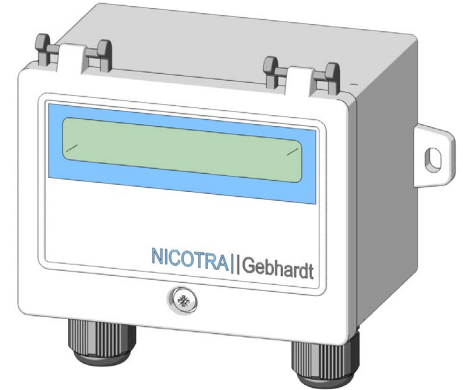

For a correct installation, follow the instructions supplied with the single components

An external transducer can be powered and connected to the driver. There are two possible connections depending on the kind of transducer used:

1. Open Control Loop Transducer.
2. Closed Control Loop Transducer.

ECEUK Ltd can provide a Pressure Transducer code K43198

If the transducer does not have its own control and it supplies a voltage signal [0, +10V] proportional to the measured variable, it is possible to use the tunable PID of the driver.

The signal must be connected to the TRANSDUCER INPUT.

If the transducer has its own PID control, the signal must be connected to the standard ANALOG INPUT.

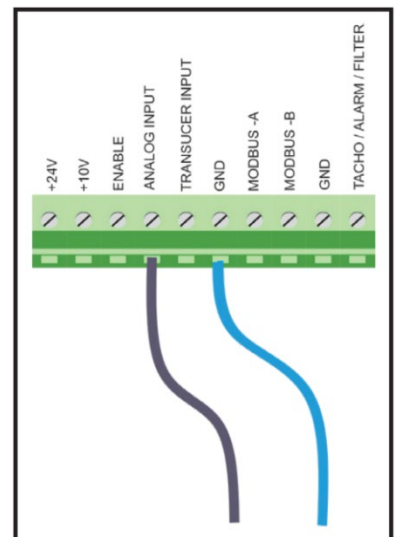
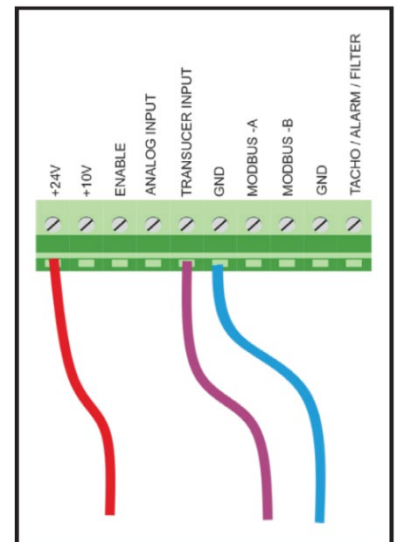

5 +24V AUX Power supply (for PFP 3-Ph only)

The +24V output can supply a max current of 50mA and it is able to drive the pressure transducer (code K43198).

Use an available ground pin on the board for powering devices.

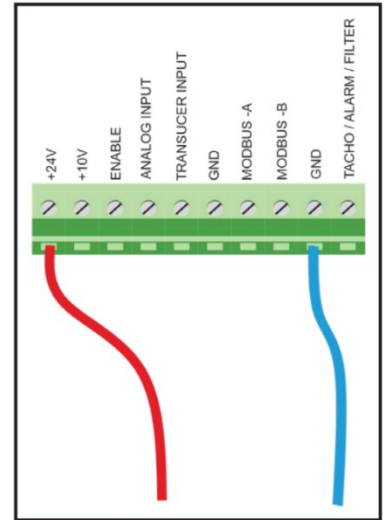
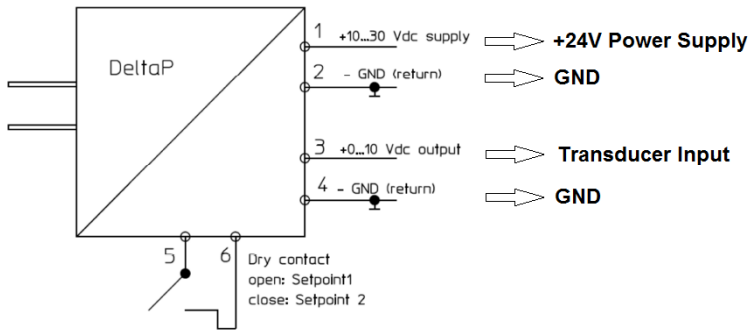

Relay 3-Phase



When the driver is powered off the relay is open -> the PCB label indicates C-NO.

During the functioning the relay is Normally Closed in No-Alarm condition and open in case of alarm.

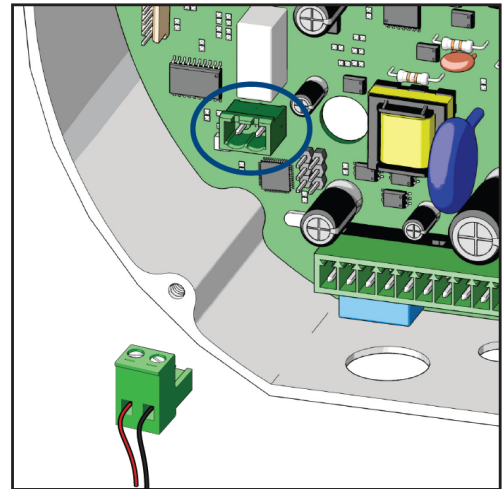
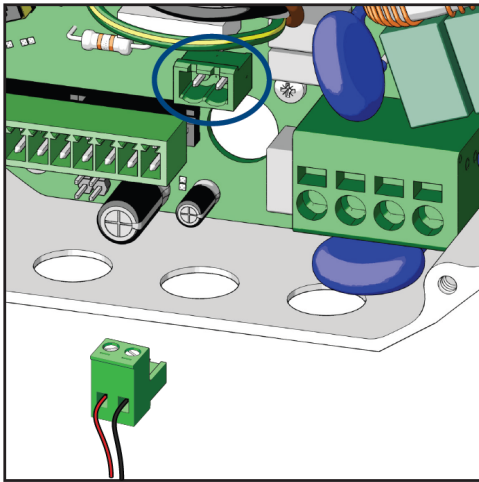

Min. and max. section:

- 0.33 - 2 mm² (22 - 14 AWG) solid or stranded cable.

Tachometric, Alarm and Filter Output

The analogue output channel is configured, by default, to provide a PWM tachometric output signal.

The tachometric output is a 0 to 10V PWM waveform at 1KHz.

$$Duty\ Cycle\ (Speed) = 10\% \frac{90\%(\text{Speed Real} - \text{Speed min})}{\text{Speed Max} - \text{Speed min}}$$

when the speed is equal or higher than the speed min and it is 0% when the speed is lower. The device reading the output must be connected to TACHO\ALARM\FILTER pin and GND.

The max current supplied of the output is 0.2mA



Remember that the *Speed_{Real}* is 0 whenever the required speed is lower than *Speed_{min}* unless the fan is in the dragging phase.

The same analogue output channel can be reconfigured, by changing the value in Holding Register 46), as a Digital Alarm Output

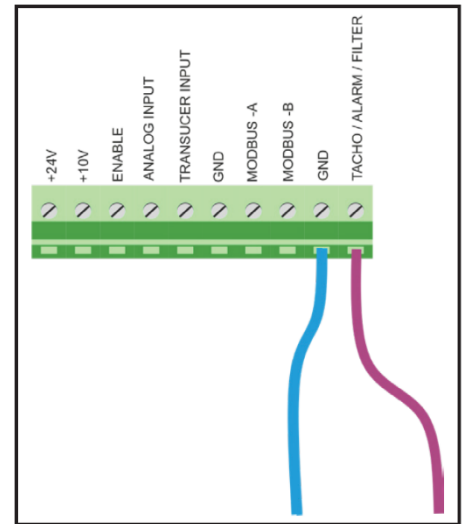

Input Impedances

Input Impedances		Feature available on
ANALOG INPUT	20 kΩ	PFP 1.35 kW 1-Phase
ENABLE ANALOG INPUT TRANSDUCER INPUT	200 kΩ	PFP 2.65 kW 3-Phase PFP 4 kW 3-Phase PFP 5.5 kW 3-Phase

PXA Unit Type & Performance Reference

Unit type reference

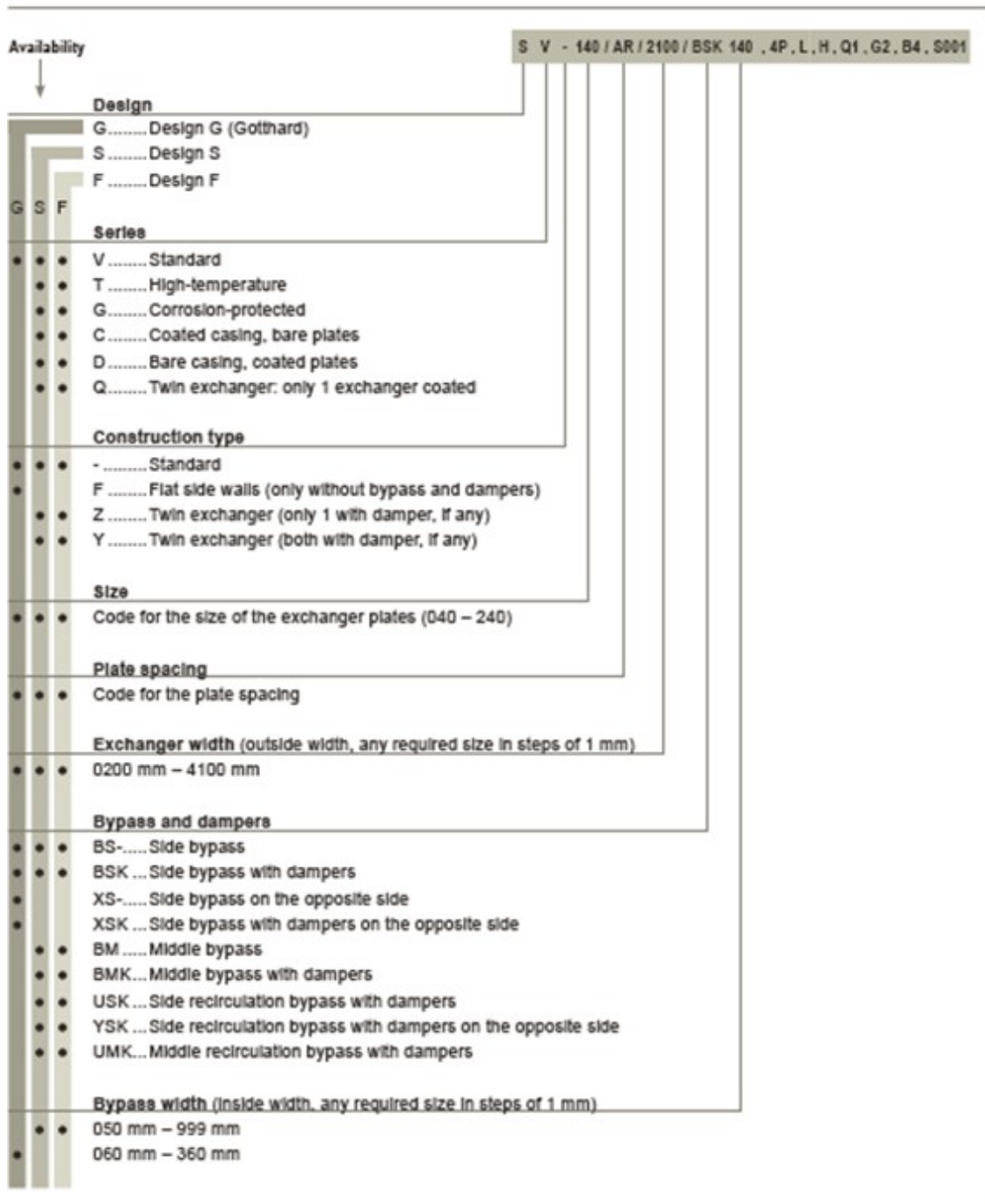

Availability			S V - 140 / AR / 2100 / BSK 140 , 4P , L , H , Q1 , G2 , B4 , S001
G	S	F	
			Leakage test
• •			2P Leakage test on 2 sides (air stream not flowing through the bypass)
• •			7P Leakage test on 2 sides (air stream through the bypass)
• •			4P Leakage test on 4 sides
			Horizontal Installation
• • •			L Horizontal Installation (for design G with dampers for widths up to 950 mm)
			Adapter for actuator
• • •			H Adapter for actuator
			Packaging
• •			Q1 Stronger packing
			Partitioned delivery
• • •			G2 Partitioned delivery
			Block of four, supplied loose
• •			B4 Supplied loose
			Special code
• • •			S001 .. Special code

The plate heat exchanger operates as a temperature moderator between the two air streams. The direction of the heat transmission is of no consequence, i.e. depending on the temperature difference between extract and fresh air, either heat recovery or coolth recovery will take place. This means the performance control of the plate heat exchanger is not necessary when the extract air temperature is identical to the desired room temperature. In this case, the outside temperature is always either heated or cooled through the plate heat exchanger in the direction of the set temperature. In many cases, however, heat gains are present in the ventilated space (people, machinery, lighting, solar, process plants) which increase the room temperature, so that the extract air temperature is higher than the set temperature. In this case, at full performance of the heat exchanger, check at which outside temperature heat-up begins, and if this cannot be tolerated, the performance of the heat exchanger must be controlled.

With the Plate Heat Exchanger the performance control through change of the mass flow ratio is simply and economically accomplished with the bypass. All Plate Heat Exchangers can therefore be supplied with integral bypass and control dampers. Exchanger and bypass width are automatically selected using a computer programme in a certain way that the pressure drop will be equal. Where a bypass is fitted will depend on the local conditions and also on the width of the exchanger. The bypass can be fitted either on the side of the unit or in the middle. The arrangement of further ventilation components after the bypass, e.g. air heater, moisture eliminator. It is important to take into consideration the fact that the velocity profile can be uneven.

This included with the Plate Heat Exchanger and the change of mass flow can be

Example

In an industrial building the room air is heated from 18 °C to 24 °C through lighting and machinery. The heat recovery figure Φ_2 is 66 %. At which outside temperature t_{21} is the space heated only by heat recovery without additional heating?

$$t_{21} = \frac{t_{22} - (\Phi_2 \cdot t_{11})}{(1 - \Phi_2)}$$

$$t_{21} = \frac{18 - (0.66 \cdot 24)}{(1 - 0.66)} = 6 \text{ °C}$$

At higher outside temperatures the hall is heated above the desired room temperature, this means the performance of heat recovery should be controlled.

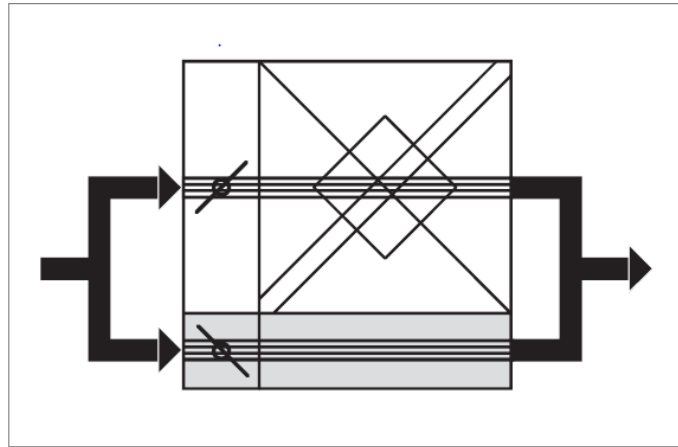

Fig. 6: The bypass is most effective for the control of performance.

There are two different options in order for the fitting of the bypass:

Bypass in the fresh air

Depending on where the damper is positioned, between 0% and 100% of the fresh air passes through the bypass. The extract air will always flow through the heat exchanger and it is cooled according to the fresh air flowrate. Within this arrangement, the cooling of the extract air and thus freezing can be avoided.

Bypass in the extract air

Something between 0% and 100% of the extract air will pass through the bypass. The fresh air will pass through the plate heat exchanger. The arrangement is recommended when the extract air is very dirty, as during summer operation the extract air does not pass through the plate heat exchanger.

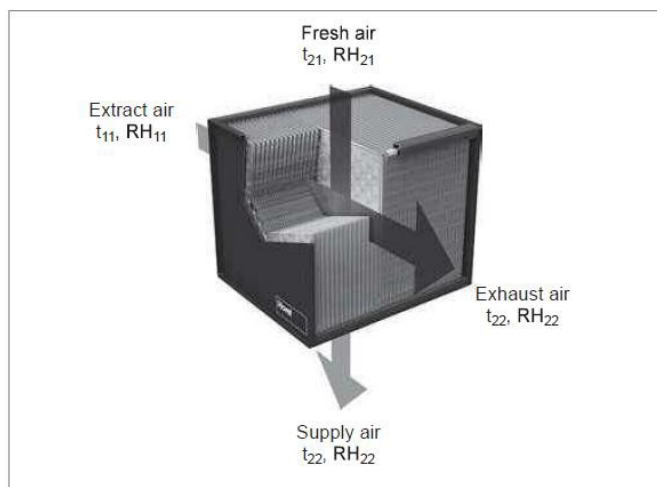

Fig. 7: Function diagram and air conditions

Design S

The crossflow plate heat exchanger for heat recovery, consisting of exchanger package and casing. The exchanger package consists of aluminium plates with pressed-in spacers; condensate drainage is possible in every direction, depending on the installation process.

The plates are connected by a fold, which gives a several fold material thickness at air entry and exit.

The corners of the exchanger package are sealed into especially rigid aluminium extrusions in the casing with a sealing compound. The side walls of Aluzinc sheet steel are bolted tightly to these extrusions.

All performance data is Eurovent-certified by Eurovent and RLT. Fry temperature efficiencies up to 80% can be achieved. The exchangers are resistant to up to 2500 Pa pressure difference between the air streams.

A hygiene certificate of ILH Berlin (institution of air hygiene) confirms the exchanger's suitability for use in general air handling systems as well as in hospitals.

- Series V (standard):
Aluminium plates, extruded aluminium sections and Aluzinc sheet steel; silicone-free; resistant to temperatures up to 90°C.
- Series T (high-temperature):
Aluminium plates, extruded aluminium sections and Aluzinc sheet steel; special sealing agent, resistant to temperatures up to 200°C.
- Series G (corrosion-protected):
All components (Aluminium plates, extruded aluminium sections and Aluzinc sheet steel); coated; silicone-free; resistant to temperatures up to 90°C
- Series C (coated casing, bare plates):
Bare aluminium plates, coated extruded aluminium sections and Aluzinc sheet steel; silicone-free; resistant to temperatures up to 90°C.
- Series D (bare casing, coated plates):
Coated aluminium plates, bare extruded aluminium sections and Aluzinc sheet steel; silicone-free; resistant to temperatures up to 90°C.
- Series Q (only 1 exchanger coated):
In series Q twin exchangers, one of the two exchangers corresponds to series V and the other exchanger is series G.

Depending on where the damper is positioned, between 0% and 100% of the fresh air passes through the bypass. The extract air will always flow through the heat exchanger and it is cooled according to fresh air flowrate. Within this arrangement. The cooling

Design F

- Series V (standard):
Aluminium plates, extruded aluminium sections and Aluzinc sheet steel; silicone-free; resistant to temperatures up to 100°C.
- Series T (high-temperature):
Aluminium plates, extruded aluminium sections and Aluzinc sheet steel; special sealing agent, resistant to temperatures up to 200°C.
- Series G (corrosion-protected):
All components (aluminium plates, extruded aluminium sections and Aluzinc sheet steel; silicone free; resistant to temperatures up to 100°
- Series C (coated casing, bear plates):
Bear aluminium plates, coated extruded aluminium sections and Aluzinc sheet steel; silicone-free; resistant to temperatures up to 100°C.
- Series Q (only 1 exchanger coated):
In series Q twin exchangers, one of the two exchangers corresponds to series V and the other exchanger is series G.

Construction types

A distinction is made between the following construction types:

- Individual exchangers (standard)
- Twin exchangers: The plate heat exchangers are supplied individually and are only assembled into a twin exchanger in the central air conditioning unit.

Options

- A side or middle bypass suited to the exchanger package is built into the casing.
- A side or middle recirculation bypass suited to the exchanger package is built into the casing (in the exhaust air stream or in the supply air stream, as desired)
- Control dampers are positioned on the casing before the exchanger face and the bypass; resistant to temperatures up to 80°C. These consist of galvanised sheet steel (powder-coated for designs G and C). The geared drives are high-grade plastic. Leak tightness class 2 in accordance with EN 1751.
- The exchanger is suitable for horizontal installation (plates arranged horizontally).
- Leakage test.
- Adapter for actuator for inside drive of the control dampers.

Leakage Test

Plate Heat Exchangers are not 100% leak-proof unless special measures are taken. Yet, by additional sealing we can guarantee that the exchanger is delivered watertight in the tested installation position.

Depending on requirements, the exchangers can be additionally sealed on two sides (2P = one air stream) or four sides (4P = both air streams).

The leakage test is not available for exchangers of series T.

“Exchangers for horizontal installation should always be checked on all four sides”

Horizontal installation

The plate heat exchanger will normally be installed in such a way that the plates are in fact vertical. Horizontal installation is always a possibility, when the following is considered:

- There is a higher icing-up hazard because condensate can remain on the plates.
- Due to uncontrolled condensate drain a condensate drip tray should be installed below the exchanger.
- Condensate drops can be carried along with air flow; (drop eliminator recommended)
- A four-side leakage test is recommended.
- Install plate heat exchangers of designs F and P in such a way that the spacing ribs stand upwards.
- To increase stability, supports are fitted in the exchanger package.
- Unless otherwise expressly requested, the side bypass is positioned on top.

“For horizontally installed exchangers the width B in the unit type reference becomes the exchanger height”

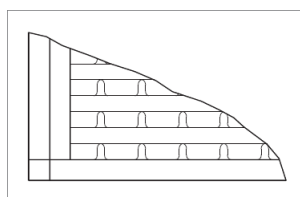

Fig. 22: Spacing ribs standing upwards

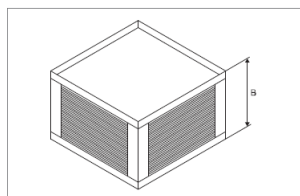

Fig. 23: Schematic view of a plate heat exchanger installed in horizontal position

Adapter H for actuator

Using the adapter, the dampers (bypass or recirculation dampers) can be driven inside a ventilation unit with conventional rotary actuators. The maximum transmittable torque is 20 Nm.

The adapter is screw-fastened on the gear wheel housing. For this, the plate flange is cut out above a damper gear wheel so that the adapter gear wheel can be put on directly. The adapter is available in series V and G.

For installation take into consideration the following:

- The adapter is positioned above a damper gear wheel, approximately in the middle of the plate heat exchanger.
- Depending on the exchanger's installation position, it must be checked if there is enough space for the adapter.
- When installing the actuator ensure that the electric cables do not obstruct the damper motion.
- The adapter can also be retro-fitted on a plate heat exchange.



Fig. 25: Using the adapter Hoval dampers can be driven with conventional rotary actuators.

Design S	050	070	170					
Design F	100	120	140	160	200	240		

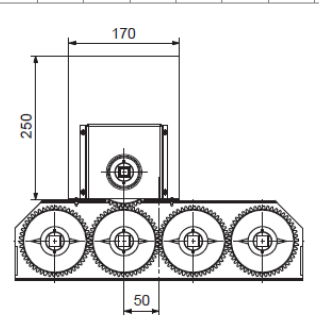

Design S	040	060	085	100	120	140	200	240
Design P	100	200						

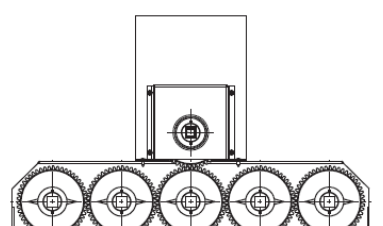

Table 5: Adapter dimensions (in mm) and positioning on the damper with even or odd number of gear wheels

PXA Unit Fan Type & Speed Control

RLM Technical Information

Product Description



The fans are intended for incorporation into equipment and do not have their own contact protection fitted as standard. The appropriate protective measures are to be taken in accordance with DIN EN ISO 13857

The centrifugal fans RLM/RLC, optimised for use without scroll. Direct drive with mounted standard motor construction B3/B5 or a permanent magnet excited synchronous motor (PM motor). The centrifugal impeller with backward-curved blades is attached directly to the motor shaft. Certain fans in the RLM/RLC range have an integrated frequency inverter.

RLM E6 / G6 / E3 / 56 / 53 / 55

Motor impeller with inlet cone (E3/53), motor block and base frame (E6/G6/55/56), installed and adjusted at the factory.

RLC E6: AMCA certified series, identical to RLM E6

RLM E3 / 53

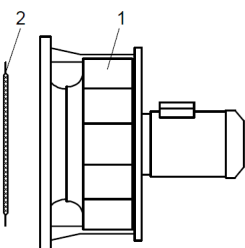

RLM 55

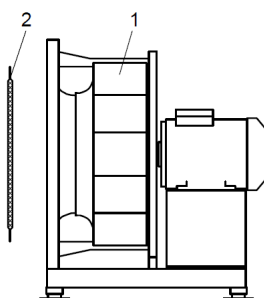

RLM E6 / G6 / 56 ; RLC E6

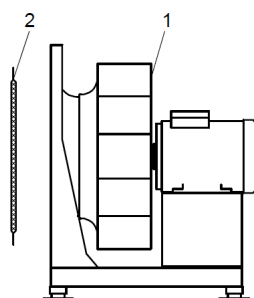

1. Fan
2. Inlet guard

Technical Data

Technical data and the permissible limits are to be taken from the type plate, the technical datasheets or the appropriate technical catalogue and must be adhered to.

Authorised use

The fans are intended for the transport of dust-free air and other non-aggressive gases or vapors.

Permissible media temperatures:

Range	RLM/RLC
Temperature	-20°C to +40°C

Maximum ambient temperature at the drive motor: +40°C.

CAUTION

Ambient temperature with the Danfoss FCP-106 mounted frequency inverter: -10 °C to +40 °C
Any installation deviating from the above shall be considered unauthorised.



ECEUK Ltd will not be responsible for any injury to personnel and/or material damage resulting from any deviations from the above!

Should any control equipment utilising electronic components be employed (e.g. frequency inverter), the recommendations of the manufacturer are to be observed concerning the avoidance of electromagnetic radiation (EMC) (through suitable earthing, cable lengths, cable screening, etc.).

Improper Use

An improper installation would be e.g. the transporting of:

- media with unacceptable high or low temperatures
- aggressive media.
- very dusty media.

unauthorised operation

- No operation above the indicated rpm (see type plate, data sheet)!
- No operation at rpm ranges with increased vibration (resonance)!
- No operation at rpm ranges out of permitted fan curve area (instability of flow pattern)!
- No operation if fan becomes polluted!

The results are: Bearings damage, corrosion damage, loss of balance, vibration, deformation, abrasion damage.

CAUTION

Prevent dynamic stress on the impeller, avoid frequent load changes!



Danger points:

There can be injury to personnel and material damage through impeller breakage, shaft breakage, fatigue failure, fire from spark creation.

Important Information

These Fans are of state of the art design and comply with the requirements for health and safety of the EU Machinery Directive.

Nicotra Gebhardt Fans offer a high level of operational safety and a high standard of quality which is guaranteed through a certified Quality Assurance System (EN ISO 9001).

All fans leave the factory after being subjected to testing and are provided with a test seal.

All fans however can be dangerous,

- if they are not installed, operated and maintained by trained personnel
- if they are not used for approved applications.

This can endanger the life and limbs of personnel, provoke material damage to buildings and equipment and influence the use of the product.



Attention!

These Operating Instructions must be read and observed by all personnel engaged on works involving fans!

Operating Instructions

- Describe the approved applications for the fans and protect against misuse.
- Contain safety notes which must be closely observed.
- Warn of dangers which can exist even with correct applications.
- Give important information on safety and the economic use of the fan while ensuring the full benefits of the product are available.
- Are to be complemented with the trade and national Standards, Regulations and Directives.

ECEUK Ltd accepts no responsibility for damage or breakdowns which can be traced back to non-observance of the Operating Instructions.

The manufacturer's guarantee does not apply following unauthorised and unacceptable conversions and alterations to the fan.

There is no responsibility accepted for resultant damages!

PFP Technical Information

Production Description

The PFP is a backward curved blade fan equipped by an external permanent magnet rotor motor. The rotor magnets are made by rare earths (NdFeB) that strongly reduce the motor dimension and, therefore, the fan obstruction. The motor shape itself has been chosen for increasing the airflow inside the fan scroll.

The Driver is fully integrated into the motor and it drives the motor through a sensor less algorithm. The single phase driver is equipped with an active PFC (Power Factor > 0.95 in any state of operation).

The Fans of series PFP combine high energy efficiency and low noise level. Thanks to the “EC” (electronic commutation) motors, their electronics integrate speed control and protecting system. This reduces the number of different components required to provide these functions, compared to fans with traditional motors.

The main feature of EC-motor is operating without slip losses, which allow consuming significantly less power than conventional AC motors.

This occurs at all speed levels, especially with partial load operation. The EC complete drive system (i.e. the combination of the permanent-magnet motor with its electronic driver) has a much higher energy efficiency, in comparison with a drive system based on a conventional AC motor.

Features:

- Supply voltage 220V-240V or 400V -3Ph +/- 10% (50/60Hz)
- Sinusoidal Sensor less control
- Integrated active Power Factor Controller or Single-Phase units
- Simple cable connection with cage clamps
- Integrated Modbus RTU interface
- Integrated analogue interface 0-10V
- Tachometric output available

Performance:

- Internal PID available
- Soft start
- Adjustable limits and operating mode
- Self-protecting strategies implemented
- High efficiency
- NTC bypassed during operation
- PFC disabled at stop
- Available with Maximum Power input 1.35k-1Ph, 2.6kW-3Ph, 4kW-3Ph or 5.5kW-3Ph
- Power Factor >0.95 on models with A-PFC

Protection:

- Missing motor phase protection
- Short circuit protection
- Overload protection
- Overheat protection
- Impeller blocking protection
- Safe Operating Area (speed, power and current limitation)

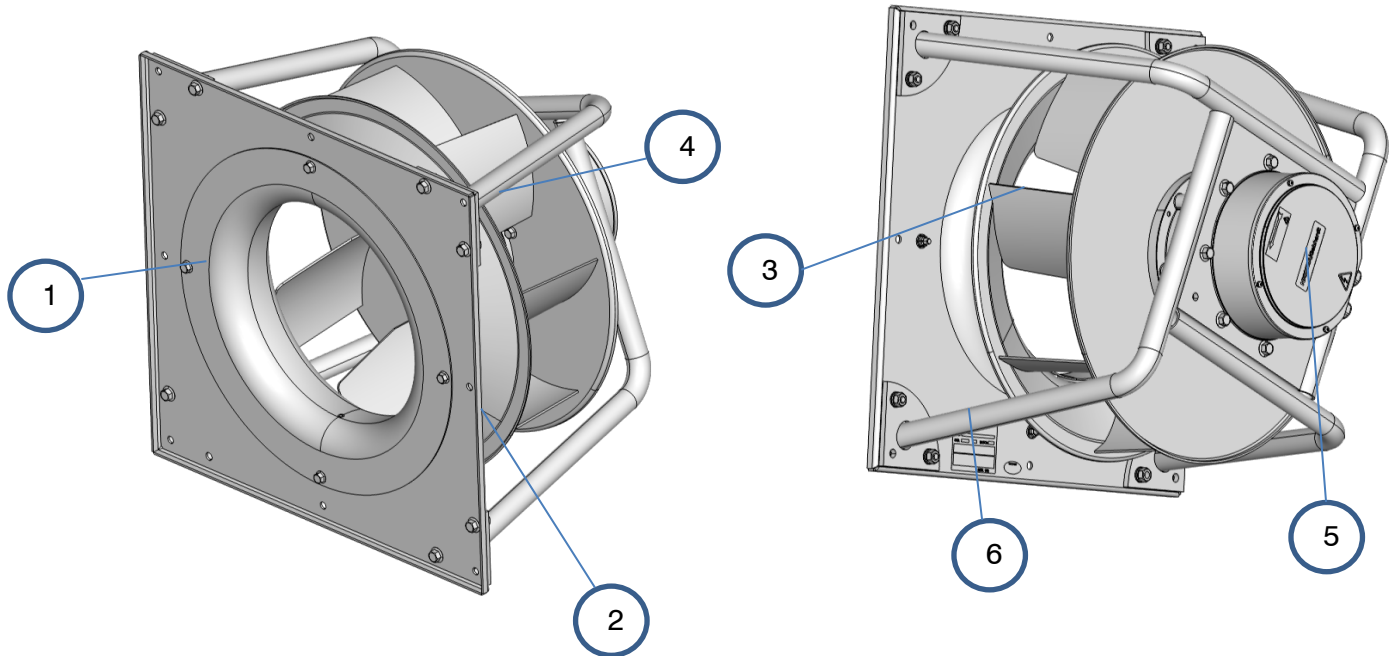

REF.	DESCRIPTION
1	Inlet Port
2	Outlet Port
3	Rotor (forward-curved blades)
4	EC motor
5	Driver
6	ID plate

Technical Data

Size	Motor code	Driver code	Driver phases	Abs. curr. (A)	Abs. pow. (W)	Min. temp. (°C)	Max. temp. (°C)	IP class protection
280-A	1416F0	1431F2	1 Ph	5.72	1363	-20°C	+40°C	IP 55
280-A	1416F8	1431F3	3 Ph	2.07	1320	-20°C	+40°C	IP 55
315-A	1416F0	1431F2	1 Ph	5.82	1365	-20°C	+40°C	IP 55
315-A	1416F8	1431F3	3 Ph	2.34	1500	-20°C	+40°C	IP 55
355-A	1416F1	1431F2	1 Ph	5.74	1378	-20°C	+40°C	IP 55
355-A	1416F6	1431F3	3 Ph	3.24	2110	-20°C	+40°C	IP 55
400-A	1416F1	1431F2	1 Ph	5.74	1347	-20°C	+40°C	IP 55
400-A	1416F5	1431F3	3 Ph	4	2600	-20°C	+40°C	IP 55
450-A	1416F1	1431F2	1 Ph	5.71	1327	-20°C	+40°C	IP 55
450-A	1416F7	1431F3	3 Ph	3.64	2370	-20°C	+40°C	IP 55
450-A	1416H7	1431F9	3 Ph	4.5	2860	-20°C	+40°C	IP 54
450-B	1416K5	1431G5	3 Ph	8.7	5760	-20°C	+40°C	IP 54
450-C	1416L1	1431G5	3 Ph	6.3	4150	-20°C	+40°C	IP 54
500-A	1416F2	1431F2	1 Ph	5.82	1390	-20°C	+40°C	IP 55
500-A	1416H5	1431F9	3 Ph	5.96	4122	-20°C	+40°C	IP 54
500-B	1416K6	1431G5	3 Ph	8.7	5820	-20°C	+40°C	IP 54
500-C	1416K6	1431G5	3 Ph	7.5	4840	-20°C	+40°C	IP 54
560-A	1416H6	1431F9	3 Ph	5.86	3980	-20°C	+40°C	IP 54
560-B	1416K7	1431G5	3 Ph	8.3	5600	-20°C	+40°C	IP 54
560-C	1416L0	1431G5	3 Ph	8.4	5515	-20°C	+40°C	IP 54
630-A	1416H8	1431F9	3 Ph	5.14	3500	-20°C	+40°C	IP 54
630-A	1416K8	1431G5	3 Ph	7.9	5200	-20°C	+40°C	IP 54
710-A	1416K9	1431G5	3 Ph	6.6	4390	-20°C	+40°C	IP 54

Dimensional Drawings

The four main dimensional parameters (A, B, C and D) are illustrated in the scheme and the table below, according to the different sizes.

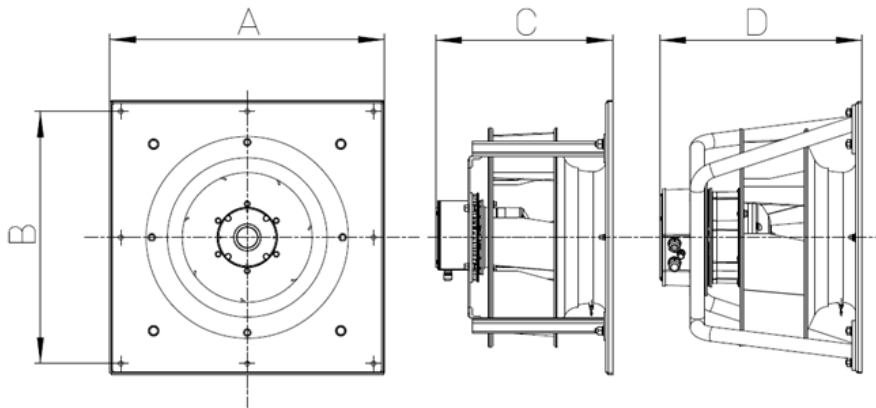

Size	A	B	C	D
280-A	400	350	309	-
315-A	500	450	329	-
355-A	500	450	354	-
400-A	500	450	379	-
450-A	630	580	406	-
450-A	630	580	-	469
450-B	630	580	-	461
450-C	630	580	-	454
500-A	630	580	440	-
500-A	630	580	-	503
500-B	630	580	-	491
500-C	630	580	-	483
560-A	800	750	-	539
560-B	800	750	-	528
560-C	800	750	-	520
630-A	800	750	-	573
710-A	960	910	-	627

Operating Modes and Setting Options

Depending on the fan model, there are 4 possible Operating Modes and for each mode 3 possible Setting Options.

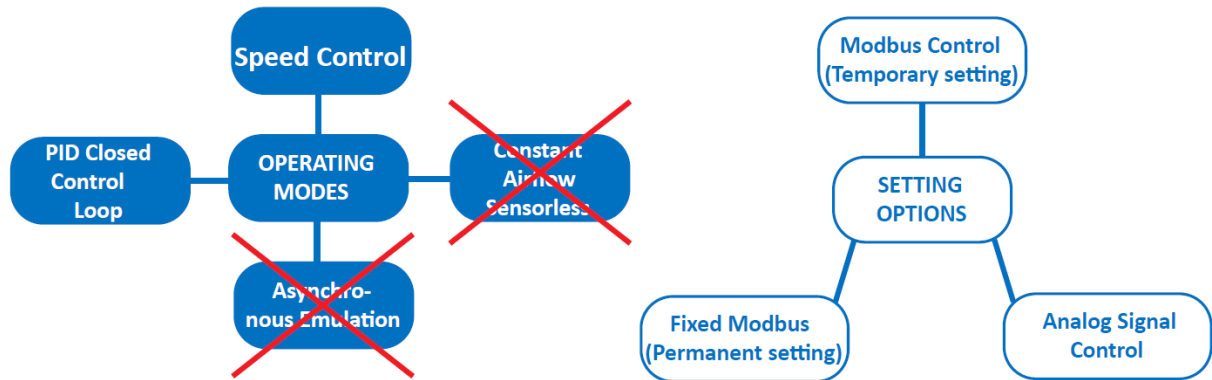

The operating mode “Constant Airflow” is not available for PFPs. Setting the fan in one of the three Constant Airflow modes could make it turn in an unknown and/or uncontrollable manner.



The algorithm related to the operating mode "Asynchronous Emulation" does not produce significant differences on PFPs in comparison to the operating mode “Speed control”. Therefore, its use is not recommended.

The operating modes and the setting options can be chosen by modifying the INPUT TYPE Holding Register 34.

PFP Speed Control

Analog Speed Control

(INPUT TYPE = 1 Default factory setting)

Through this setting the fan speed is proportional to the analog voltage input. The fan speed is limited by the Safe Operating Area, therefore, depending on the fan working point, the fan could be no more able to increase the speed coherently to the set voltage value.

To avoid the loss of signal dynamic, a speed limit rescaling is necessary by modifying the value of the Max Speed Holding Register 2. It is also possible to rescale the min Speed by modifying the Holding Register 1. The analog signal can be read from the Input Register 14.



For more details refer to the ANNEX -> Analog Signal Considerations

The MAX and min speed default values are in function of the fan sizes.



The minimum speed holding register cannot be modified for 1.35kW 1-Ph.

Modbus Temporary Speed Control

(INPUT TYPE = 0)

Through this setting the fan runs at the speed defined by modifying the Holding Register 66.

The setting is maintained meanwhile the fan is powered on and it is lost when the fan is powered off.

Modbus Fixed Speed Control

(INPUT TYPE = 2)

Through this setting the fan runs at the speed defined by modifying the Holding Register 21.

The setting is permanent and fan starts at the defined speed each time it is powered on.

Speed Control Curves Example

The following figures show a set of performance curves at different speed settings limited by the fan max working limit curve

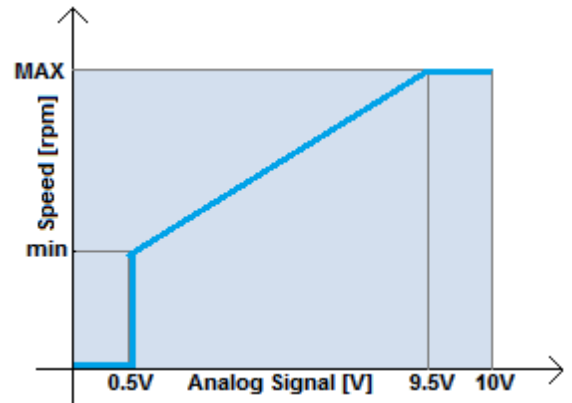
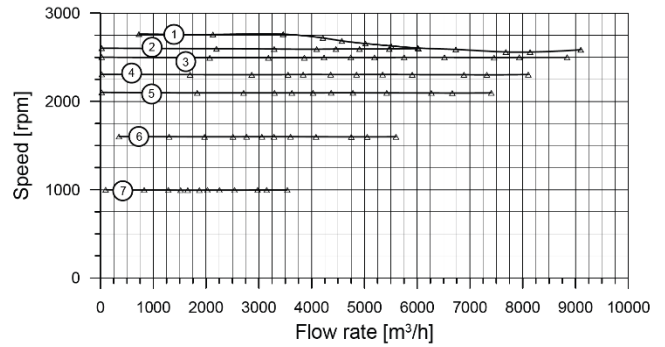
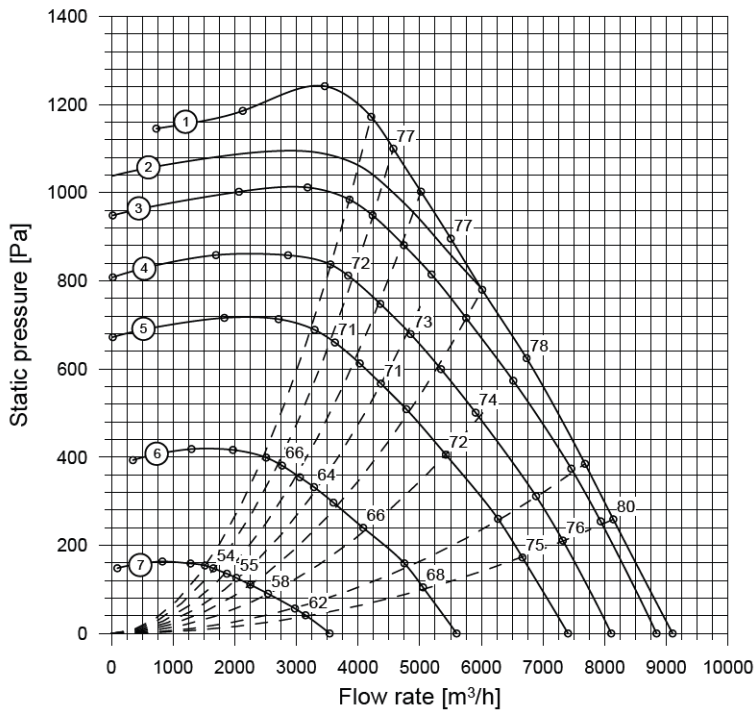

PFP Constant Air Flow

This operating mode is not available for PFPs.

PFP Asynchronous Emulation

This operating mode is not available for PFPs.

PFP PID Closed Control Loop

Through this setting the fan can work in a PID closed control loop where the measured process variable is connected to the TRANSDUCER INPUT that can be monitored Through the Input Register 31. and it must be in the range of [0,10V]. The PID mode can be therefore used with temperature probes, pressure transducer, CO/CO₂ detectors, etc.

The parameters to set are:

- KP = Proportional Gain -> Holding Register 51
- KI = Integral Gain -> Holding Register 52
- KD = Derivative Gain -> Holding Register 53
- Time = TPID -> Holding Register 54

The following equations represent the simplified PID code:

$$E_{\text{Error}}(n) = (R_{\text{eference}} - M_{\text{easure}})$$

$$P_{\text{roportional}} = K_P * E_{\text{Error}}(n)$$

$$I_{\text{ntegral}}(n) = I_{\text{ntegral}}(n - 1) + K_I * E_{\text{Error}}(n) * T_{\text{PID}}$$

$$D_{\text{erivative}} = \frac{K_D * (E_{\text{Error}}(n) - E_{\text{Error}}(n - 1))}{T_{\text{PID}}}$$

$$E_{\text{Error}}(n - 1) = E_{\text{Error}}(n)$$

$$I_{\text{ntegral}}(n - 1) = I_{\text{ntegral}}(n)$$

$$C_{\text{ontrol}} = P_{\text{roportional}} + I_{\text{ntegral}}(n) + D_{\text{erivative}}$$

PFP Analog ref. PID closed control loop

(INPUT TYPE = 10)

In this mode the PID reference is given by the analog signal present at the ANALOG INPUT that can be monitored through the Input Register 29.

PFP Modbus temporary ref. PID closed control loop

(INPUT TYPE = 11)

In this mode the PID reference is defined by modifying the Holding Register 66.

The value of the reference is expressed in steps of 0.1 Volt (therefore the register ranges from 0 to 100). The PID error is calculated in the following way:

$$E_{\text{Error}} = (\text{ModbusReg66} - \text{ANALOG}_{\text{input}})$$

PFP Modbus Positive / Negative Feedback

Depending on the application it could be necessary to invert the feedback behavior.
Through the Holding Register 31 it is possible to multiply by -1 the PID error.

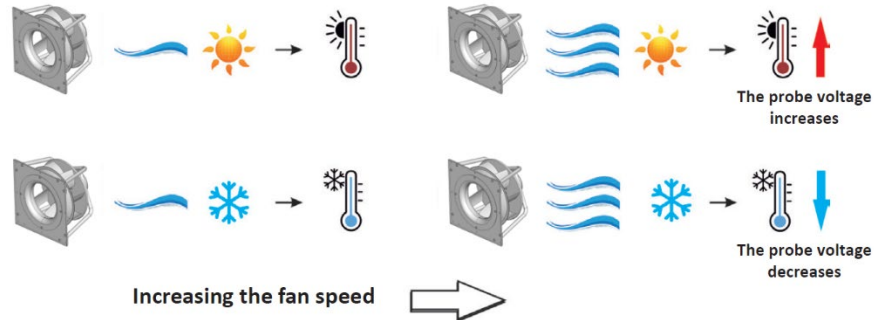

When the register is set to 0 -> $Error = (R_{eference} - M_{easure})$

When the register is set to 1 -> $Error = (M_{easure} - R_{eference})$

PFP Changing The Operation Mode

Here are shown the actions passing from one operation mode to another one.

ACTION	ACTIONS A	ACTIONS B
Temporary Setting -> Fixed Setting	The fan must follow the target corresponding to the value stored the related register.	Fan is put in stop mode and after the data are saved the fan follows the target corresponding to the value stored into the related register.
Fixed Setting -> Temporary Setting	The fan must stop waiting for a new register 66 value.	The fan must stop waiting for a new register 66 value.
Temporary Setting -> Analog Signal	The fan must follow the target corresponding to the analog value at the inputs.	Fan is put in stop mode and after the data are saved the fan follows the target corresponding to the analog value.
Analog Signal -> Temporary Setting	The fan must stop waiting for a new register 66 value.	The fan must stop waiting for a new register 66 value.
Fixed Setting -> Analog Signal	The fan must follow the target corresponding to the analog value at the inputs.	Fan is put in stop mode and after the data are saved the fan follows the target corresponding to the analog value.
Analog Signal -> Fixed Setting	The fan must follow the target corresponding to the value stored the related register.	Fan is put in stop mode and after the data are saved the fan follows the target corresponding to the value stored into the related register.

PFP Volumeter Measurement System For Volume Flow Rate

The Volumeter system is a measurement device for the volume flow rate of an operating fan.

A correct and easy measurement of the fan volume flow can satisfy a variety of requirements, from acceptance testing of a new plant, at start-up time, to the automatic control of complex systems.

The Volumeter system differs from other measurement devices, like Wilson grids and Venturi-meters, because it does not need a long, regular-section piece of straight duct. It can be easily integrated in the structure of a standard A.H.U. without special modifications.

A complete Volumeter system is made of two parts:

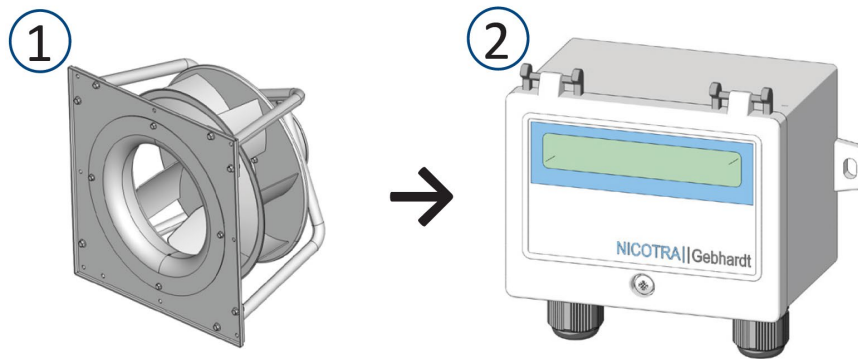

1. A modified fan, with special pressure probes located on each inlet nozzle.
2. A Pressure Transducer code K43198, located close to the fan and connected with pipes to the fan and with an electrical cable to a dedicated display (as shown in the following scheme).

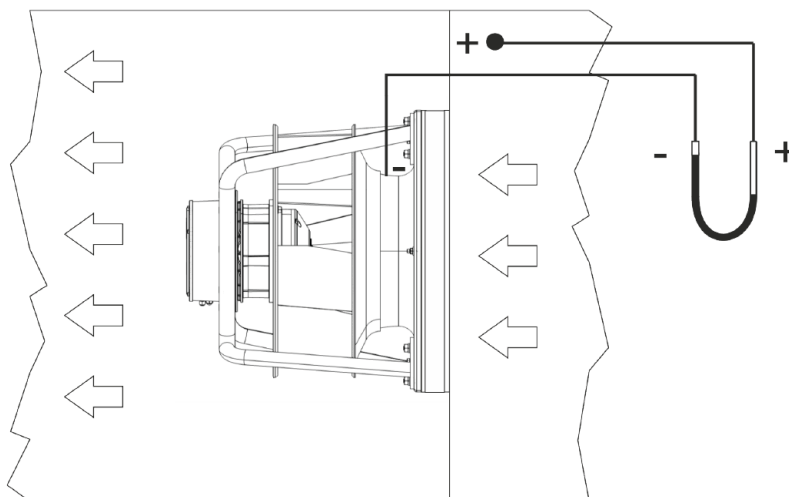

The Volumeter device is based on the Venturi principle, sensing the suction which is produced, in the throat section of the fan inlet nozzle or bell-mouth, by the airflow entering the fan.

The achievable precision from a complete and appropriately calibrated system (+/-5%) corresponds to the level of precision normally required for industrial measurements on a running plant.

The characteristic architecture of the Volumeter system allows the use of those components only needed by the specific application, limiting the cost of the equipment when the design requirements are simpler. The three components described above may be used or not, according to the functionalities required from each measurement system.

PFP How To Calculate The Volume Flow Rate From The Pressure Probe

The following analytical equations show how to calculate the value of the volume flow rate from the value of the probe pressure Δp and vice versa. Values of Δp are given in Pa, while values of flow rate Q are expressed in m³/h.

Analytical expression to determine flow rate values from the pressure values, which can be read on the pressure-probe transducer:

$$Q = C * \sqrt{\frac{1.2}{\rho}} * \sqrt{\Delta p}$$

where:

Q = volume flow rate [m³/h]

Δp = pressure value, read on the manometer [Pa]

ρ = air density [kg·m⁻³] (1.2 at 20°C, 50% r.h. and 1013.2 hPa)

C = dimensional constant, from the following table on this page.

Analytical expression to predict pressure probe manometer readings from the corresponding flow rate values:

$$\Delta p = \frac{\rho}{1.2} * \left(\frac{Q}{C}\right)^2$$

where:

Q = volume flow rate [m³/h]

Δp = pressure value, read on the manometer [Pa]

ρ = air density [kg·m⁻³] (1.2 at 20°C, 50% r.h. and 1013.2 hPa)

C = dimensional constant, from the following table on this page.

The K value to be inserted inside the device is:

$$K = C * \sqrt{\frac{1.2}{\rho}}$$

As you can see, if the measurement is taken at standard air density, the square root assumes a unit value and $K = C$.

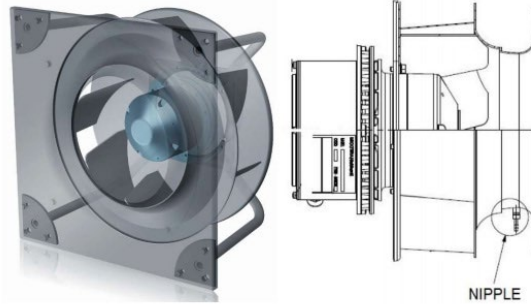

The Probe Calibration Constant C has different values, according to the fan type and size, as shown in the following table:

PFP	C _{PFP}
PFP_280	84
PFP_315	107
PFP_355	134
PFP_400	170
PFP_450	218

PFP	C _{PFP}
PFP_500	268
PFP_560	336
PFP_630	425
PFP_710	540

PFP Filter Alarm

This feature is useful when the speed of the fan is not directly set by the user as fans set in Constant Airflow Asynchronous Emulation or PID mode.

The alarm is active when a speed threshold is overtaken (5V or 10V depending on the fan model).

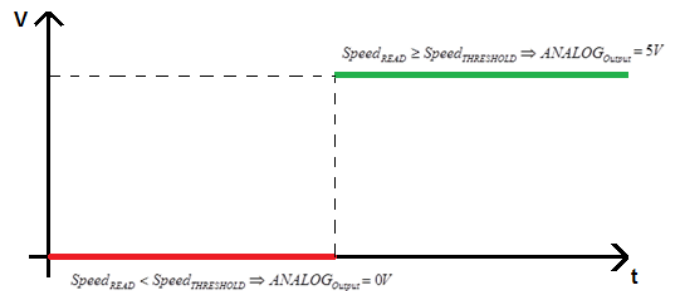
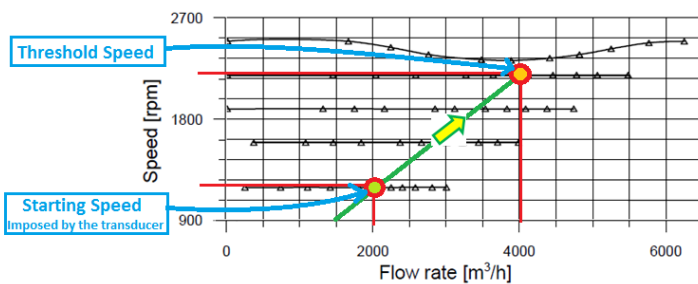

To activate this feature, the Holding Register 46 must be set at value 2 and the required Speed Threshold value must be set into the Holding Register 55. The digital output of the driver changes its status (see above figure).

PFP Change of limits

The Min Speed values set as default are higher than the possible values that can be introduced in this register.

Two limitations are active for this register:

Absolute minimum speed (Hardcoded)

The absolute minimum value that can be set in this register is 10 rpm.

Minimum Speed = 2 x Min rpm stp (Holding Register 22 - not changeable by users)



It is suggested to set values equals or higher than the minimum speed default setting. The accelerations and decelerations chosen values are also related to the behavior of the fan at the minimum speed set. Heavy changes could trigger overvoltage alarms.

PFP Out of functioning range alarm

This feature is not available for PFPs.

PFP Flying start (for 3-phase only)

The algorithm can catch the position of the rotor after changing the target speed to 0 and to a new value in short time. If too long time passed and the fan runs at very low speed, it is not possible to catch the speed: the fan brakes and restarts.

PFP Regeneration (for 3-phase only)

The algorithm can catch the position of the rotor after powering OFF and then ON the fan. If too long time passed and the fan runs at very low speed it is not possible to catch the speed and the fan brakes and restarts.

PFP Skip speed Range (for 3-phase only)

This feature allows to skip the resonance frequencies of the fan installation.

To activate this feature the Holding Register 32 must be set at the desired

Avoid Range Start and the Holding Register 33 the desired Avoid Range End.

$$Speed_{SET} \leq \frac{AR_{Start} - AR_{End}}{2} \Rightarrow Speed_{target} = AR_{Start}$$

$$Speed_{SET} > \frac{AR_{Start} - AR_{End}}{2} \Rightarrow Speed_{target} = AR_{End}$$

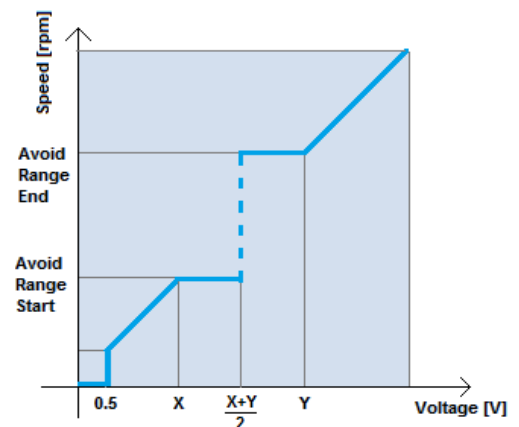

This function should be avoided when used in close control loops application or unstable conditions of the fan could occur.

PFP Soft start

In the following paragraph the starting phase of a fan is shown.

- The first phase when the fan receives a command to start running is the ALIGNMENT. During this phase the driver aligns the rotor.
- The second phase is the dragging phase, where the fan gradually increases its speed to the minimum in open loop. In this phase the current and speed values present in the Input Register can't be taken in consideration.
- The last phase is the closed loop where the sensor less control is active and from the minimum speed to the target speed the fan accelerates with different ramps basing on the fan size and the wheel inertia. The acceleration and deceleration values are different and to avoid overvoltage alarm or loss of synchronism alarm, the deceleration is always lower.

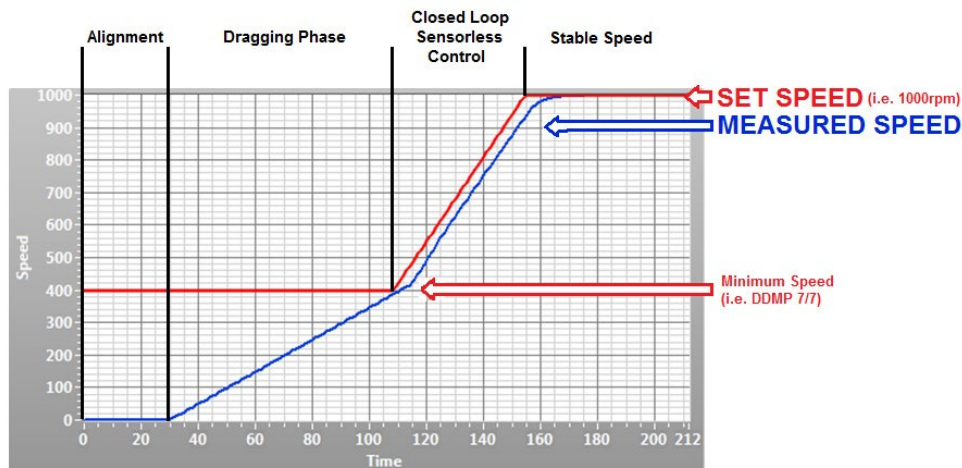

During the ALIGNMENT and DRAGGING phases a Loss of Synchronism alarm could occur if there is a condition of wrong rotor starting position or wrong position estimation during the open loop phase. This is not a blocking alarm; therefore the fan stops and auto-restarts after few seconds.

PFP Starting in Closed-loop torque control (for 5.5 kW drivers only)

Unlike the less powerful drivers, the 5.5 kW drivers start the motor under closed-loop torque control from 0 rpm upwards.

If the rotor of the motor encounters some unexpected resistance to rotation, the driver increases gradually the current until the motor can start correctly.

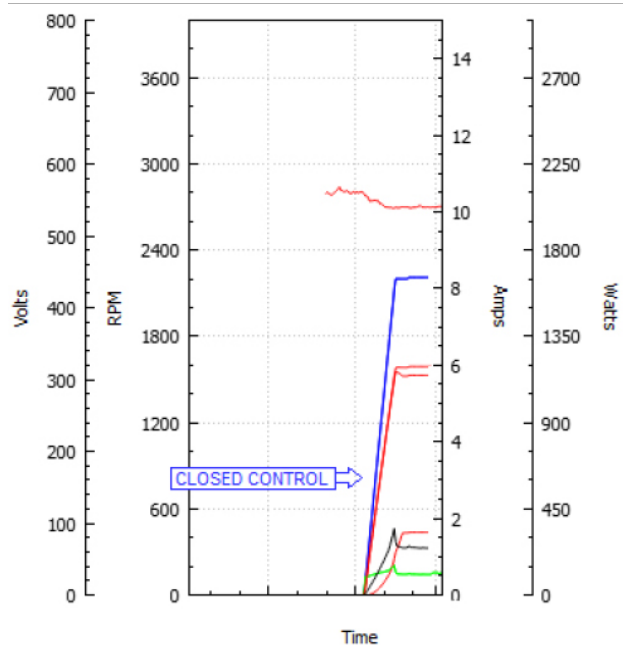

PFP Stop speed (for 5.5 kW drivers only)

When the fan speed is set to 0 rpm and the value of “Stop Speed” is $0 < \text{Stop Speed} < \text{Max Speed}$, then the fan decelerates gradually down to the Stop Speed and then the fan is left coasting to stop.

If the value of “Stop Speed” is $\text{Stop Speed} > \text{Max Speed}$ (default configuration) then the controlled deceleration is de-activated, and whenever the speed is reduced the fan is left coasting down to the required speed or to stand-still.

If the value of “Stop Speed” is “0” and the set speed is also “0”, then the fan impeller is decelerated to standstill and then kept braked.

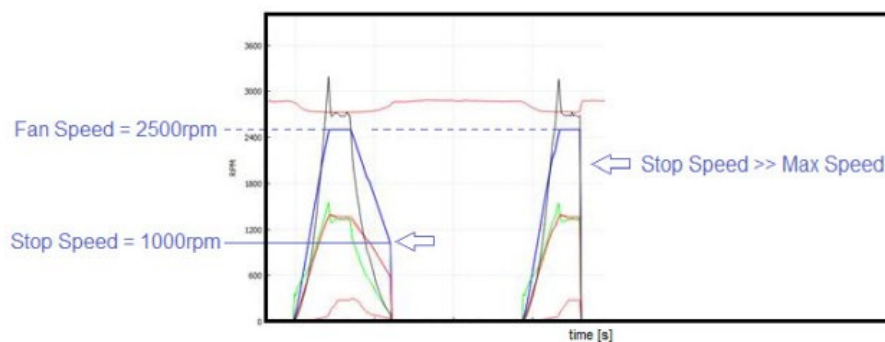

PFP Locked rotor (for 5.5 kW drivers only)

In case of completely locked rotor, the current injected could damage the motor if it lasts for long and if the alarm is repeated indefinitely.

The Loss of Synchronism alarm is repeated for a number of times defined by the "Num Failures Sync" Holding Register 57 (not changeable by users).

Once the max trials are reached, the alarm becomes blocking.

If the fan can restart and can run for one minute before the max number is reached, the counter is reset.

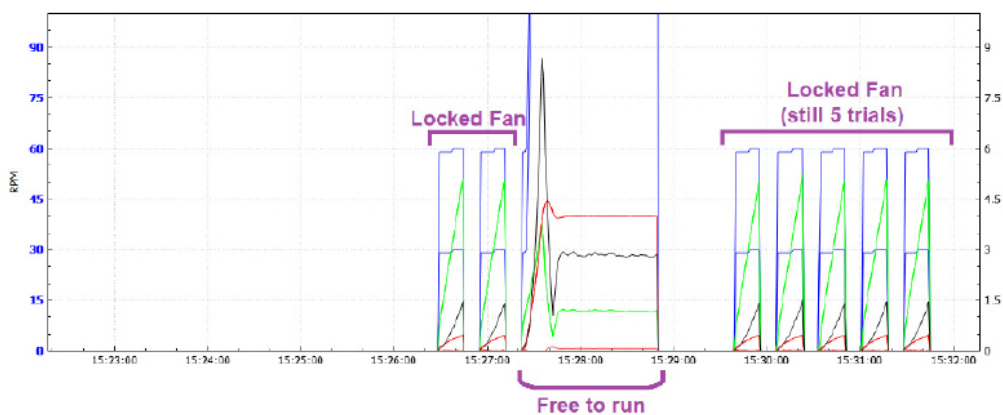

PFP Speed limitation

The speed limits can be adjusted for the signal rescaling, but also to limit the noise in the final application. The Input Register 2 indicates the Speed Reference (minimum speed during alignment and dragging and the Set Speed in Closed Control Loop). The Input Register 3 indicates the Measured Speed.

PFP Power limitation

The driver is set by factory default to the max achievable electrical input power to the driver depending on the model. During the functioning it is possible to monitor the power absorption by reading the Input Register 31. If for some application it is necessary to keep the absorption of the fan below a defined power value, it is possible to reduce the max power out by modifying the Holding Register 36.

PFP Output current limitation

The drivers are set by factory default to the max peak current out that changes depending on the motor windings characteristics.

During the functioning it is possible to read the peak current to the motor by reading the Input Register 12.

It is possible to reduce the motor current by modifying the Holding Register 7. It is suggested to keep the motor current above 3500mA.

PFP Input current limitation (for 1-phase only)

Only the PFP single Phase has an input current limit of 5.9A. At 230V the driver can supply a power output of 1350W. Decreasing the input voltage, a derating occurs both for input and output current:

$$P_{In} = V_{PowerSupply} * I_{InputCurent} \text{ and } P_{Out} = P_{In} * n_{fan}$$

During the functioning it is possible to monitor the input current by reading the Input Register 32.

PFP Bus voltage

The BUS voltage is the DC voltage on the bus capacitors. The driver is continuously monitoring this voltage and will stop the motor in the event of under-voltage or over-voltage.

The value can be monitored through the Input Register 9.

PFP Motor voltage

The motor voltage is the peak value of the phase voltage module. To know the rms line to line value, it must be multiplied by $\sqrt{3}/2$.

The value can be monitored through the Input Register 13.

PFP Enable Function

A safety enable function is available and it is active for the Operating Modes in the following table.

The value can be monitored through the Input Register 28.

Input type	Enable function
0	Not active
1	Active
2	Active
3	Active
4	Active ¹
5	Not active ¹
6	Active ¹

Input type	Enable function
7	Active ²
8	Not active ²
9	Active ²
10	Active
11	Not active
12	Active



WARNING

¹ The operating mode “Constant Airflow” is not available for PFPs. Setting the fan in one of the three Constant Airflow modes could make it turn in an unknown and/or uncontrollable manner.



² During the ALIGNMENT and DRAGGING phases a Loss of Synchronism alarm could occur if there is a condition of wrong rotor starting position or wrong position estimation during the open loop phase. This is not a blocking alarm; therefore the fan stops

PFP Derating And Overheating Protections

Driver overheating: Derating

When the temperature of the driver components overtakes a defined temperature threshold, the performance is automatically reduced to decrease the heating. It is possible to check in real time the temperature by reading the Input Register 15.

If it is not possible to reach a steady thermal equilibrium, the driver shuts down. The protection acts limiting the current to the motor. In this condition the driver goes in alarm.

Once the temperature on the driver decreases under 75°C, the alarm is automatically reset

Motor overheating: Thermal Protector

The motor is protected through one or more Thermal Protectors. If the motor temperature is too high, the thermal protector opens one phase and the driver recognizes the error and stops the fan.



The Motor Winding temperature and the driver derating are dependent on the fan size and on the fan working point. Therefore, it is possible that the fan could work at 50°C without a performance limitation.



WARNING

The Driver and motor areas are rated for operating in a temperature range between -20°C and +40°C. The derating is tested and guaranteed from +40°C to +50°C.

Higher temperatures could damage the motor winding or the performance could be significantly reduced.

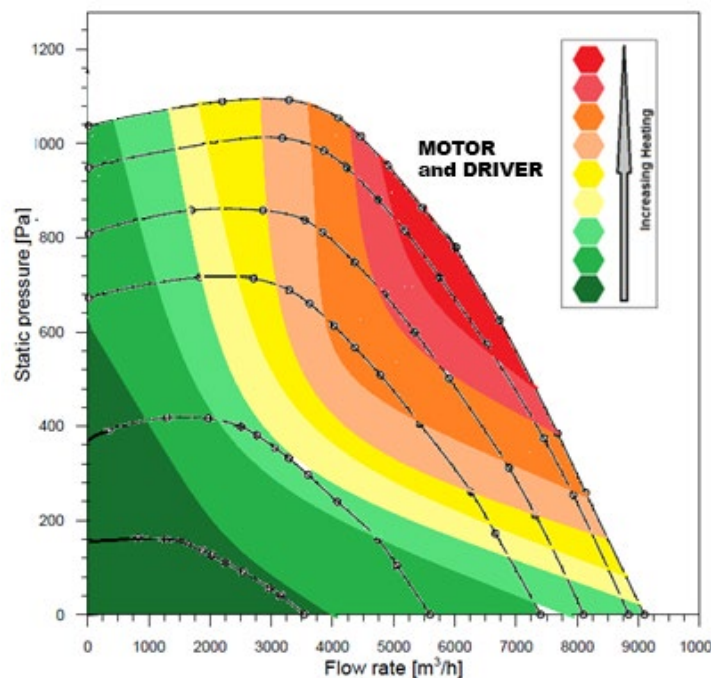

PFP Master & Slave Mode

A Master & Slave connection is necessary when the fans have to operate in parallel and in any Constant-Airflow mode, or under control of the internal PID regulator. Having two or more fans self-controlling independently, while operating in parallel, can make the system unstable. A Master & Slave connection is neither needed nor recommended when the fans in parallel are running in any speed-control mode, even if under control of a common external PID regulator.

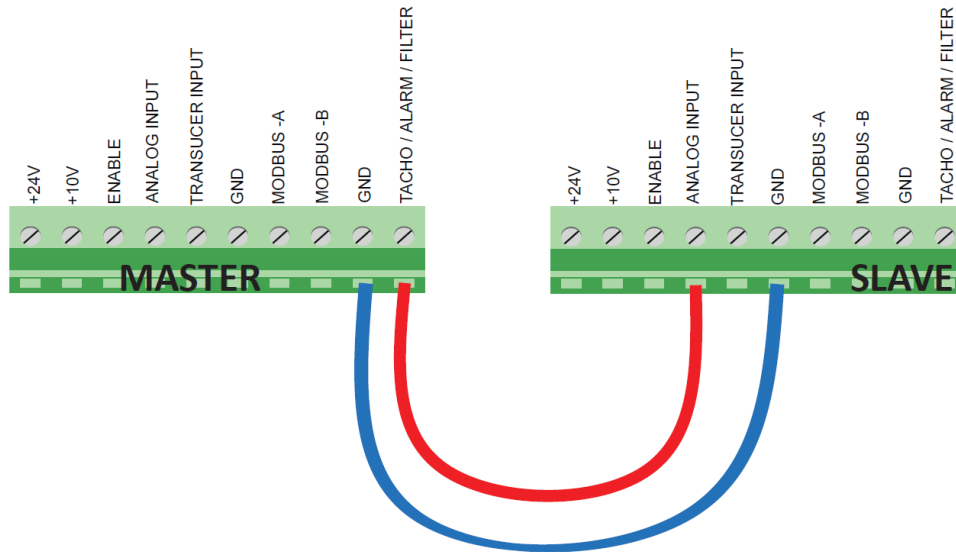

Master and Slave 0-5V PWM out

This feature is not available for PFPs.

Master and Slave 0-10V PWM out

The drivers can be connected in master & slave mode more easily. These drivers have a tachometric output ranging from 0 to 10 V.

The master can have any possible configuration, while the slave must be configured in Analog Speed Control only.

The MASTER must have the Holding Register 46 set at 0 = TACHO.

PFP Variable Switching Frequency (for 3-phase - 4 kW and 5.5 kW)

This feature is used to increase the efficiency and to decrease the heating of the fan. At slow fan speed the driver switching frequency is set at its maximum value 14kHz, while at high speed, the switching frequency is reduced to 8kHz. In this situation the noise generated by the lower switching frequency is covered by the higher fan noise.

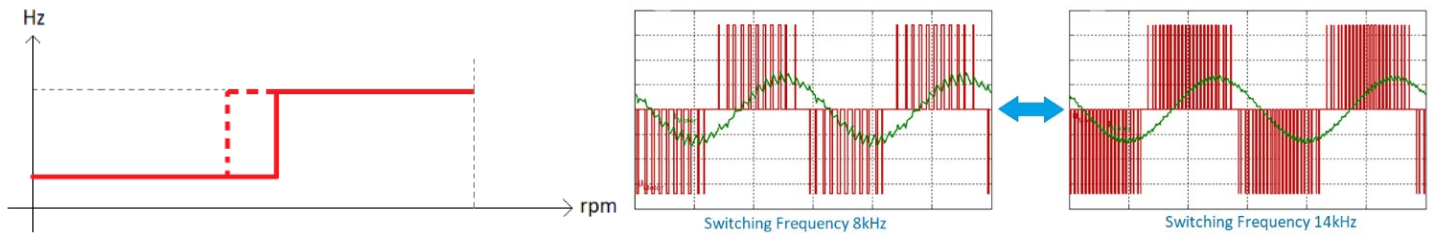

PFP Communication

When trying to enter a value in any holding register, the value is not overwritten if the new value is outside the load boundaries.



The value of the Holding Registers is NOT coerced if trying to set a not allowed value.

Protocol interface:

MODBUS RTU (RS485 or Bluetooth)

Baud rate

The baud rate can be set through the Holding Register 47 and the possible speeds are:

RS-485 CABLE: 9.6kbps and 19.2kbps (higher speeds are not allowed due to the board Opto-Insulators)

UART OFFLINE CABLE: 9.6kbps, 19.2kbps, 38.4kbps and 57.6kbps.

Parity and Stop bits

The parity and the stop bits can be chosen by modifying the Holding Register 48 and the possible choices are:

0	No parity, 2 Stop Bits (default)
1	Odd parity, 1 Stop Bit
2	Even parity, 1 Stop Bit

Supported Functions:

03	Read Holding Registers
04	Read Input Registers
06	Write Single Holding Register



On the Holding Registers the drivers accept Write commands being sent while the motor is running. The register changes are immediately effective on the microcontroller, but the new values are not written in the permanent memory of the driver. If the power supply is switched off, the new values are lost and the driver restarts with the formerly-memorized values. To permanently modify the register settings, any new values in the Holding Registers must be written while the fan is stopped.

PFP Modbus Communication Timeout

With this feature it is possible to stop the fan when the communication is lost, after a period of time set in the Holding Register 56. The register can be set to:

0	No Communication Timeout
1 to 32767	Time expressed in seconds, therefore it is possible to set from 1sec to 9h 6m 8 sec

Modbus Address

The slave device address can be changed from value 1 to 247 by modifying the Holding Register 45. The default address from factory configuration is 1.

Broadcast Address

The Broadcast address is 0.

RS-485 Default Communication Parameters

	1-Phase	3-Phase		
	1.35kW	2.65kW	4kW	5.5 kW
Baud rate	9600	9600	9600	9600
Parity and Stop Bits	0	0	0	0
Modbus Address	1	1	1	1

UART (OFFLINE) Default Communication Parameters

	1-Phase	3-Phase		
	1.35kW	2.65kW	4kW	5.5 kW
Baud rate	57600	57600	57600	57600
Parity and Stop Bits	0	0	0	0
Modbus Address	1	1	1	1



Changing the Baud-rate has an immediate effect, while the other communication parameters require the complete fan power off and consequently power on (wait until the complete discharge of the capacitors and the led turning off, otherwise the changes are not written into the EEPROM).



The Modbus communication parameters (Baud-rate, parity and stop-bits) used for the UART port are fixed on all the PFP drivers. The values in the Holding Registers 47 and 48 apply only to the communication via the RS485 port.

PFP Temporary holding register

The Holding Register 66 is a special register used in each operating mode for setting the speed, the airflow, the slip and the PID reference.

It is not a physical register and it can be written, but it is not possible to read its value. The setting remains active until the fan is powered on.



If the fan is powered off but there is a residual charge, the microcontroller of the driver is still functioning. Therefore, if it is powered on in this situation the value set through the register 66 is still active.

Fixed holding register

The drivers Holding Registers permanently stored into the EEPROM are 64, but only 26 registers are modifiable by the end user.

The most important Holding Register 34 is the Input Type related to the selection of the Operating Mode.

0	Reset	<u>P. 43</u>
1	Min Speed	<u>P. 43</u>
2	Max Speed	<u>P. 44</u>
7	Max Current	<u>P. 44</u>
21	Fixed Speed Setting	<u>P. 44</u>
31	PID positive/negative	<u>P. 44</u>
32	Avoid Range Start	<u>P. 45</u>
33	Avoid Range End	<u>P. 45</u>
34	Input Type	<u>P. 45</u>
35	Stop Speed	<u>P. 45</u>
36	Max Power Out	<u>P. 46</u>

45	Modbus Address	<u>P. 46</u>
46	Tacho\Alarm\Filter	<u>P. 46</u>
47	Modbus Baud rate	<u>P. 46</u>
48	Modbus Parity and Stop Bits	<u>P. 47</u>
50	External PID Setting	<u>P. 47</u>
51	PID Kp	<u>P. 47</u>
52	PID Ki	<u>P. 47</u>
53	PID Kd	<u>P. 47</u>
54	PID Time	<u>P. 47</u>
55	Speed Threshold	<u>P. 48</u>
56	Communication Timeout	<u>P. 48</u>

Holding register description



WARNING

Do not set the values outside the indicated limits, the driver could stop working without any alarm indication, it could be reset or work in an undefined condition.



If the below reported "Allowed values" are written between square brackets, they must be read as "maximum" and "minimum".

Holding Register 0

Holding Register 0: RESET [Adim]

This register can be used to reset the fan by writing the value 1 on it. This register automatically returns to value 0 after being reset. The driver will reset any error condition and it will try to restart.

Allowed values = 0 and 1	Default value = 0
---------------------------------	--------------------------

Holding Register 1

Holding Register 1: Min Speed [RPM]

This register is used to set the minimum speed of the fan.

Allowed values = [Default Value, Max Speed]	Default value = table below
--	------------------------------------

		280-A	315-A	355-A	400-A	450-A	450-B/-C	500-A	500-B/-C	560-A	500-B/-C	630-A	710-A
1.35kW	1-Phase	500	400	400	300	300	-	300	-	-	-	-	-
2.65kW	3-Phase	300	300	150	150	150	-	-	-	-	-	-	-
4kW	3-Phase	-	-	-	-	300	-	300	-	300	-	300	-
5.5kW	3-Phase	-	-	-	-	-	250	-	250	-	250	300	300

Holding Register 2

Holding Register 2: Max Speed [RPM]

This register is used to set the max speed of the fan.

Allowed values = [Min Speed, Default Value]	Default value = table below
--	------------------------------------

		280-A	315-A	355-A	400-A	450-A	450-B	450-C	500-A	500-B	500-C	560-A	560-B	560-C	630-A	710-A
1.35kW	1-Phase	3350	2890	2500	2000	168	-	-	1425	-	-	-	-	-	-	-
2.65kW	3-Phase	3350	2890	2500	2480	1950	-	-	-	-	-	-	-	-	-	-
4kW	3-Phase	-	-	-	-	2030	-	-	1900	-	-	1620	-	-	1460	-
5.5kW	3-Phase	-	-	-	-	-	2770	2350	-	2500	2100	-	2060	1850	1460	1200

Holding Register 7

Holding Register 7: Max Current [mA]

This register is used to reduce the max motor current.

Allowed values = [1, Default Value] | **Default value** = table below



Although the value of the Max Current can be set at any value being lower than the original default one, it is not recommended using a value that is 0.3 times below the default one.

		280-A	315-A	355-A	400-A	450-A	450-B	450-C	500-A	500-B	500-C	560-A	560-B	560-C	630-A	710-A
1.35kW	1-Phase	6000	6500	6500	6500	6500	-	-	6500	-	-	-	-	-	-	-
2.65kW	3-Phase	4200	5700	6700	8000	6700	-	-	-	-	-	-	-	-	-	-
4kW	3-Phase	-	-	-	-	12000	-	-	12000	-	-	12000	-	-	12600	-
5.5kW	3-Phase	-	-	-	-	-	13500	11000	-	13500	11000	-	11700	11700	12600	11000

Holding Register 16

Holding Register 16: Speed Threshold Low [RPM]

This register can be used to set the speed threshold low.

The register is active when the register 46 is set to the value 3.

Holding Register 21

Holding Register 21: Fixed Speed setting [RPM]

This register can be used to set the speed in **Fixed Speed Control Mode**.

The register is active when the Input Type **Holding Register 34** is set to the value 2.

Allowed values = [Min Speed , Max Speed] | **Default value** = 0

Holding Register 31

Holding Register 31: PID Positive/Negative [Adim]

This register can be used to invert the feedback behavior of the PID.

Allowed values = 0 and 1 | **Default value** = 0

Holding Register 32

Holding Register 32: Avoid Range Start [RPM]

This register combined with the Avoid Range End can be used to skip some resonance frequencies of the fan.

Allowed values = [0, Avoid Range End] | **Default value** = 20000

Holding Register 33

Holding Register 33: Avoid Range End [RPM]

This register combined with the Avoid Range Start can be used to skip some resonance frequencies of the fan.

Allowed values = [Avoid Range Start, 20000]	Default value = 20000
--	------------------------------

Holding Register 34

Holding Register 34: Input Type [Adim]

This register defines all the possible operating modes:

0	Modbus Speed Control	The speed is set by modifying the register 66
1	Analog Speed Control	The speed is set through the analog signal
2	Modbus Fixed Speed Control	The speed is set by modifying the register 21
3	Master & Slave	The fan is configured as slave and follows the master
4	Analog Constant Airflow	The constant airflow is set through the analog signal ¹
5	Modbus Temporary Constant Airflow	The constant airflow is set by modifying the register 66 ¹
6	Modbus Fixed Constant Airflow	The constant airflow is set by modifying the reg. 39 ¹
7	Analog Asynchronous Emulation	The emulation is set through the analog signal ²
8	Modbus Temporary Asynchronous Emulation	The emulation is set by modifying the register 66 ²
9	Modbus Fixed Asynchronous Emulation	The emulation is set by modifying the register 30 ²
10	Analog Ref. PID Closed Control Loop	The PID ref. is set through the analog signal
11	Modbus Temporary Ref. PID Closed Control Loop	The PID ref. is set by modifying the register 66
12	Modbus Fixed Ref. PID Closed Control Loop	The PID ref. is set by modifying the register 50



¹ The operating mode “Constant Airflow” is not available for PFPs. Setting the fan in one of the three Constant Airflow modes could make it turn in an unknown and/or uncontrollable manner.



WARNING

² The algorithm related to the operating mode "Asynchronous Emulation" does not produce significant differences on PFPs in comparison to the operating mode "Speed control". Therefore, its use is not recommended.

Holding Register 35

Holding Register 35: Stop Speed

This register can be used to set the stop speed.

When the fan speed is set to 0 rpm if the $0 < \text{Stop Speed} < \text{Max Speed}$, the fan decelerates gradually until the Stop Speed value is reached and then the fan is let in free run.

Allowed values = [0, 20000]	Default value = 20000
------------------------------------	------------------------------

Holding Register 36

Holding Register 36: Maximum Power [W]

This register can be set to reduce the power out to the motor.

Allowed values = [10, Default Value] | **Default value** = table below

		Value
1.35kW	1-Phase	1350
2.65kW	3-Phase	2650
4kW	3-Phase	4100
5.5kW	3-Phase	4200-5600*

*The value depends on the type of impeller installed (450-B: 5600; 450-C: 4200; 500-B: 5600; 500-C: 4800; 560-B: 5300; 560-C: 5600; 630-A: 5200; 710-A: 4200).

Holding Register 45

Holding Register 45: Modbus Address [Adim]

This register can be set to change the Modbus address of a driver.

Allowed values = [1,247] | **Default value** = 1

Holding Register 46

Holding Register 46: Tachometric / Alarm / Threshold [Adim]

This register can be set to set the digital output function.

Allowed values = table below | **Default value** = 0

The possible settings are:

0	Tachometric	The digital output indicates the measured speed through a PWM signal
1	Alarm	The digital output indicates when an alarm occurs
2	Threshold	The digital output indicates when the speed set in the Holding Register 55 is overtaken
3	Out of Functioning Range	The digital output indicates when the fan is working in a defined range of speeds

Holding Register 47

Holding Register 47: Modbus Speed [10¹ kbps]

This register can be set to set the Modbus speed.

Allowed values = table below | **Default value** = 96

96	corresponding to 9.6kbps
192	corresponding to 19.2kbps

Holding Register 48

Holding Register 48: Modbus Stop Bits [Adim] (Default = 0)

This register can be used to set the parity and the stop bits.

Allowed values = table below | **Default value** = 0

0	2 Stop Bits/No Parity
1	1 Stop Bit/Even Parity
2	1 Stop Bit/Odd Parity

Holding Register 50

Holding Register 50: External Set [10–1 V]

This register can be used to set the reference of the PID control.

Allowed values = [0, 100] | **Default value** = 0

The register is active when the Input Type Holding Register is set to the value 12.

Holding Register 51

Holding Register 51: Kp [Adim]

This register can be used to set the Proportional Gain of the PID control.

Allowed values = [0, 32767] | **Default value** = 0

Holding Register 52

Holding Register 52: Ki [Adim]

This register can be used to set the Integral Gain of the PID control.

Allowed values = [0, 32767] | **Default value** = 0

Holding Register 53

Holding Register 53: Kd [Adim]

This register can be used to set the Derivative Gain of the PID control.

Allowed values = [0, 32767]	Default value = 0
------------------------------------	--------------------------

Holding Register 54

Holding Register 54: Period [ms]

This register can be used to set the time constant of the PID control.

Allowed values = [0, 32767]	Default value = 0
------------------------------------	--------------------------

Holding Register 55

Holding Register 55: Speed Threshold (or Speed Threshold HIGH) [RPM]

This register can be used to set the speed threshold, when the measured speed in the Input Register 3 overtakes the threshold value.

Allowed values = [0, Max Speed]	Default value = 0
Allowed values (Functioning Indication mode) = [Speed Threshold Low, Max Speed]	

Speed Threshold =0 means that it is **DEACTIVATED**

Holding Register 56

Holding Register 56: Communication Timeout [s]

This register can be used to set a timeout period for the communication.

Allowed values = [0, 9hour 8min 8sec]	Default value = 0
--	--------------------------

At the end of the period set into the register the fan stops and there is an Alarm indication. To restart a reset command must be sent.

Communication Timeout = 0 means that it is **DEACTIVATED**

Input register description

The Modbus Input Registers are in total 33, but only 14 are useful for the end user.

2	Speed Reference	[rpm]	15	Module Temperature	[10-1 °C]
3	Measured Speed	[rpm]	17	Alarm 2	[Adim]
9	Bus Voltage	[10-1V]	28	Enable Input	[10/216 V]
10	Alarm 1	[Adim]	29	Analog Input	[10/216 V]
12	Motor Current	[mA]	30	Transducer Input	[10/216 V]
13	Motor Voltage	[10-1V]	31	Measured Power	[W]
14	Analog Input	[10-1V]	32	Input Current	[mA]

Input Register 2: Speed Reference [rpm]

This register indicates the speed reference during the functioning. During the starting phase, it is equal to the Min Speed and then gradually increases to the target speed depending on the selected mode.

Input Register 3: Measured Speed [rpm]

This register indicates the speed during the functioning.

Input Register 9: Bus Voltage [10–1 V]

This register indicates the rectified voltage after the PFC stage.

Input Register 10: Alarm 1 [Adim]

This register must be combined with the Alarm2 register (see the table in paragraph 18.2)

Input Register 12: Motor Current [mA]

This register indicates the peak value of the line current module.
To know the rms value, it must be divided by $\sqrt{2}$.

Input Register 13: Motor Voltage [10–1 V]

This register indicates the peak value of the phase voltage module.
To know the rms line to line value, it has to be multiplied by $\sqrt{3/2}$.

Input Register 14: Analog Voltage [10–1 V]

This register indicates the analog voltage value present at the input.

Input Register 15: Module Temperature [10–1 °C]

This register indicates the temperature of the power module of the driver. When the value exceeds the temperature threshold, the driver enters in a derating process where the performances are automatically decreased until a thermal equilibrium below the temperature threshold is reached. If this equilibrium is not reached, the fan stops and an alarm condition is activated. As soon as the heating decreases and the power module temperature is below the temperature threshold, the alarm is automatically reset.

This threshold value can be read in Holding Register 29.

Input Register 17: Alarm 2 [Adim]

This register must be combined with the Alarm1 register.

Input Register 28: Enable Input [Adim]

This input indicates the ENABLE state.

The value must be multiplied by 10V/216 to have the corresponding voltage value.

Input Register 29: Analog Input [Adim]

This input indicates the Reference Value.

The value must be multiplied by 10V/216 to have the corresponding voltage value.

Input Register 30: Transducer Input [Adim]

This input indicates the Transducer Value.

The value must be multiplied by 10V/216 to have the corresponding voltage value.

Input Register 31: Measured Power [W]

This register indicates the absorbed power.

Input Register 32: Input Current [mA]

This input indicates the input absorbed current.

Fan info and Modbus registers

The Holding Register 44 indicates the fan model.

		280-A	315-A	355-A	400-A	450-A	450-B	450-C	500-A	500-B	500-C	560-A	560-B	560-C	630-A	710-A
1.35kW	1-Phase	1	2	3	4	5	-	-	6	-	-	-	-	-	-	-
2.65kW	3-Phase	1	2	3	4	5	-	-	-	-	-	-	-	-	-	-
4kW	3-Phase	-	-	-	-	1	-	-	2	-	-	3	-	-	4	-
5.5kW	3-Phase	-	-	-	-	-	1	6	-	2	7	-	3	8	4	5

The Input Register 0 indicates the driver firmware version and the Input Register 1 indicates the driver model.

	1-Phase	3-Phase		
	1.35kW	2.65kW	4kW	5.5 kW
Frequency Converter Model	49696	40995	49187	61475
Frequency Converter Code	1431F2	1431F3	1431F9	1431G5

PFP Alarm Handling

When a malfunctioning occurs, the driver has two possible behaviors depending on the cause of the alarm:

BLOCKING	The cause of the alarm is very dangerous -> The driver stops immediately. To restart the fan, once the problem has been corrected, it is necessary to reset the fan or power the driver off for 5 minutes.
AUTO-RESTARTING	The cause of the alarm is contingent to a wrong setting or wrong working condition. The alarm indications are activated, but after some seconds the fan tries to restart automatically.

Monitoring

The alarms can be monitored through three different ways:

- Modbus Registers
- Blinking LED
- Digital Output

Modbus registers - Alarm description

In the following table, the alarms and the values stored in the related Modbus Input Register 10 and Input Register 17 are indicated

Alarm 1	Alarm 2	Description	Actions	Type
0	0	Default operation – No Errors	No Actions	ALARM 1
1	0	Memory error	Blocking condition	ALARM 2
2	0	Short Circuit	Blocking condition	ALARM 3
3	0	Loss of synchronism	Auto-restarting condition*	ALARM 4
4	1	Input Voltage outside range (only with motor stopped)	Auto-restarting condition	ALARM 4
4	32	BUS overvoltage (instantaneous measurement)	Auto-restarting condition	ALARM 4
4	33	BUS undervoltage (instantaneous measurement)	Auto-restarting condition	ALARM 4
4	34	Input relay not closed	Auto-restarting condition	ALARM 4
4	49	Missing phase – U cable disconnected	Blocking condition	ALARM 4
4	50	Missing phase – V cable disconnected	Blocking condition	ALARM 4
4	51	Missing phase – W cable disconnected	Blocking condition	ALARM 4
4	52	High starting current	Auto-restarting condition	ALARM 4
4	113	Overtemperature	Auto-restarting condition	ALARM 4
4	255	Loss of communication	Blocking condition	ALARM 4

*After loss of synchronism, the auto-restarting condition is activated for 1.35 kW, 2.6 kW and 4 kW drivers. In case of loss of synchronism for 5.5 kW drivers, the blocking condition is activated after five failed attempts and the fan must be reset manually.



Check the blocking reasons and close the gate in case of opposite flow.



WARNING

The Driver is NOT protected against a very high-power supply voltage.
A very low power supply voltage during the motor running could damage Driver.

Blinking LED - Alarm description

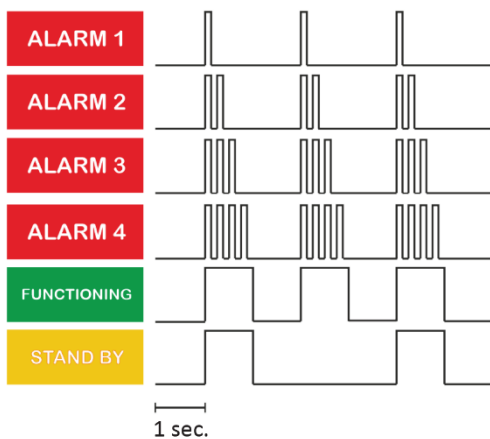

The system status can be displayed through the LED on the driver plate (see par. 9.6).

In the following figure on the right the blinking LED is shown.

Digital Alarm Output

The driver output can be configured as Alarm output by modifying the Holding Register 46 to value 1. During the normal functioning, the value is 0V and, when an alarm occurs, the output value is 10V.

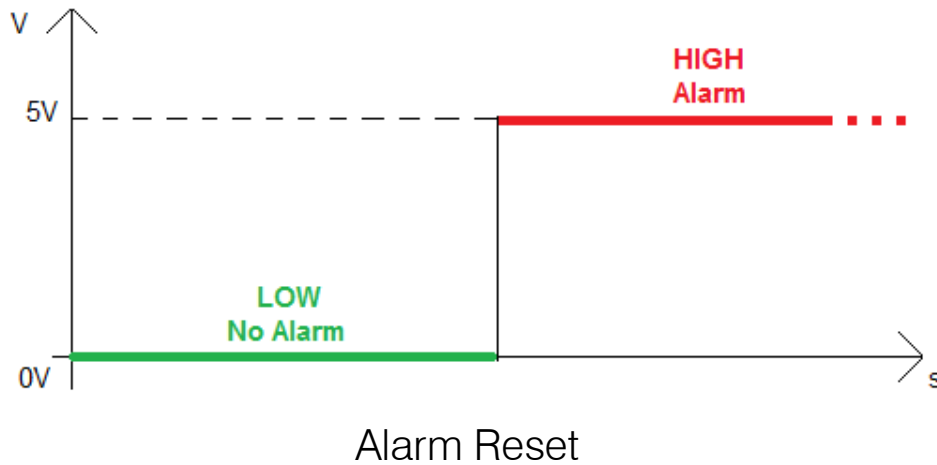

The alarms are automatically reset following the action of the table below:

Operating Mode	Input Type	Action
Analog	1, 4, 7, 10	Signal set to 0V
Fixed	2, 6, 9, 12	Registers 21, 39, 30 and 50 set to 0

As concerns the Temporary Modbus mode, it is necessary to reset the fan by setting the Holding Register 0 to value=1 instead of setting to 0 the Register 66.

Temporary	0, 5, 8, 11	Register 0 set to 1
-----------	-------------	---------------------

PFP Driver Replacement

These fans, their motors and drivers are designed for maintenance-free long-lasting operation and for high reliability. Under normal operating conditions, there are no parts inside which may need servicing.

If, under extreme conditions, a driver should need replacement, the Printed Circuit Boards of the driver shall never be removed from inside the driver enclosure. Removing them from their enclosure would compromise their thermal bonding onto the heat-sink and might easily damage some critical components.

The entire cylindrical enclosure is designed, instead, to be removed from the motor and replaced. The replacement of the driver does not affect the rotor and impeller assembly, and consequently does not require re-balancing of the fan.

Trend - VSD2H Variable Isolator Speed Drives

VSD2H Variable Isolator Speed Description

Variable motor speed drives suitable for HVAC applications where the speed control of motors can be applied. They convert fixed frequency and voltage from the mains supply to variable frequency and voltage enabling motors to be used with maximum efficiency resulting in significant energy savings.

The control keypad can be mounted on the front of the unit or can be remotely connected by way of a 2 m cable and mounted on a panel or used as a handheld unit.

The keypad accesses the startup wizard which facilitates the application configuration for the user (pump/fan, PID loops, multi-pump, cascade control).

VSD2H Variable Isolator Speed Features

- 380 to .480 Vac 3 phase
- Current rating range from 3 A to 310 A.
- IP21 and IP5.4 models available
- Optional Trend system network interfaces (NXNI or NXIP)
- Application configurable using wizard for a number pump or fan scenarios.
- Real time clock fitted with battery
- Integrated RFI filter for typical building installation
- Versatile PC tools available
- Slim, space-saving, "bookshell" design
- Varnished printed circuit boards to maximise reliability.

Physical (dimensions in mm)

Physical (dimensions in mm)

3 A to 105 A units (unit size MR4 to MR7) - wall mounting

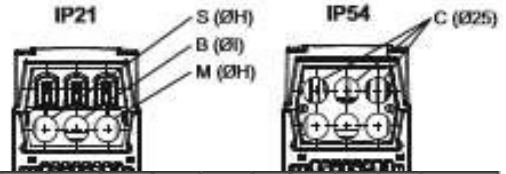
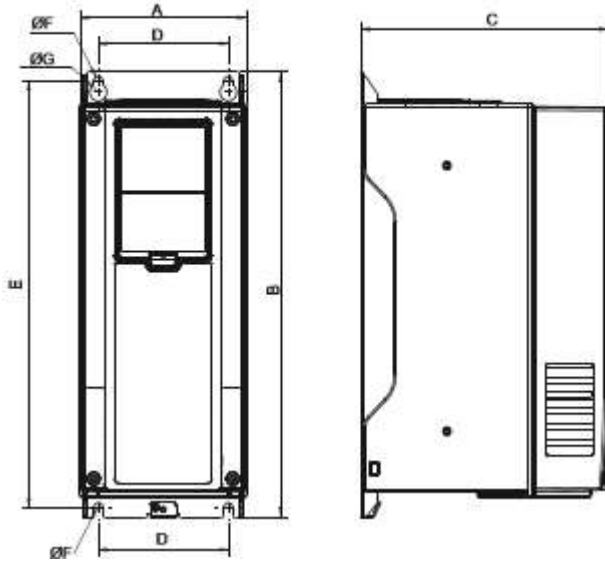

Current (A)	A	B	C	D	E	ØF	ØG	ØH	ØI	Frame
3 to 12	128	328	190	100	313	7	13	25	25	MR4
18 to 31	144	419	214	115	406	7	14	33	25	MR5
38 to 61	195	557	229	148	541	9	15.5	40	33	MR6
72 to 105	237	660	259	190	645	9	16	50	50	MR7
140 to 205	290	966	343	217	947	9	16	60	60	MR8*
261 to 310	480	1150	365	400	1122	9	16	59	59	MR9*

cal (continued)

(dimensions in mm)

140 A to 205 A units
(unit size MR8)
wall mounting

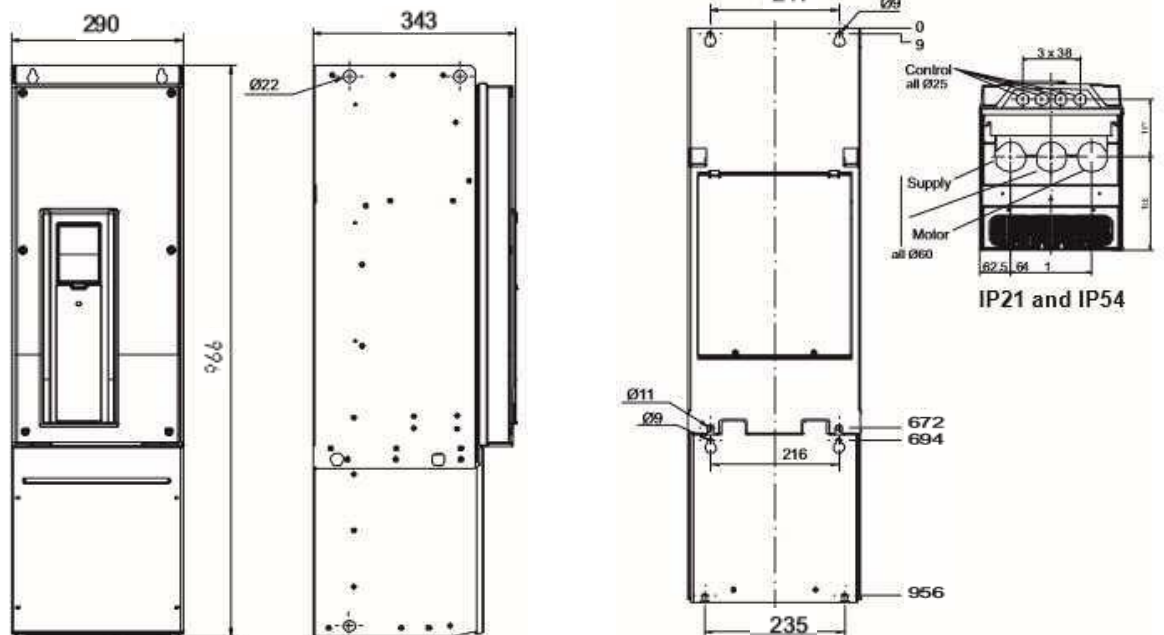

261 A and 310 A units (unit size MR9) wall mounting

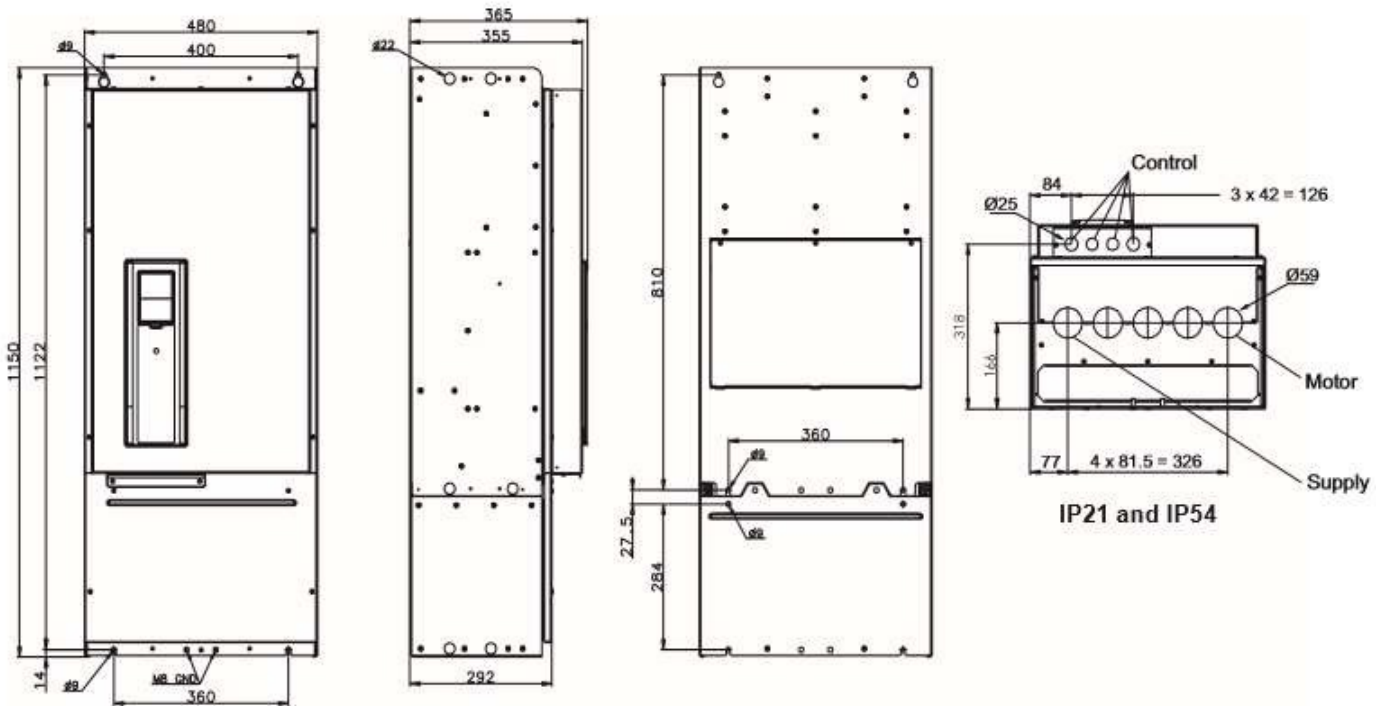

Functionality

The VSD2H range of variable speed drives provides 20 models (3 A to 310 A) for voltages from 380 to 480 Vac 3 phase with either IP21 or IP5.4 rating. Designed for use in the HVAC environment they enable fans and motors to regulate delivery of air and water in variable flow applications. Where flow rates may be reduced, motor energy can be significantly cut as the relationship between flow rate and power follows a cube law hence reducing flow by 20% reduces power by 50%. The drives also enable saving in installation costs: switchgear is eliminated, motor cables are reduced from 6 to 3 wires for larger drives, power factor correction capacitors are not required, size and cost of cabling and fuses is minimised (as starting current is kept within nominal value).

The built-in application can be configured to suit the user's application using the start-up wizard; select either pump or fan, and enter nominal motor information. There are additional mini-wizards for setting up multi-pump control and the PID controller, and performing a resonance sweep.

Hardware

- **Unit:** The unit is housed in a slim, space saving, bookshelf style enclosure that should be mounted vertically on a wall or on the back panel of a cubicle. Enough space should be left round the unit for cooling. Most units have .4 point mounting with two keyhole slots.
- **System:** The drive consists of the main unit, the cover, and a detachable keypad unit.

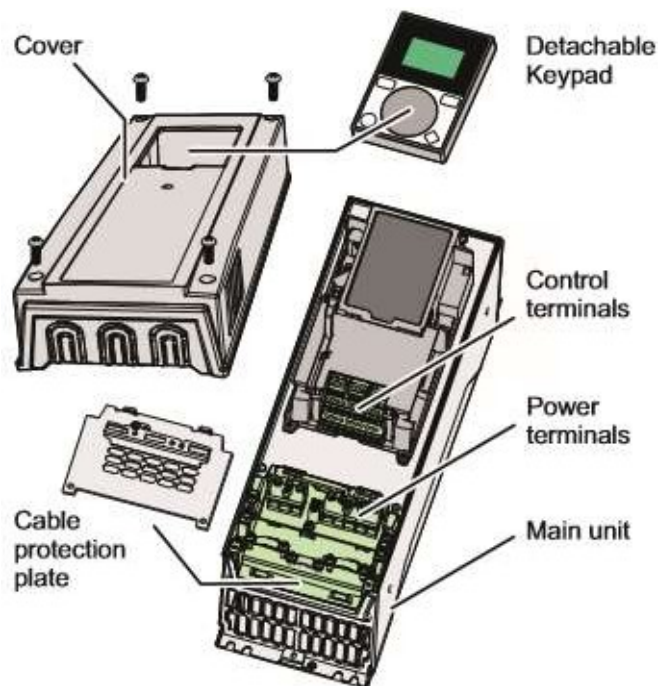

Main unit: The main unit consists of the power unit and the control unit.

The unit will be housed in a slim, space saving, bookshelf style enclosure that should be mounted vertically on a wall or on the back of a cubicle. Enough space should be left around the unit for cooling. Most units have .4 point mounting with two keyhole slots.

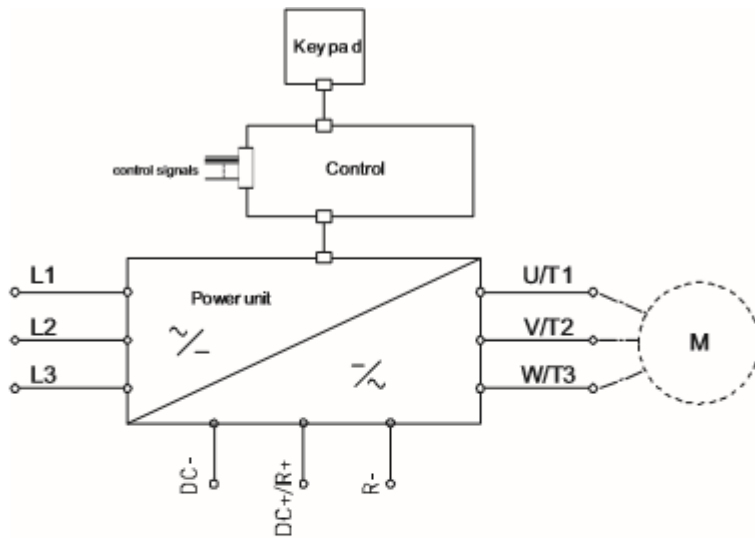

The power unit provides connections for the input mains supply (L1, L2, L3) and the output supply to the motor (U, V, W).

The control unit is based around a microprocessor. The microprocessor controls the motor based on the information it receives through measurements, parameter settings, control I/O and from the control keypad. The control unit of the frequency converter consists of the control board and up to 4 additional boards connected to the slot connectors (identified by letters A, B, D, E) of the control board.

The power unit provides connections for the input mains supply (L1, L2, L3) and the output supply to the motor (U,V,W).

The control unit is based around a microprocessor. The microprocessor controls the motor based on the information it receives through measurements, parameter settings, control I/O and from the keypad. The control unit of the frequency converter consists of the control board and up to .4 additional boards connected to the slot connectors (identified by letters A, B, D, E) of the control boar

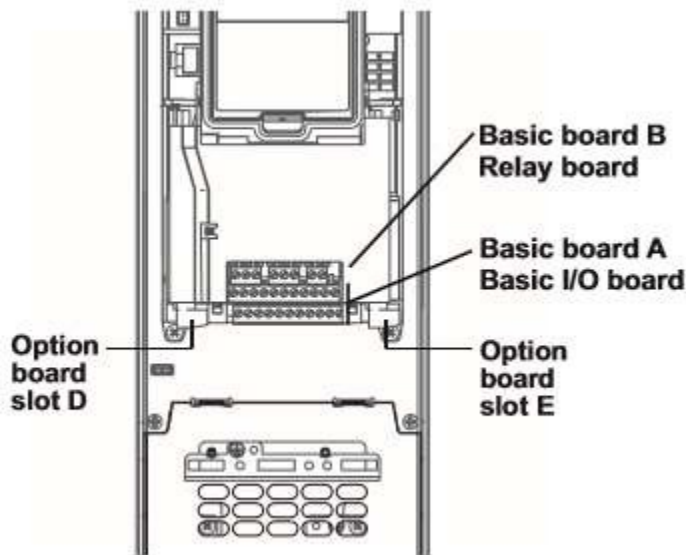

When the frequency converter is delivered from the factory, the control unit includes the standard complement of two basic boards, the basic I/O board in slot A, and the Relay Board in slot B.

Additional boards can be added to slots D and E. An NXIP or NXNI Trend network interface can only be fitted in slot D.

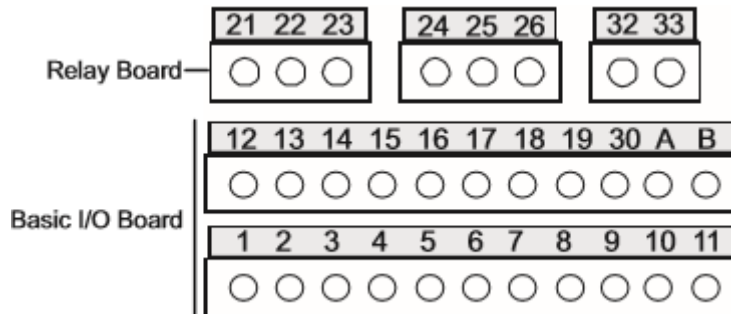

The basic boards terminals are shown above. The basic I/O Board (fitted as standard) has:

2 analogue input channels, separately switchable to voltage (0(2) to 10V) or current (0(.4) to 20 mA) 6 digital input channels (0 to 5 V =0, 15 to 30 V =1)

1 analogue output channel, switchable to voltage (0 to 10V) or current (.4 to 20 mA). RS.485 serial bus terminal pair (for BACnet MS/TP or Modbus)

The defaults for the analogue inputs and output are indicated in the diagram below; they may be changed using the DIP switches (see below).

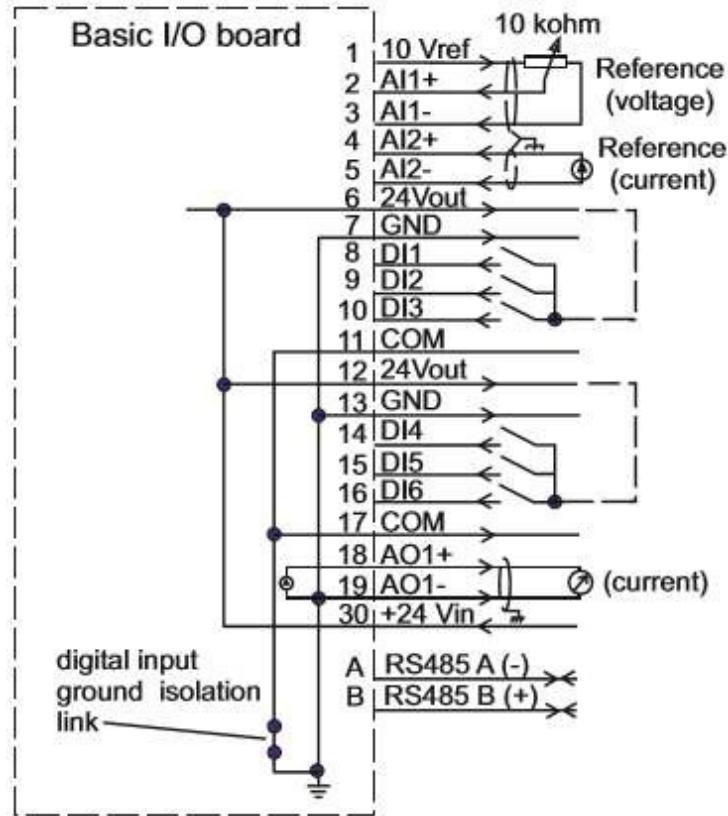

Terminal	Signal	Information	Factory Setting
1	10 Vref	+10 Vdc Reference voltage	10 mA max.
2	AI1+	Analogue input 1 voltage or current	DIP switch 4 selects V or mA. Differential input if not connected to ground
3	AI1-	Analogue input 1 common	
4	AI2+	Analogue input voltage or current	DIP switch 3 selects V or mA. Differential input if not connected to ground
5	AI2-	Analogue input c2 ommon	
6	24 Vout	24 V auxiliary voltage output	±10 %, 250 mA max.
7	GND	I/O ground	Ground for reference and controls
8	DI1	Digital input 1	Rin= 5 kohm min. 0 to 5 V = '0' 15 to 30 V = '1'
9	DI2	Digital input 2	
10	DI3	Digital input 3	
11	COM	Digital input common	Common for DI1 to 6. Can be disconnected from ground by removing link
12	24 Vout	24 V auxiliary voltage output	as terminal 6
13	GND	I/O ground	as terminal 7
14	DI4	Digital input 4	Rin= 5 kohm min. 0 to 5 V = '0' 15 to 30 V = '1'
15	DI5	Digital input 5	
16	DI6	Digital input 6	
17	COM	Digital input common	as terminal 11
18	AO1+	Analogue signal (+output)	DIP switch 2 selects V (0 to 10V) or I (0 to 20 mA)
19	AO1-	Analogue output common	
30	+24 Vin	24 Vdc auxiliary input	+24 Vdc, 100 mA , ±10% for backup power*
A	RS485 A (+)	Fieldbus communication	Differential receiver/transmitter; Use for BACnet MS/TP, or MODBUS RTU
B	RS485 A (-)		

“The control board can be powered externally by connecting an external power source to terminal 30. This voltage is sufficient for parameter setting and for keeping the control unit active. Note however that the measurements of the main circuit (e.g. DC-link voltage, Unit temperature) are not available when the mains is not connected.”

The Basic Relay Board (fitted as standard) has:

- 2 changeover relay output channel
- 1 thermistor input channel

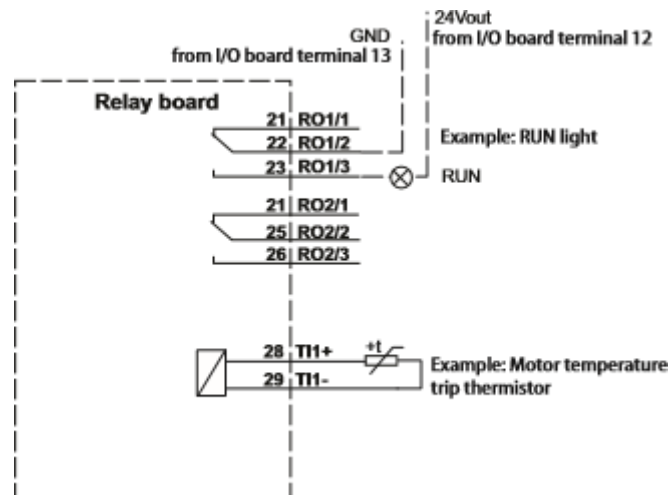

Terminal	Signal	Information	Factory Setting
21	RO1/1	Relay output 1 Normally Closed	RUN (active)
22	RO1/2	Relay output 1 Common	
23	RO1/3	Relay output 1 Normally Open	
24	RO2/1	Relay output 2 Normally Closed	FAULT (active)
25	RO2/2	Relay output 2 Common	
26	RO2/3	Relay output 2 Normally Open	
28	TI1+	Thermistor input	Motor temperature trip thermistor (PTC). If thermistor circuit is not used it must be short-circuited
29	TI1-		

An optional system network interface can be fitted into the VSD2H drive. It is plugged into slot D, and enables the unit to be monitored and controlled from supervisors, and from the controllers. There are the IQ system current loop Lan interface. NXNI (which provides a standard four wire current loop Lan terminal set), and the Ethernet interface, nxip. See NXNI data sheet TA200826 for details. Note that the NXNI allows the unit to be monitored by all controllers, but it can only be written to by IQ3, IQ4 or IQeco controllers.

DIP Switch

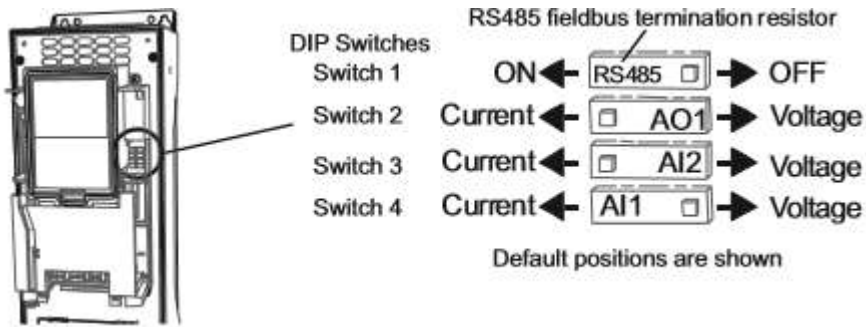

The 4 DIP switches have 3 functional positions, left, middle and right. The middle position is used for test mode. The switches are used to set the following parameters:

- Switch 1: RS485 fieldbus Terminator resistor, on or off (default off)
- Switch 2: Analogue Output 1, current or voltage (default current)
- Switch 3: Analogue Input 2, current or voltage (default current)
- Switch 4: Analogue Input 1, current or voltage (default voltage)

Quick setup

A group of the parameters most commonly used during installation and commissioning.

Monitoring

This enables parameters to be monitored only.

Parameters

This enables the parameters to be edited. First the group of parameters is selected, then the individual parameter. The actual meanings of the parameters vary with the configuration being used.

Diagnostics

This enables current and historical faults to be viewed, faults to be reset, and counters and software information to be viewed.

I/O and hardware

This selects basic I/O, any additional boards in slots D or E (an NXNI or NXIP in slot D would be shown as OPTCO), Real time clock, the drive fan, keypad settings and fieldbus (RS485 or Ethernet) parameters.

User settings

Language, application, parameter backup and restore to and from keypad.

Favourites

(advanced commissioning keypad only) This enables the user to collect a set of parameters from any of the keypad menus.

Digital Input Isolation

The digital inputs (DI1 to DI6) can be isolated from ground by removing a link on the control board as shown.

Ethernet Connection

The Ethernet connection for BACnet over IP or MODBUS TCP is situated under the cover to the left of the control keypad, and the cable is run in a channel cut in the plastic flap. A shielded RJ45 connector should be used.

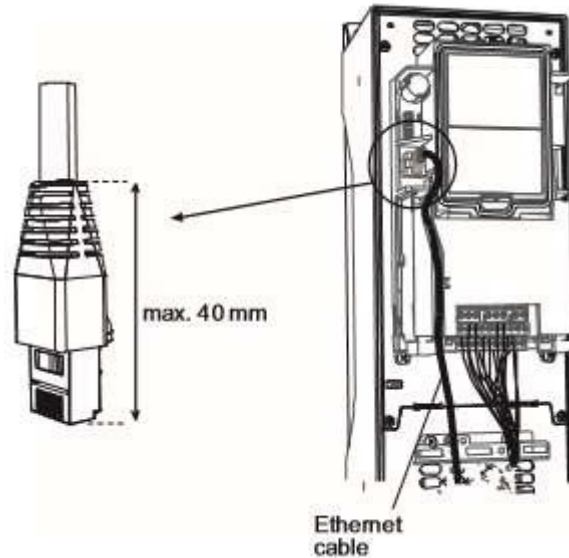

RS485 Connection

The RS485 connection for BACnet over MS/TP or MODBUS RTU uses terminals A and B (A negative, B positive) in the basic I/O board terminal set. STP (Shielded twisted pair), type Belden cable 9841 or similar should be used. The terminator (see above DIP Sw 1) should only be switched on if the unit is at the end of the bus.

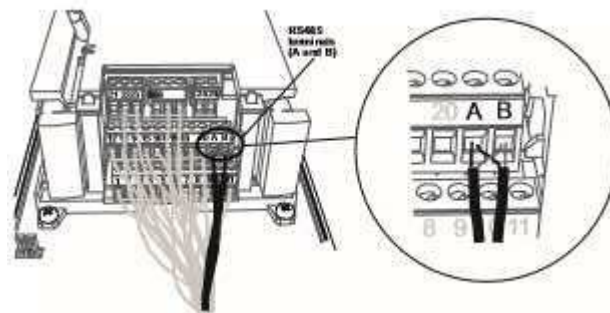

Real Time Clock

The VSD2H has a real time clock with timer functions. The unit comes complete with timer functions. The unit comes complete with a Real Time Clock battery installed to maintain the time during power failure.

Integrated RFI-filter

The units have integrate RFI filters, enabling them to comply with EN61800-3 category C2 (suitable for public electricity networks such as buildings).

Integrated DC Choke

The units are equipped with DC chokes to reduce harmonics (THD), enabling them to comply with EN61000-3-12,

Integrated Stress Removal

Stress removal and 360° grounding of power cables inside the unit with clamps. No need for extra glands.

External Keypad

The External Keypad can be used for setting the frequency converter's parameters, reading status data, and giving control commands. It is detachable and can be operated externally being connected via a cable to the main unit. There are two accessory kits available.

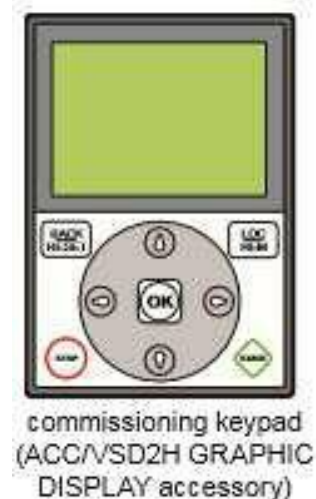
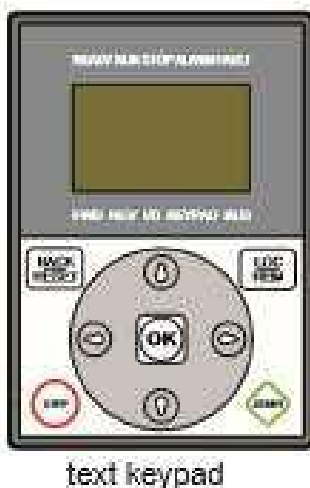

ACC/VSD2H/Hand Held Kit

This enables the keypad to be detached from the unit and to be used as a hand held unit connected to the VSD by a 2 m cable.

ACC/VSD2H/Door Mounting Kit

This enables the keypad to be detached from the unit and to be mounted in the panel door connected to the VSD by a 2m cable.

The standard text keypad features an alphanumeric display with seven indicators for run status (READY, RUN, STOP, ALARM, FAULT, FWD, REV), and three indicators for control source (I/O, KEYPAD, BUS). There are also two text lines displaying description (of menu, value or fault) and location (reference to menu and parameter) or value (numerical, textual values).

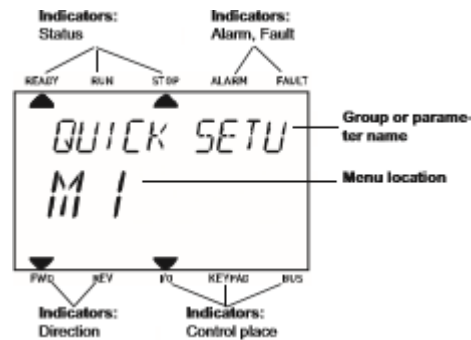

A replacement advanced commissioning keypad is available as an accessory (ACC/VSD2H GRAPHIC DISPLAY). The commissioning keypad can also be used to store the parameter settings and transport them to another drive (ref: M6.5). The top row is the drive status field, and the second row is the location field describing the position in the selection menu. The remaining three rows can be used for display of information. The commissioning keypad has extra features (help and information displays, favourites, multi-monitor of 9 selected values).

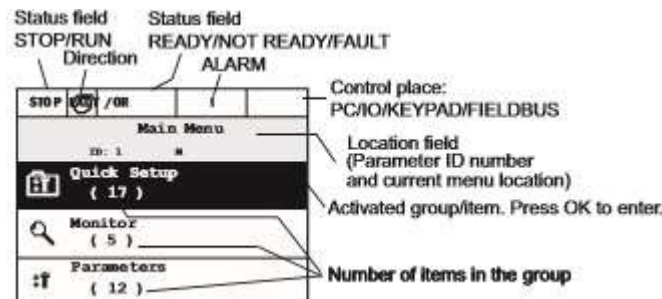

Hardware

The keypad has nine buttons which are used for controlling the drive, setting parameters, and monitoring values. The buttons are the same for both types of keypad.

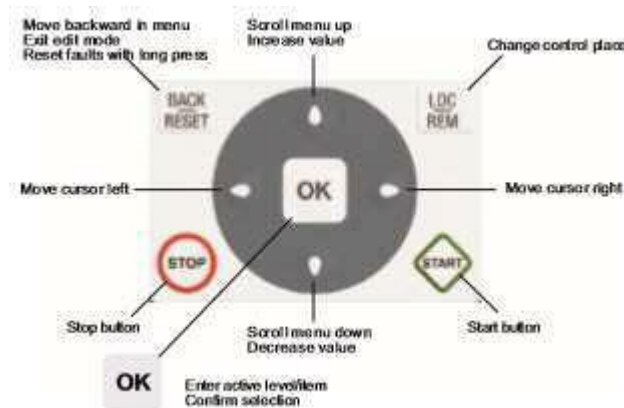

The keypad is the control source by default (i.e. Local) but it can be changed to remote at any time by pressing the LOC/REM button. (The control source has to be changed to Remote/Fieldbus for the NXNI or NXIP to control the drive.)

The main menu consists of 7 individual items which are browsed using up and down buttons, the submenus under these menus are then browsed by selecting OK.

Quick setup:

A group of the parameters most commonly used during installation and commissioning.

Monitoring: This enables parameters to be monitored only.

Parameters: This enables the parameters to be edited.

First the group of parameters is selected, then the individual parameter. The actual meanings of the parameters vary with the configuration being used.

Diagnostics: This enables current and historical faults to be viewed, faults to be reset, and counters and software information to be viewed.

I/O and hardware: This selects basic I/O, any additional boards in slots D or E (an NXNI or NXIP in slot D would be shown as OPTCO), Real time clock, the drive fan, keypad settings and fieldbus (RS485 or Ethernet) parameters.

User settings: language, application, parameter backup and restore to and from keypad.

Favourites: (Advanced commissioning keypad only) This enables the user to collect a set of parameters from any of the keypad menus.

Digital Input Isolation: The digital inputs (DI1 to DI6) can be isolated from ground by removing a link on the control board as shown

Ethernet Connection: The Ethernet connection for BACnet over iIP or MODBUS TVP is situated under the cover to the left of the control keypad, and the cable is run in a channel cut in the plastic flap. A shielded RJ45 connector should be used.

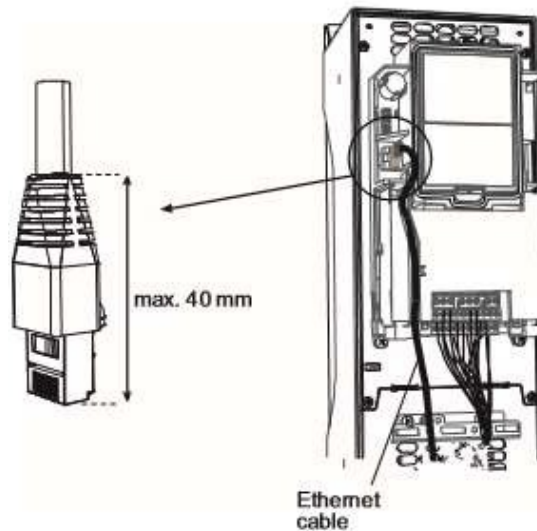

RS485 Connection: The RS485 connection for BACnet over MS/TP or MODBUS RTU uses terminals A and B (A negative, B positive) in the basic I/O board terminal set. STP (Shielded Twisted Pair), type Belden cable 9841 or similar should be used. The terminal to ground (see above DIP Sw 1) should only be switched on if the unit is at one end of the bus.

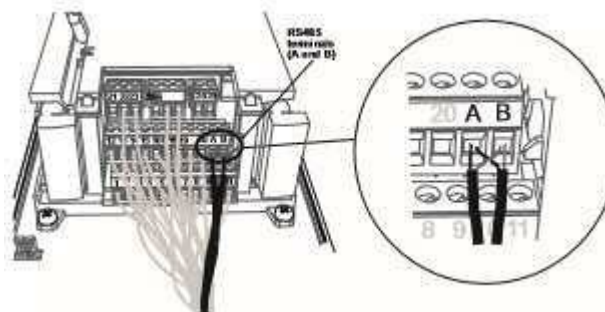

Real Time Clock: The VSD2H has a real time clock with timer functions. The unit comes complete with a Real Time Clock battery installed to maintain the time during power failure.

Integrated RFI-filter: The units have integrated RFI filters, enabling them to comply with EN61800-3 category C2 (suitable for public electricity networks such as buildings).

Integrated DC choke: The units are equipped with DC chokes to reduce harmonics (THD), enabling them to comply with EN61000-3-12.

Integrated stress removal: stress removal and 360° grounding of power cables inside the unit with clamps. No need for extra glands.

Quick Setup

On initial power up, the start-up wizard will prompt for:

- Language
- Daylight saving
- Time, day, year
- Run start-up Wizard

(Y/N) If yes:

- Process (pump or fan)
- Motor Nominal Speed (range 24 to 19200 rpm)
- Motor Nominal Current (range depends on unit)

There are other mini-wizards that can be used for setting the following:

- PID: Three term control for motor or external device by way of I/O.
- Pump and Fan Cascade: Cascade control of several pumps or fans.
- Resonance Sweep: For elimination of possible resonance points in the system.

The quick setup menu, mentioned above, enables access to the parameters most commonly used during installation and commissioning including access to the start-up, PID and pump and fan Cascade wizards.

Uninterruptible Operation and Energy Saving

Over temperature ride-through: Automatically adjusts switching frequency and/or speed of the motor to adapt to unusual increase in ambient. The benefit of this is uninterruptible operation.

RTO – Ramp Time Optimizer: When problematic areas are identified in acceleration or deceleration the drive automatically expands the times needed for this to avoid mechanical stress to the system. The benefit of this is the decreased mechanical stress to the system.

Trip free output switching: Ensures trip free operation when an output switch (e.g. safety switch) is operated between the motor and the VSD. Truly intelligent and highly reliable function to ensure better functionality than with any other VSD. The benefit of this will be Uninterruptible operation.

Energy Saving function (Flux Optimization): Flux Optimization automatically minimizes energy consumption. The benefit will be a 5% increase in energy savings.

Configurable Auto Reset function: Auto restart function can be configured to make VSD restart automatically once fault is addressed. The benefit of this is uninterruptible operation.

VFD and Motor Control

Single Input Control: Analog signal rising edge can be used to start the device without additional start signal to a digital input. The benefit of this is cost and time savings.

Flying start: Ability to get an already spinning fan under speed control. The benefits of this will be improved performance, very important in clean room production.

Automatic torque boost function: Boosts initial voltage to start high inertia fans. The benefits of this is it avoids tripping and enables smooth starts also to high inertia loads.

High Switching Frequency: The VSD2H is capable of providing the maximum power with high switching frequency. The benefit of this is low audible noise from the motor.

Prohibit frequency: Overriding the critical frequencies to avoid resonance. Can be set with the help of resonance sweep wizard. The benefit of this will be the elimination of resonance.

Maintenance counters/alarms: The drive can be programmed to notify on upcoming maintenance for the system or the drive itself. The benefit of this will be the reliability.

Temperature-controlled fans: Fan stops operating when not needed. The benefits of this is less audible noise from the VSD itself, and also energy savings.

Advanced HVAC Control

Time based control: With the help of the real time clock and calendar functionality the drive can be programmed to perform functions based on time. The benefits of this will be cost savings and also flexibility.

Inbuilt PID Controller: Normal and Inverse Regulation, Delta P regulation with 2 standard pressure transmitters, Feed forward control, less wiring since sensor normally close to inverter. The benefit of this would be the cost saving and faster response to process closed loop.

Sleep Mode: Shutting down the motor, when no demand. The benefit of this will be energy savings.

Pressure loss compensation: For compensating e.g. wrongly placed sensor in the system. The benefit of this will be a time and cost saving. **Pump Soft Fill:** Feature to prevent the overpressures when filling empty pipe work. The benefit of this will be a longer lifetime of the system.

Fire override mode: Keeps fan/pump running in case of fire. This is a legal requirement.

Pump and Fan Cascade control with full auto-change: Controls total pumping system with several parallel pumps by equally sharing the load. Also the master pump can be included in auto-change loop. The benefits of this will be the longer lifetime of the system, also the cost savings will be a benefit.

Software

Windows based PC utility tools are available for making the use of the Trend VSD2H as easy and convenient as possible. The tools facilitate installation, commissioning and maintenance. The software is self-documenting from its integral help file. The minimum requirement for using the software is a PC and a USB to RS485 interface cable (e.g. ACC/VSD2H/USB-PC/CABLE, 3 m), to be connected to the RS485 terminal behind the control panel.

Drive care PC tool: The drive Care tool is easy-to-use commissioning software for the control of the VSD2H. It enables the following:

- Setting up parameters with the PC
- Saving settings to the PC
- Creating commissioning documentation
- Comparing parameters settings
- Monitoring view with graphics
- Diagnostics
- Controlling the drive from the PC.

This tool also includes the 'Loader' tool which enables the downloading of firmware or applications.

Note that the drive configuration can be loaded from one drive into the advanced commissioning keypad (ACC/VSD2H/Graphic Display), and downloaded into another drive.

SISO – Safety Isolators/Switch-disconnectors

Switches & Sensor

Features

- Electrical range 230V-690V, 1-3 phase, 50-60Hz, 0-63A
- Enclosure IP66 Grey RAL 7035
- Mechanically interlocked with 3 x padlock to 'off' apertures
- Early breaker fitted to all units as standard. Three and six pole/wire versions available
- Three and six pole/wire versions available
- Two entries top and bottom 20/25A M20 40/63A M20/25
- Stainless steel facia screws
- Two earth continuity screws in each enclosure

Description





All fans and drives should have a correctly rated lockable Isolator switch instead in the power input circuit to provide full electrical isolation. This is vital for safe installation, operation and maintenance.

Many modern drives also require an early break signal so that a graceful full power off can be achieved without damage to sensitive electronics. Early break is included in all SISO Isolators. Isolators are provided with mechanically interlocked IP56 standard.



Range

Model	Description	Part
SIS025-3	Isolator 3P 25A+2EB	EA002000
SIS040-3	Isolator 3P 40A+2EB	EA002001
SIS063-3	Isolator 3P 63A+2EB	EA002002
SIS025-6	Isolator 6P+2EB 25A	EA002003
SIS040-6	Isolator 6P+2EB 40A	EA002004

Attribute	Unit	SIS025-3	SIS040-3	SIS063-3	SIS020-6	SIS040-6
Rated thermal current	A	25	40	63	20	40
Rated insulation voltage	V	690	690	690	690	690
Rated impulse voltage	kV	6.0	6.0	6.0	6.0	6.0
Rated operational power (3 phase AC)	kW	11.0	15.0	25.0	7.5	15.0
Rated short withstand current (1 sec)	A	500	600	1300	250	800
Terminal type						
Flexible cable	mm ²	6.0	6.0	16.0	2.5x2	6.0x2
Rigid cable	mm ²	10.0	10.0	25.0	2.5x2	10.0x2
Tightening torque	Nm	1.2	1.2	1.2	1.0	1.0

Auxiliary Contacts			
Rated insulation		V	690
Rated thermal current		A	10
Operational current	100V	A	8
	220-240V	A	8
	380-400V	A	3
	660-690V	A	1
Max. conductor size		mm ²	1.5
Tightening torque		Nm	0.6

Commissioning

Plate Exchanger Aluminium

Before commissioning, ensure that the air streams can flow freely through the plate heat exchanger. If dampers are fitted, check their movement and correct adjustment.

Furthermore check if installation has been carried out correctly and make sure the application limits (temperature, pressure difference, material etc.) cannot be exceeded.

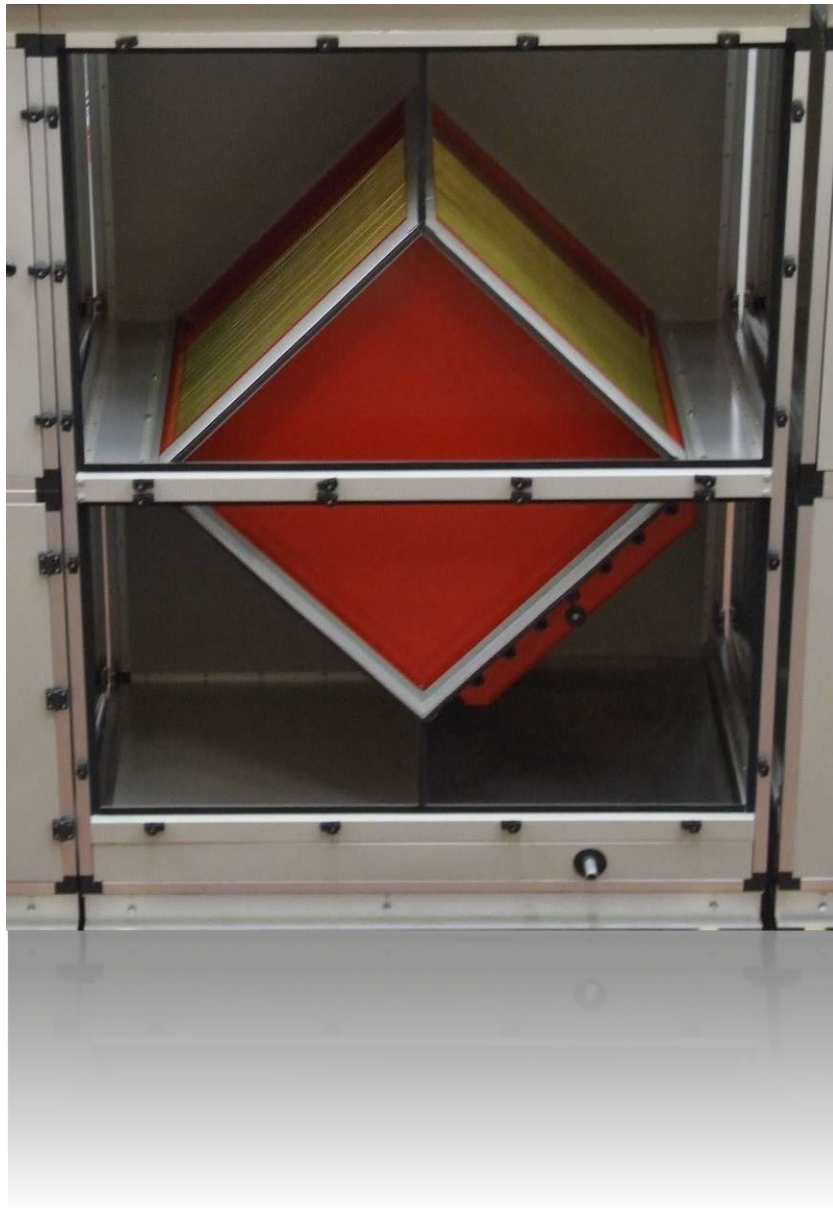

Plug / SISW / DIDW Fans - Motors – Drives

Access is by hinged or lift off panels. Catches are hidden quarter turn cams, tool or key operated.

Wiring to the motor(s) should be carried in flexible armoured conduit through screwed gland(s) fitted in holes(s) drilled by the installer/user. NEVER THROUGH ACCESS DOORS.

Motors may be 240/1/50 or 415/50 TEFC, flameproof, super silent, single speed, dual speed, regulative or non-regulative D.O.L. or Star Delta. DO NOT attempt to wire the motor without reference to the correct wiring diagram issued with the unit.

Starters MUST have thermal overload cut outs and single phasing prevention devices.

Belt Drives

Slacken belt tensioner, remove belts, check impeller rotates freely and fan scroll is free of obstructions. Remove locking bolts and shipping braces, if fitted, to protect vibration isolators during transport.

Adjust jacking self-levelling steel spring vibration isolators as instructions until floating and damped. Check rubber in shear anti-vibration mounts for condition, tightness and free operation –bounce.

Inspect all bolts on motor, fan and frame for tightness. Test run motor for condition and correct rotation.

Replace belts and check pulleys are correctly aligned as illustrated.

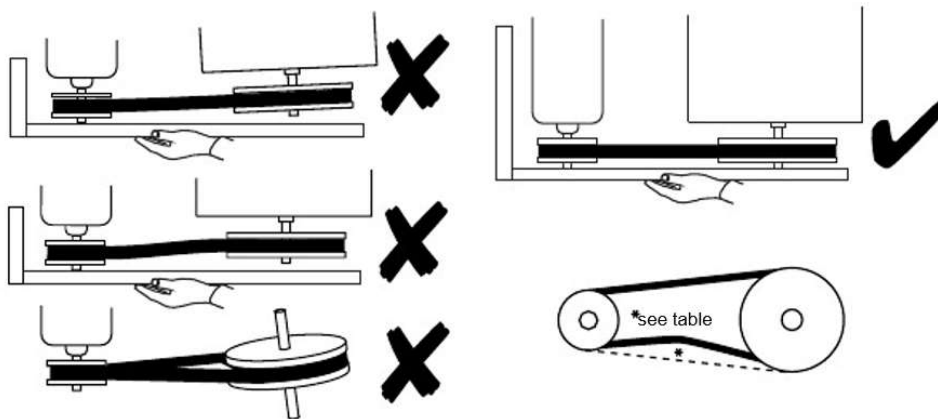

Adjust the belt tension according to the table

The lowest belt tension at which slip does not occur under load gives longest belt and bearing life.

Belt Section		SPZ	SPZ	SPA	SPA	SPB	SPB	SPC	SPC
Small pulley diameter	Min	67	100	100	140	160	236	224	375
	Max	95	140	132	200	224	315	355	560
KG force for 16mm* defl'n / metre span	Min	1.0	1.5	2.0	2.8	3.5	5.1	6.1	9.2
	Max	1.5	2.0	2.7	3.5	5.1	6.6	9.2	12.2

With all access panels in place, components installed and the cutting system complete, connected and commissioned, check that measured full load current is less than motor nameplate full load current. Check that starter overload setting is correct and that single phasing protection is functioning. If any problems occur refer to Fault Finding Section of this manual.

The complete ductwork system should be proportioned to CIBSE - ASHRAE recommended procedure. The Volume should be measured and if outside CIBSE recommendations or specified tolerances then;

Installer / commissioning engineer should submit full commissioning data to ECE.

ECE will calculate new fan speed required to achieve design volume and recommend pulley(s) & belt(s) sizes required to achieve new fan speed.

Installer/commissioning engineer should then:

- Purchase new pulleys and belts available locally from nationwide stockiest.
- Change pulley(s) and belt(s) on site
- Re-measure volume
- Recheck proportion and volumes to air terminal devices

ECE site operatives are available for changing belts and pulleys on site at extra cost if required.

"Rotating standby motors generate electricity even when isolated from the mains. If the motor is being rotated by the fan do not touch the terminals even if the motor is isolated"

The most common cause of incorrect fan volume is over estimation of system resistance. Please check this before contacting ECE.

Unless specified otherwise fans are belted to give specified volume with clean filters.

Where the specification calls for design volume with dirty filters we recommend the incorporation of pressure activated constant volume control since selection of the fan(s) at final system resistance could result in considerable excess volume initially.

Excess volume can cause:

- Coil off temperature, hence room supply air temperature, hence room temperature not being achieved
- Water carryover and flooding
- Motor overload and burnout
- Increased fan noise levels
- Turbulence and excitation of duct walls resulting in noise and vibration problems
- Noise regeneration at changes of direction, volume control dampers and air terminal devices
- Reduced filter life

Gross under volume can cause coil sweating, freezing and motor burn out.

Anti-Vibration Mountings Rubber Mountings

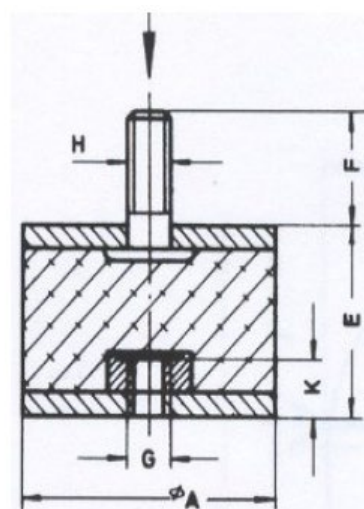

A	E	G	H	F	K
20	25	M6	M6	15	6
25	15	M6	M6	18	6
25	20	M6	M6	18	6
25	30	M6	M6	18	6
30	30	M8	M8	20	8
40	30	M8	M8	23	8
40	40	M8	M8	23	8
50	35	M10	M10	28	10
50	40	M10	M10	28	10
50	50	M10	M10	28	10
75	50	M12	M12	37	12
100	40	M16	M16	45	16

Spring Mountings

Isotop® SD steel spring vibration isolators consist of two spring elements with M 10 internal thread and a cylindrical screw spring designed according to DIN EN10270-1: 2001. Height adjustment is done via a threaded rod M 10 with three nuts and three locking washers for level adjustment and weight distribution. Corrosion protection: Optional corrosion protection, either galvanized or cataphoresis coated (KTL).



Isotop SD, galvanized



Isotop SD KTL

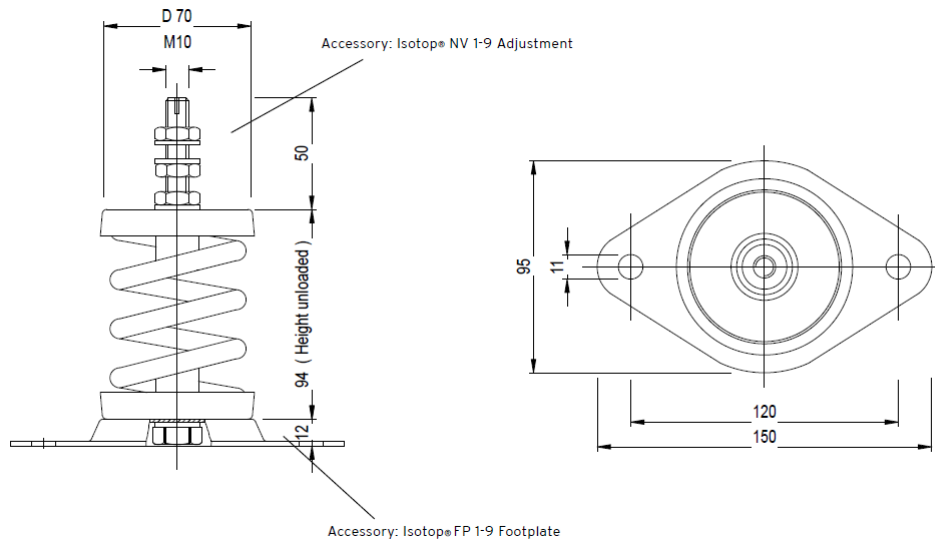

Selection Table

DESCRIPTION	REF. NO., GALVANISED	REF. NO., KTL (BLACK)	NOMINAL RANGE min./max.	SPRING RATE
Isotop® SD 1	45000011	45000001	120 N – 265 N	7.93 N/mm
Isotop® SD 2	45000012	45000002	195 N – 380 N	12.90 N/mm
Isotop® SD 3	45000013	45000003	300 N – 670 N	20.16 N/mm
Isotop® SD 4	45000014	45000004	475 N – 1,200 N	31.64 N/mm
Isotop® SD 5	45000015	45000005	720 N – 1,700 N	48.07 N/mm
Isotop® SD 6	45000016	45000006	1,130 N – 2,700 N	75.56 N/mm
Isotop® SD 7	45000017	45000007	1,815 N – 3,800 N	121.03 N/mm
Isotop® SD 8	45000028	45000008	2,800 N – 5,200 N	187.10 N/mm
Isotop® SD 9	45000029	45000009	3,750 N – 6,400 N	234.30 N/mm

Checking Label Positioning



The positions of the Danger & Caution labels, these labels will always be positioned on the fan section doors. Should for any reason these labels not be in position they can be obtained from ECE



The positions of the Caution Hot Surface labels, these are positioned on electric heater batteries and gas burners where the surface on the outside of the AHU will be HOT. Should for any reason these labels not be in position they can be obtained from ECE

Hinged Handle Access

When working internal to the AHU you must remove the access doors completely to stop personnel getting locked inside.

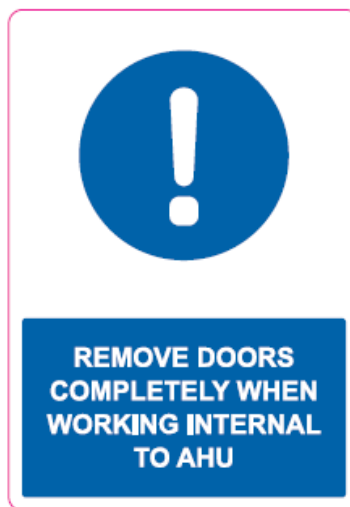

Compression Latch-Hinge

Product Details

- When the door is closed, the latch is adjustable (3mm) to achieve perfect alignment
- Compression (5 mm) with low opening & closing force
- Door or panel can be removed by unlatching the handles on both sides
- Right or left hinged
- Hinge 180° opening angle
- Available with or without pressure relief

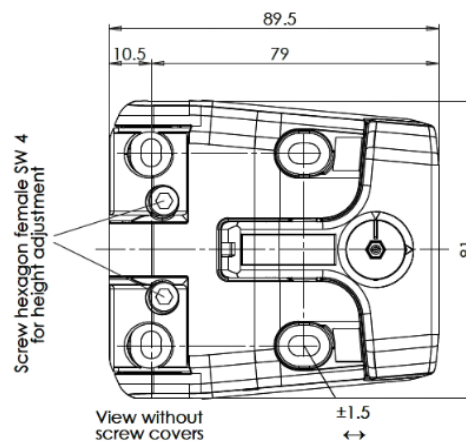
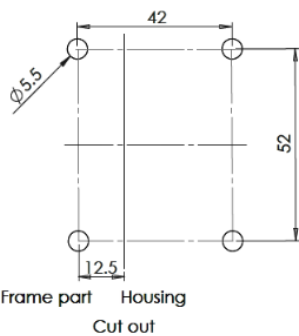
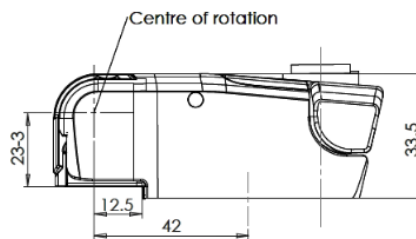
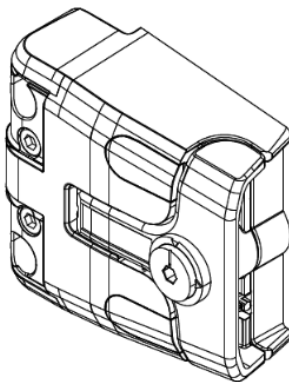

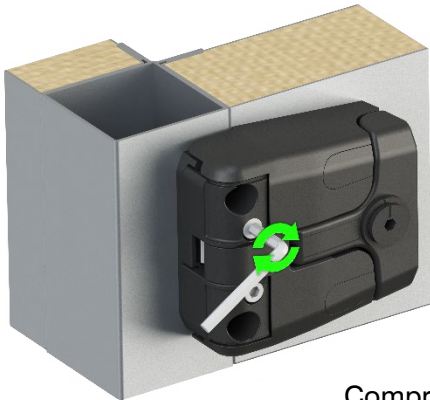

Compression
Latch-Hinge locked

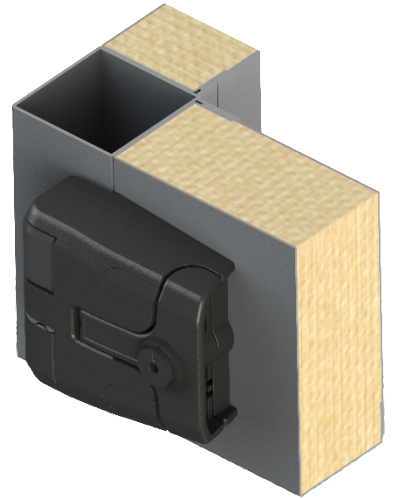

Compression adjustable
on the frame part

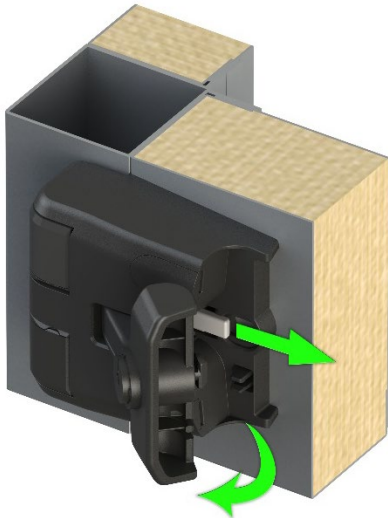

Latch-Hinge with pressure
relief, handle unlocked

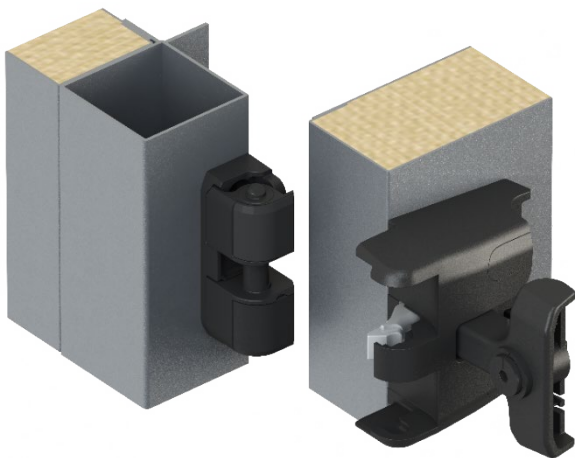
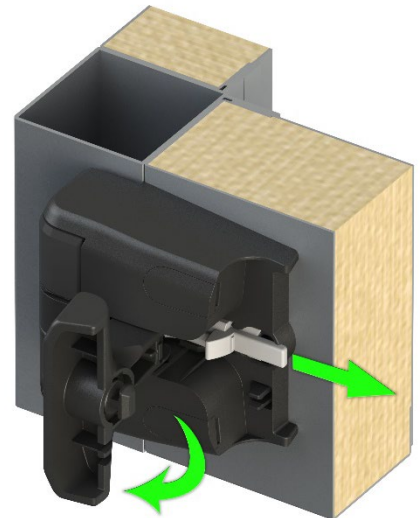

Latch-Hinge open

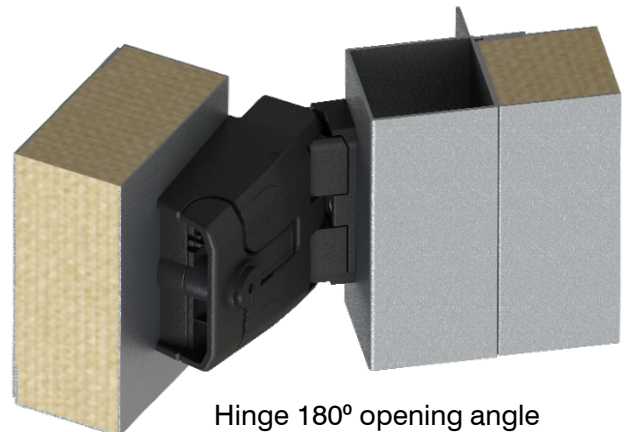

Hinge 180° opening angle

Servicing Filters

- Remove open side access doors (unless special access).
 - Thoroughly clean system.
 - Install temporary filters (gauze bags etc) on inlet discharge points.
 - Replace and close access doors.
 - Blow out system.
 - Remove contaminated temporary filters.
 - Replace filters, check sealing for bypass.
 - Replace doors.
- ✓ Panel filters - Check airflow direction arrows.
 - ✓ Absolutes - Ensure pre-filters fitted, check sealing.

Maximum operating conditions	Continuous	Short period
Glassfibre panels	110°C 80% RH	110°C 80% RH
Soft fibre panels	49°C 80% RH	49°C 80% RH
Bag standard	100°C 80% RH	100°C 89% RH
Bag extra fine superfine	100°C 100% RH	100°C 100% RH
Fire resistant panel (BS.2963)	250°C	500°C
Absolute corrosion resistant	66°C 100% RH	120°C
Absolute medium temperature & humidity	70°C 80% RH	120°C
Absolute fire resistant & self-extinguishing	250°C 100% RH	500°C

Always replace media with IDENTICAL media.

Install fan run-on control with high temperature heating mediums such as steam or electricity.

Pressure switches across filters only indicate blocked filters NOT low airflow due to other reasons e.g. blocked inlets dropped fire dampers.

Install bag or absolute filters after the fan (with discharge plenum) to guarantee efficiency. Pre filters are still necessary to protect the coils. Activated carbon filters must have coarse and fine pre-filters.

Mixing Boxes - Separation Boxes - Shut off VCD's - HRD's



Hand operated with locking quadrant

Check:

- Free action of the damper blades and arm before setting at the required angle.

Motorised

Remove links and check:

- Motor bolts and platform tight.
- Electrical supply and connections correct.
- Motor operates freely and in correct direction.
- Dampers move freely.
- Reconnect link(s) and adjust for required damper movement and check
- Links are not adjusted so that motor attempts to push dampers BEYOND fully open or fully closed position in as this can damage motor linkages and bearings.

Coils

General checks:

- Coils installed in correct order for psychometrics.
- Fin conditions, comb out if necessary.

Water coil checks:

- Air and water are in counter flow.
- Flow pipe work with drain cock fitted is to lowest connection.
- Return pipe work with vent is from highest connection.
- Drains at the lowest point, vents at highest point.
- Frost protection exists for low ambient airflow or shut down conditions.

Coil Connections

Ensure connections to coils are bottom inlet and top outlet, this arrangement ensures thermal siphoning aids flow. Performance will be limited if these connections are made the wrong way.

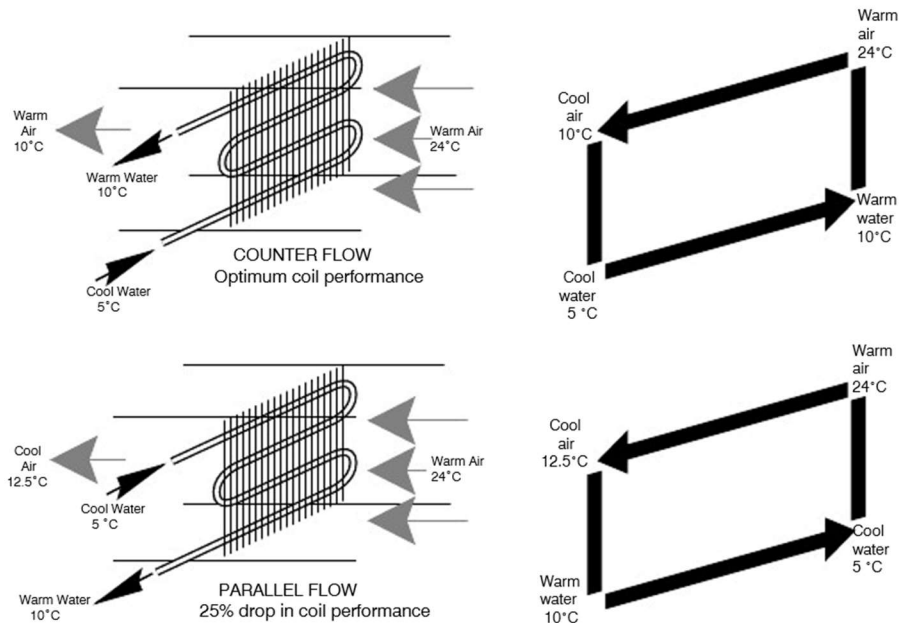

Refer to following section for full details on coil and condensate drain connections

Setting Water Flow through Coils

Open all manual valves fully – including the bypass valve on the three port control valves diverting port. Ensure that the three port control is set to pass 100% flow through the air handling unit coil.

With the aid of a screwdriver open the two small inbuilt valves either side of the flow indicator window on the main commissioning unit. The main commissioning unit is sited in the main return pipe (these small valves allow water to pass through the indicator window to enable flow rate to be observed).

Set the flow rate through the coil by rotating the larger valve on the main commissioning unit to restrict the water flow until the desired flow rate is indicated in the window. Once this valve has been set DO NOT adjust it again.

Move the three port control valve into the 100% bypass position.

Slowly close the secondary commissioning valve (sited on the three port control valves bypass port) at the same time observe the flow rate being indicated in the window of the main commissioning valve. Continue closing this valve until the same flow rate reading as before is obtained.

Conclude by closing the two small integral valves wither side of the indicator window on the main commissioning valve.

The system is now balanced.

Coil Condensate Drains

Draw Through Units and Blow Through Units with negative pressure (depression at trap)

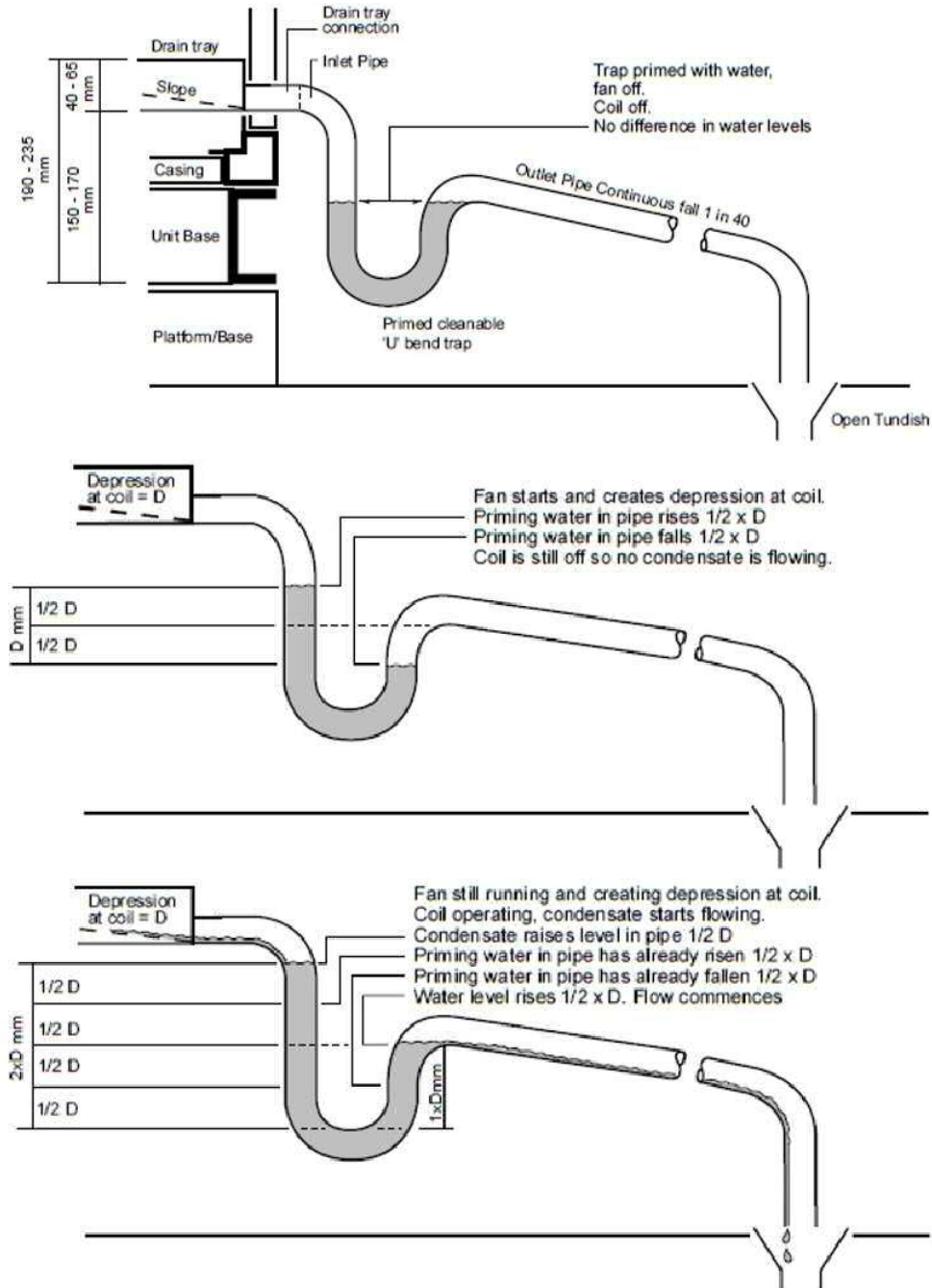

10pa difference in pressure = 1mm difference in water level
i.e. 190mm = 1900pa depression -- 235mm = 2350pa depression

Blow through units with positive pressure at trap

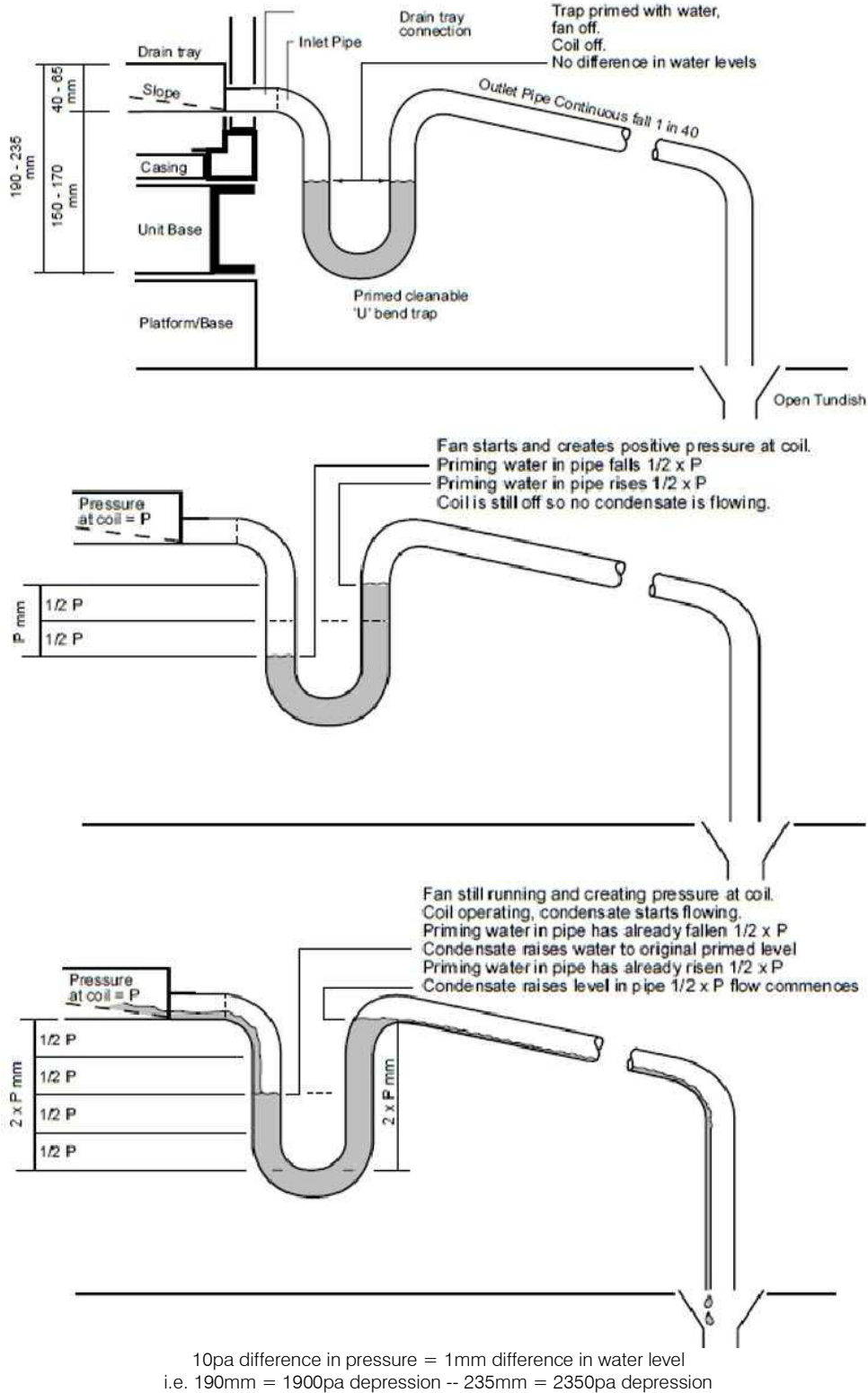

Coil Condensate Faults

Draw Through

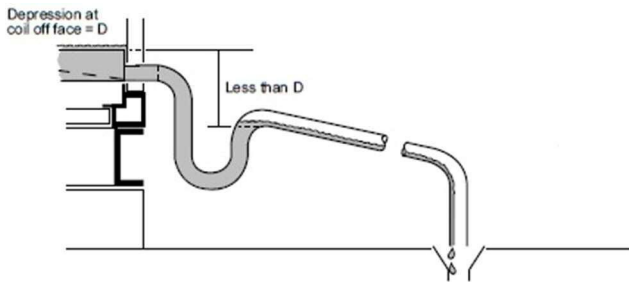

Inadequate trap differential resulting in condensate drain tray overflow and flooding

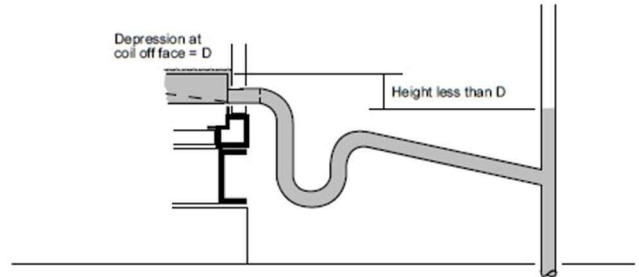

Not draining into an open tundish but connecting to a full pipe resulting in condensate drain tray overflow and flooding

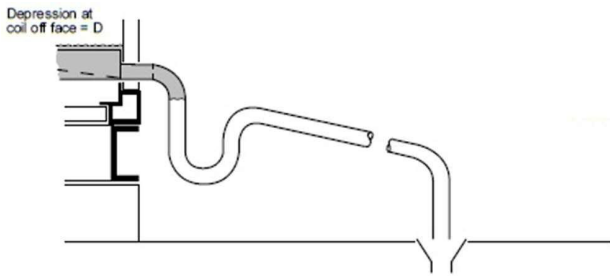

Trap not being primed with water resulting in condensate drain tray overflow and flooding

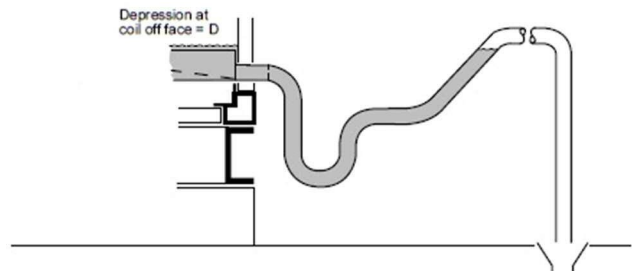

Reverse pipe slope resulting in condensate drain tray overflow and flooding

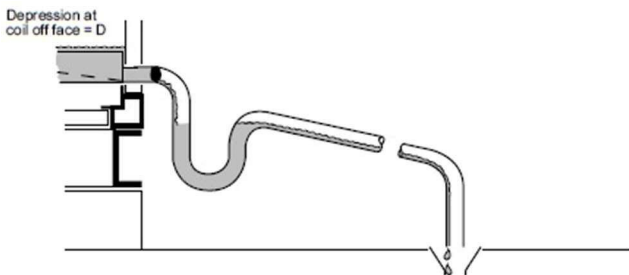

Blocked pipe connection(s)
Partial block = some flow resulting in condensate drain tray overflow and flooding

Blow Through

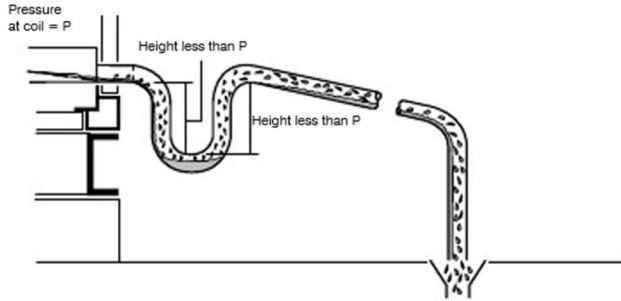

Inadequate trap differential resulting in priming water blow-out "splutter" and air leakage

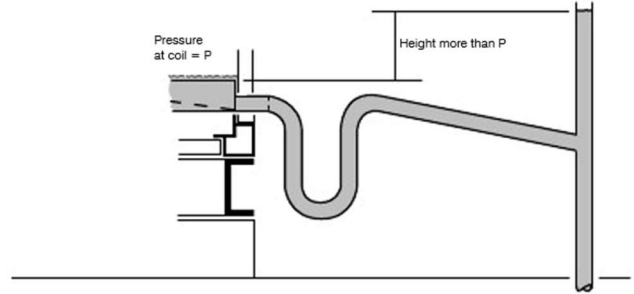

Not draining into an open tundish but connecting to a full pipe resulting in condensate drain tray overflow and flooding

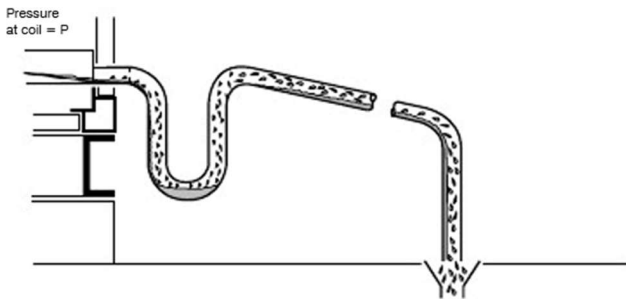

Correct trap but not primed with water resulting in condensate blow-out "splutter" and air leakage

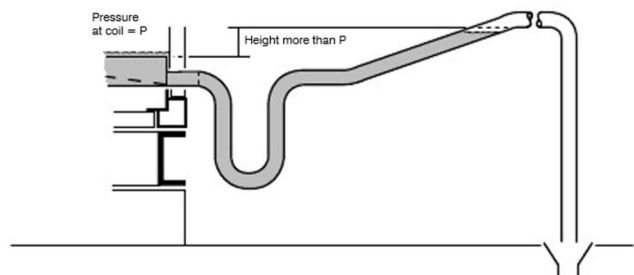

Reverse pipe slope resulting in condensate drain tray overflow and flooding

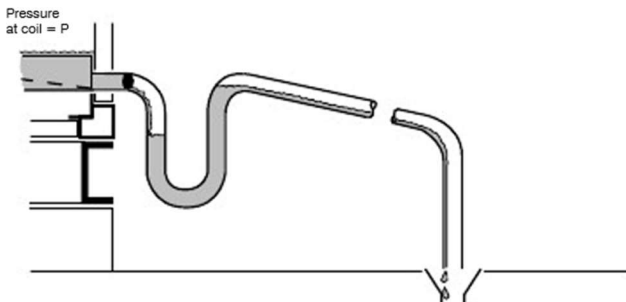

Partially or fully blocked pipe connection(s) resistance through blockage greater than P resulting in drain tray overflow and flooding.
Partial block = some flow

Draw through coils with condensate pump

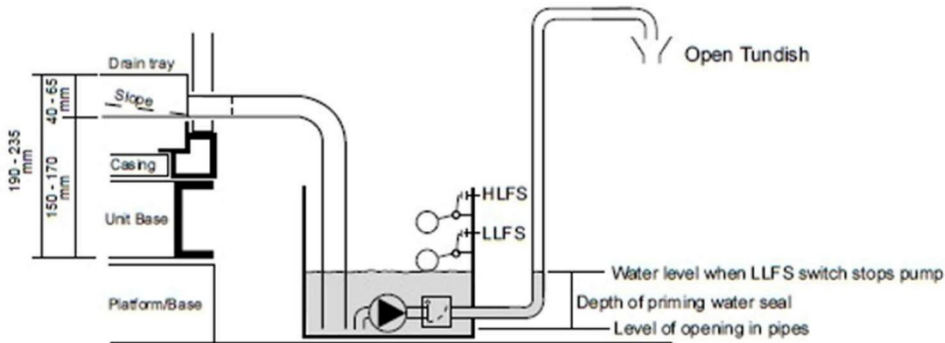

Pump sump primed with water
Fan off
Coil off
No difference in water levels

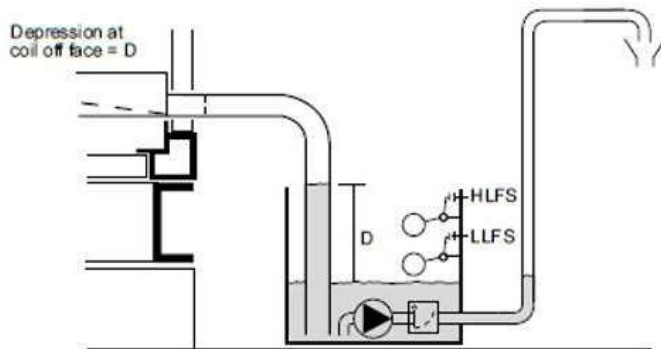

Fan starts and creates depression at coil
Priming water in pipe rises $1 \times D$
Priming water in sump falls
$$1 \times D \times \frac{\text{Area of pipe}}{\text{Area of sump}}$$

Coil is still off so no condensate is flowing

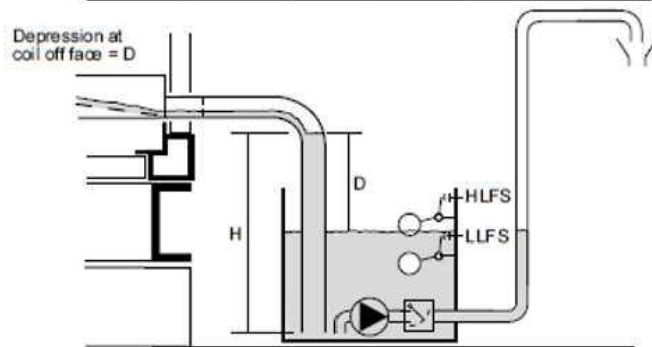

Fan still running and creating depression at coil
Coil operating, condensate flowing
Water level in pipe rises
Water level in sump also rises until HLFS operates
Pump starts

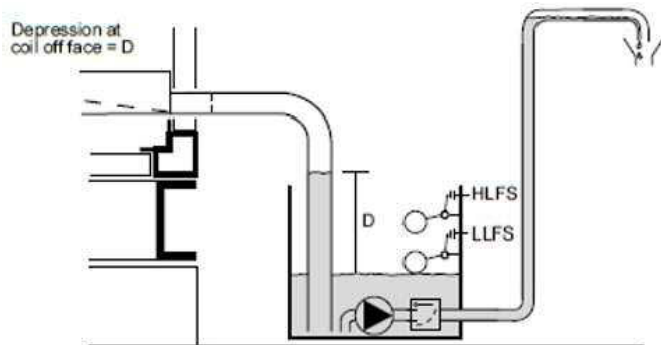

Pump runs
Water levels falls until LLFS breaks
Pump stops

H = depression at off face of cooling coil + difference in level between HLFS operating and pipe openings
10pa difference is pressure = 1mm difference in water level
i.e. 1900pa depression - 235mm = 2350pa depression

Chilled Water Cooling and LP Hot Water Heating Coils

Bypass Circuit

Tightly closing three-way valves are required as the regulating valves. At nominal flow the pressure drop across the valves (pv100) should range from approximately the same value to about double the value of the pressure drop across the heating load branch at nominal flow.

The balancing valves are used to adjust the water volumes for the individual heating circuits.

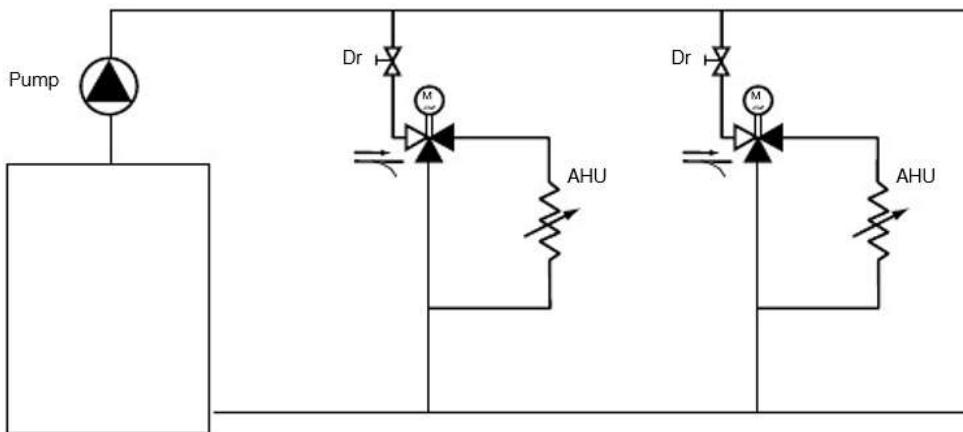

Mixing circuit using three-way mixing valves.

Slipper valves can generally be used. The nominal size is usually chosen equal to the nominal size of the pipe. However, from the point of view of hydraulics, slipper valves one size smaller than the nominal size of the pipe are preferable.

In systems where the pressure difference between A and B exceeds approximately 0.8 mWG, it must be checked that the leakage losses of the slipper valves remain within tolerable limits. If this is not the case, seat valves are to be used.

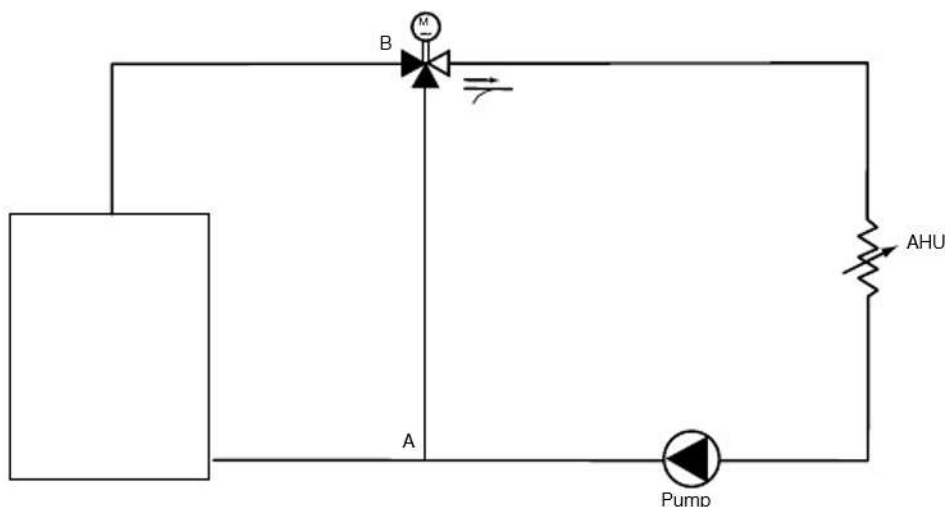

Chilled Water Cooling Coils

Coils are normally of open header box construction (but may have split end covers supplied to order) are completely self-supporting and designed to be fitted directly between or within the sections of the air handling unit.

When split cover plates are supplied these should be removed prior to connections being made, then replaced. Great care should be taken when tightening connections to avoid damage to the coil. The space between the pipe work and cover plates should be sealed with a grommet or similar.

A correctly sized thermostatic expansion valve with external equalising connection must be fitted.

Run the liquid refrigerant line to the TEV which should be fitted to the liquid distributor, feeding the individual circuits of the evaporator coil.

An adequately sized suction line should be run from the suction head to the compressor.

The valve equalising line should be run to the suction line on the compressor side of the valve sensitive phial which should be placed on top of the suction line periphery and secured with a special slip.

A suction liquid heat exchanger should be used to improve the performance of the expansion valve and utilise the complete coil surface.

If your unit is built to HTM standard each coil will come with a removable drain tray. A screw connection joins the tray to the drain line, which can be detached so the tray can be removed and washed down.

A correctly sized sloping drain line with a cleanable "U" bend water trap terminating at an open drain or tundish should be run from each drain connection.

Hot Water Heating Coils

Coils are normally of open header box construction (but may have split end covers supplied to order) are completely self-supporting and designed to be fitted directly between or within the sections of the air handling unit.

When split cover plates are supplied these should be removed prior to connections being made, then replaced. Great care should be taken when tightening connections to avoid damage to the coil. The space between the pipe work and cover plates should be sealed with a grommet or similar.

A correctly sized sloping drain line with a cleanable “U” bend water trap terminating at an open drain or tundish should be run from each drain connection.

Heater coil automatic control valves should be wired into the fan starter circuit so that valve motors close when fan is stopped. This prevents temperature build up within the unit and possible harm to motor windings, particularly important with high pressure hot water or steam coils.

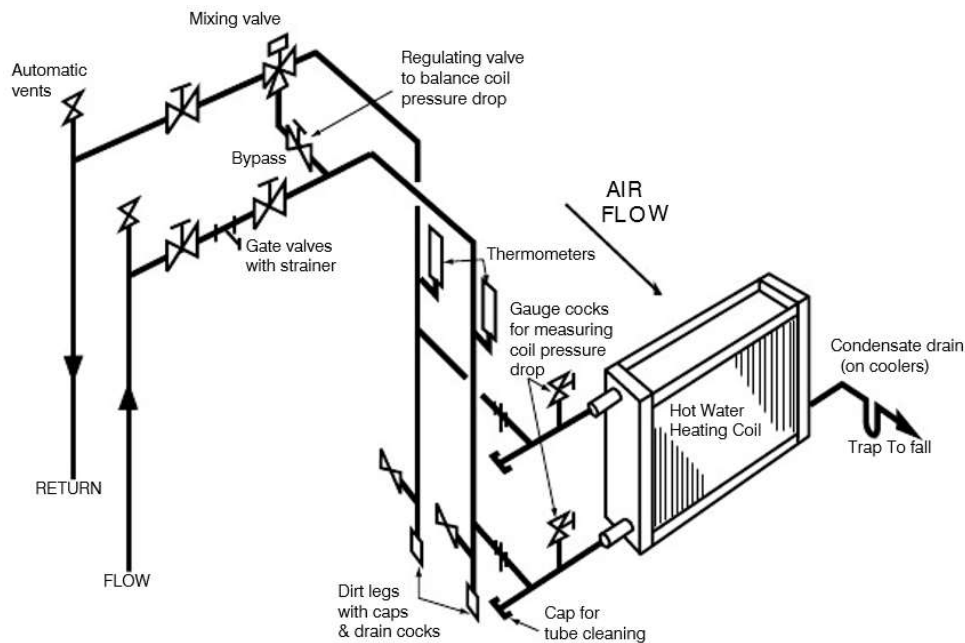

A typical piping arrangement for hot water heating coil

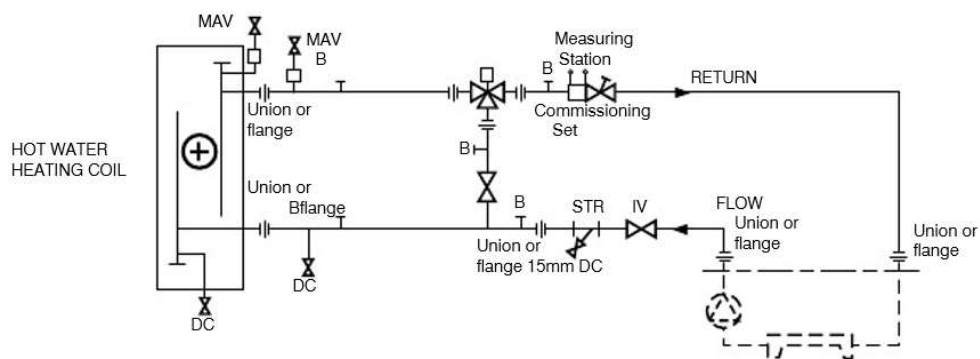

A typical schematic for hot water heating coil

Steam Coils

Coils are normally of open header box construction (but may have split end covers supplied to order) are self-supporting and designed to be fitted directly between or within the sections of the air handling unit.

When split cover plates are supplied these should be removed prior to connections being made, then replaced. The space between the pipe work and cover plates should be sealed with a grommet or similar.

Check:

- Supply is under 100 PSIG dry.
- Supply is free of air and connected to the top coil connection.
- Connecting pipe work is not supported by coil.
- Expansion allowance made for coil tubes.
- Connections are free from stress and are properly pitched and drained (to avoid water hammer).
- Condensate connections to the steam trap are the same size as the coil outlet.
- Condensate in the main is independently trapped on a coil bypass.
- The steam trap is sized on 3 times the design flow.
- Float or bucket type traps should be carefully selected to suit the steam pressures and temperatures with thermostatic air relief traps on low pressure systems and continuous venting petcocks on medium and high pressure systems.
- Multiple or banks of coils must be individually trapped to meet the demands of the varying capacities and pressures on each section.
- Selection of control valves must be based on the steam load and not the size of the steam coil supply connection.
- Automatic steam control valves are suitable where the condensate is returned to atmospheric pressure or under vacuum.
- They are not recommended on systems where pressure is maintained on the return lines.
- Steam pressure in the coil is not used for lifting condensate.
- If coil is near filter ensure fan runs on after steam supply is cut off (2 minutes).

Note:

- Over tightening connections damages coils.
- Initial rapid heat build-up causes damage to coils and associated pipe work, valve opening must be gradual.
- Check for leaks on initial start-up and after a short period of operation.

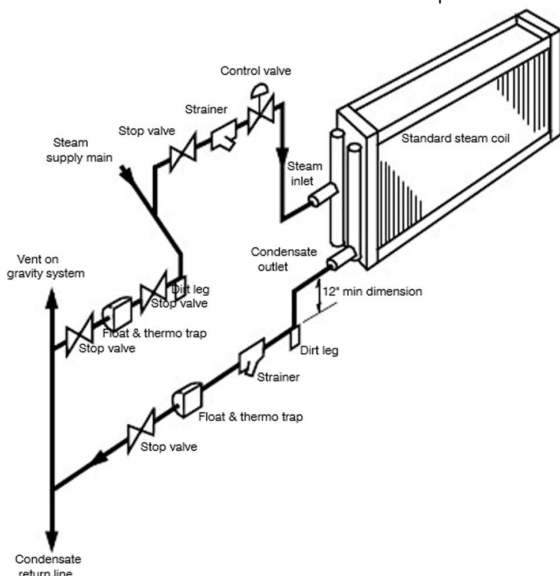

A typical piping arrangement for low pressure steam or vacuum system

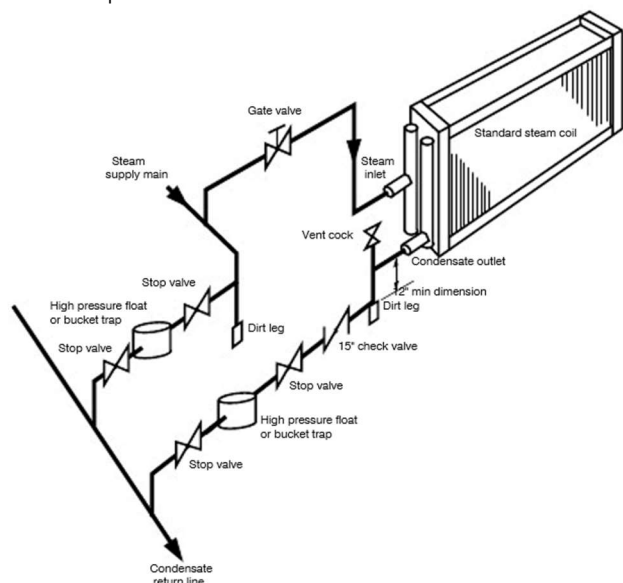

A typical piping arrangement for high pressure steam system

Electric Heater Batteries

“If not properly installed and controlled EAHB’s are dangerous. They can cause serious injury or death and start fires. Ask your local electricity board fire officer and engineers department to inspect your installation before use”

Access is by the access door clamped on the side of the unit. Cable entry should be made by drilling a suitable hole in the folded angle corner posts. Screwed glands with cable holding devices should be used at all drilled holes. Do not use P.V.C. cable inside the unit.

Generally elements are intended for phase to neutral connection balanced across 415/3/50 supply e.g. 3 elements phase to neutral stage. Before connecting out of balance loads consult with your local electricity board.

All wiring must be to I.E.E. regulations and conform to all local and national statutory requirements.

A high temperature S.P.D.T. cut out which opens at 165C is fitted, and must be wired in line with the coil of the main EAHB contact breaker. Should this cut out operate, the cause must be ascertained before the hand reset is pushed back in, since the elements may rise to 600C in still air causing filter damage, motor burn out and fire damper link failure etc. etc.

An airflow switch rated at the correct minimum velocity must be fitted (a filter pressure differential switch is NOT suitable).

Fan interlock with the EAHB and fan overrun (of up to 10 minutes after heater battery off depending on EAHB bank size) must be fitted together with automatic recycle to zero load on step controller.

Always ISOLATE the supply before removal of access door and REPLACE the access door before reconnection of supply.

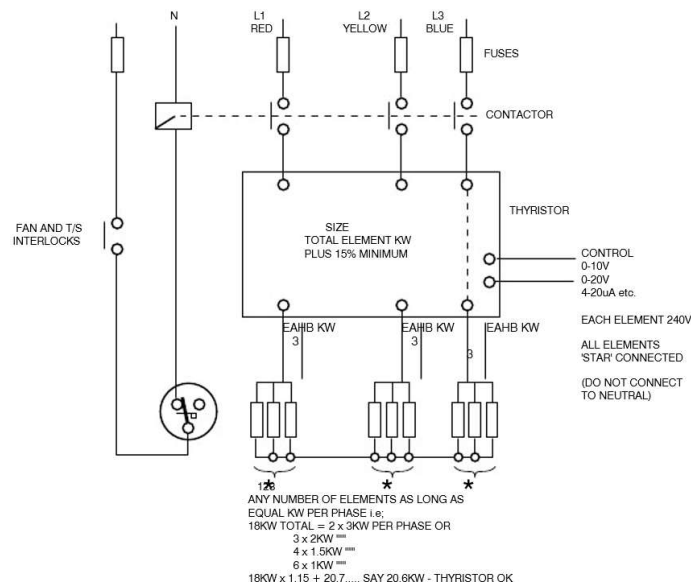

The element tray must be earthed.

Typical schematic for electric heater battery

Gas Fired Heaters

Safety Notes:

- Commissioning is recommended by our operatives, in any event gas piping, flue, electricity supply and controls should comply with gas safety, gas region, local authority, fire authority and insurance company regulations.
- Do not locate in presence of chlorinated or corrosive vapours, in areas of high risk i.e. cellulose spraying, near combustible materials or where atmospheric depression i.e. an area with extract fan or system, could cause gas reverse flow into area.
- Ensure 24" minimum clearance all round this section.
- Do not obstruct or modify build in diverter.
- Except for servicing never switch off the power supply to the unit.

Internal Safety controls comprise:

- Main gas valve closure if pilot light out
- Fan on delay unit burner warm.
- Gas off on overheat.
- Fan off delay until burner cool.

External services required:

- Natural gas supply
- Combustion air supply
- Combustion gas flue
- Electricity supply for controls
- Electricity supply for motive power

Flue gas discharge:

- Flue gas leaving the top spigot at 260deg C should be vented to atmosphere using a gas board approved flue terminal via a properly sized, individual, VERTICAL, natural draught flue rising 1.8m min.
- Unavoidable horizontal runs (max 3m) should slope 65mm in 300mm and have final verticals riser of 1.5 times the horizontal run. If these conditions cannot be met then factory installed fan assistance should be considered. If condensation is possible it should be avoided by using double skinned flue with special joiner and spigot (consult your local G.A.). If condensation still occurs a non-corrosive 22mm (min) drain should be fitted.

External controls required are:

- On/off switching (time clock start/stop, thermostat controlling burner)
- Normal electrical controls (fan motor starter, contactors and overload isolators etc.)

Wiring:

- Refer to appropriate diagram supplied with unit and not the following:
- Switching must be by individual 24V controls to each unit and should incorporate a 24V thermostat, switch and time clock in series.
- Never apply higher voltages (240V supply to motor of time clock must be separate).
- Power into the control box can only be 220V I phase 50c/s.
- Single phase fan motors up to 0.5kw (0.7 h.p.) can be connected via thermal overloads direct to the box.
- Over 0.5kW single phase and all 3 phase motors must have separate electrical supplies controlled from the box via a 240V contactor relay and should be protected by thermal overloads. Inspection prior to initial start up

Gas shut off valve closed:-

- Check all electrical functions - fan motors, room thermostat and gas control set/automatic gas safety system.
- Check correct rotation of fans.

Gas shut off valve open:-

- Carefully vent and check all gas lines for leakage by soapy water testing.
- Close gas shut off valve.

Initial start up

- Switch on main switch
- Supply air discharge(s) open
- Room thermostat "off" lowest setting
- Time switch at "on" period
- Turn on main gas
- The unit will now start
- Refer to user manual supplied with gas heater unit for details start up procedure.

Electronic Steam Humidifiers

Humidifiers supplied for use with ECE units are electrode boilers which operate at atmospheric pressure and utilise standard water supplies provided the local regulations regarding connection of this type of equipment are observed. If local regulations call for the use of a break tank to feed the unit, the speed at which the humidifier cylinder fills will be determined by the head pressure available. The size of tank, its height and the size of its connecting pipe work must be chosen carefully to ensure the unit always receives an adequate water supply. A built in flow regulator compensates for pressure fluctuations.

Water - drain connections

- Standard unit inlets are supplied with 15mm brass compression fittings.
- Drains are brass couplings of 1.5" BSP male thread and 1.25" BSP female thread sizes.

Power Supply

- Connect using conduit entry glands through appropriate knockouts in casing.
- Wiring should comply with the relevant local regulations using appropriately sized circuit breakers.

Control connection

- When step control or modulation is required, the boiler, services and controls are mounted in a cabinet which may be fixed to the side of the air conditioning unit or to an adjacent vertical surface **BELOW** the sparge pipe level.
- When on-off switching only is required the boiler and its services may be mounted inside the air conditioning unit with the control panel remote.

Start up

- Close electrical panel
- Turn on water supply to humidifier
- Close circuit breaker feeding power supply to humidifier
- Put run/drain switch into the "RUN" position
- Put on/off switch into the "ON" position
- Humidifier will now operate to the demands of the control circuit.

Operation of typical electronic steam humidifier

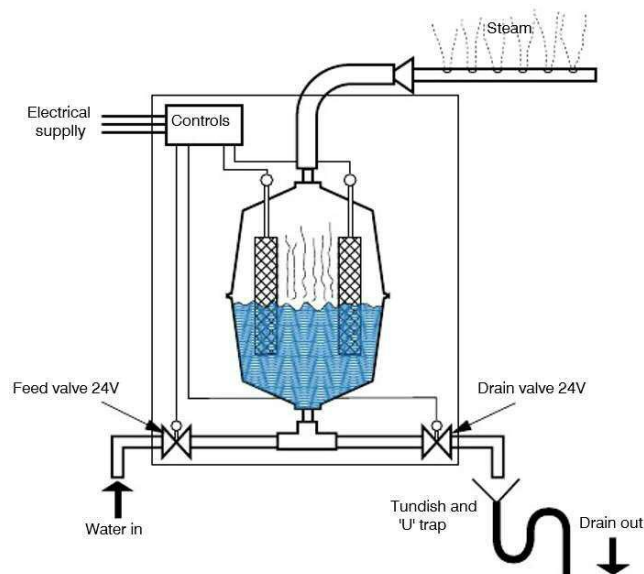

RLM Commissioning Safety Checks

- It is to be checked whether all mechanical and electrical safety devices have been fitted and connected.
- Protection devices have to be fitted in accordance with DIN EN ISO 13857!
- The ducts and the fan must be checked for foreign bodies (tools, small components, building debris, etc.)
- The idle running of the impeller must be checked by hand.
- The power setting, voltage and frequency for the mains connections must be checked against the fan or motor type plate.
- Connected control devices must be checked for functioning.
- Check the parameter settings at the frequency inverters for the PM motors (see 6.6).
- Inspection openings (if they exist) must be closed.



The fan may only be commissioned if all the safety devices have been fitted and if it is ensured that the impeller has been safeguarded according to DIN EN ISO 13857!



The suitability of protection devices and their fixtures to the fan have to be evaluated within the complete security concept of the installation.



When operating with a frequency inverter the system of fan-motor-inverter can generate increased vibrations within certain frequencies or fan rpm-areas. Operation in such an area must absolutely be avoided!

When putting the fan into operation this type of eventually occurring resonance rpm have to be determined and to be blinded out. Matching frequency inverters have to be set and operated according to the instructions given by their manufacturer. Non observance of these instructions may cause a destruction of the fan!

Test Run

The fan should be switched on briefly to check that the direction of rotation of the impeller agrees with that indicated by the arrow. In the event of the motor running in the wrong direction the poles are to be changed over while observing the electrical safety instructions.

Checking the current consumption

CAUTION

On reaching the operating speed of the fan immediately measure the current consumption and compare it with the nominal current on the motor or fan type plate. In the event of a substantial overcurrent switch off immediately.

Check for quiet running

CAUTION

Check on the quiet running of the fan. There should be no unusual rocking or vibration. Check for untypical bearing noises.

Flow measuring device

The fans are equipped with a flow measuring device as standard. With the flow measuring device it is possible to measure/monitor the flow easily after the fan is installed.

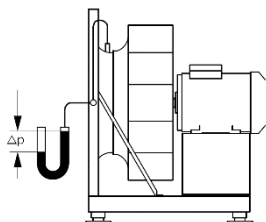

q_v volume flow m^3/h
 K calibration factor m^2s/h
 ρ density of media kg/m^3
 $\Delta p_{Dü}$ pressure difference at cone Pa

$$q_v = K \times \sqrt{\frac{2}{\rho} \times \Delta p_{Dü}}$$

When fans are built in a plenum, it is required to measure the differential pressure between the static pressure in the plenum on the suction side and the pressure at the inlet cone.

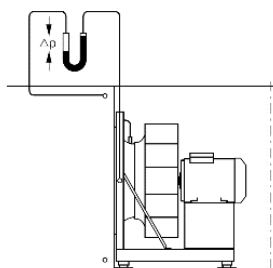

To ensure that the static pressure to be measured at the inlet nozzle is not distorted by dynamic velocities, it is recommended to attach a ring of points on the wall as shown in the following diagram.

When using a differential pressure sensor, the signal can be used for control purpose.

The K- factor is determined by comparative measurement on a standard test ring with non-disturbed air flow at suction.

RLM: (RLC E6) E6-/G6-/E3-	Calibration factor K10	RLM 56-/53-/55-	Calibration factor K10
-	-	2020	58 m^2s
-	-	2222	67 m^2s
2225 (G6)	73 m^2s	2525	77 m^2s
2528	79 m^2s	2528	73 m^2s
2831	94 m^2s	2831	90 m^2s
3135	106 m^2s	3135	105 m^2s
3540	128 m^2s	3540	120 m^2s
4045	155 m^2s	4045	150 m^2s
4550	190 m^2s	4550	190 m^2s
5056	242 m^2s	5056	240 m^2s
5663	310 m^2s	5663	300 m^2s
6371	385 m^2s	6371	385 m^2s
7180	490 m^2s	7180	485 m^2s
8090	628 m^2s	8090	620 m^2s
9010	794 m^2s	9010	790 m^2s
1011	1017 m^2s	1011	1000 m^2s
1112	1280 m^2s	1112	1260 m^2s
-	-	1214	1540 m^2s

Commissioning fans with frequency inverters

Instructions for fans with PM motors on external frequency inverters

We recommend inverters from the FC-100 range by Danfoss GmbH for operating fans with PM motors without integrated electronics.

In order to operate PM motors without position encoders, the rotors are brought into a defined starting position when starting up. Only then will the motor actually power up.

Note: Certain parameters are required for commissioning. Incorrect parameters can lead to problems in particular when starting the devices. It is not permitted to operate more than one of the permanent magnet motors with one frequency inverter. Updated parameter lists can be found at www.nicotra-gebhardt.com

Commissioning fans with integrated Danfoss FCP-106 frequency inverters

RLM fans with mounted Danfoss FCP-106 frequency inverters are pre-parameterized for activation via the analogue 0-10V input (terminals 52 (A IN) and 55 (COM A IN)). The enclosed product handbook describes the commissioning of the inverter in detail under "Quick Menu". The start is released by connecting terminals 12 ((+24V OUT) and 18 (DIG IN). If no other protection devices are to be connected to terminals 12 (+24V OUT) and 27 (DIG IN), these terminals must be bypassed.

If terminals 50 (+10V OUT) and 53 (A IN) are bypassed, the fan will run at its maximum speed. If required, a hardware reset can be carried out by temporarily bypassing terminals 12 (+24V OUT) and 19 (DIG IN).

Documentation on the FCP-106 frequency inverters can be found at [www.vlt-drives.danfoss.de/dokumentation/technische-literatur-\(datenbank\)/](http://www.vlt-drives.danfoss.de/dokumentation/technische-literatur-(datenbank)/)

Commissioning fans with integrated NI-DV inverters

Connection

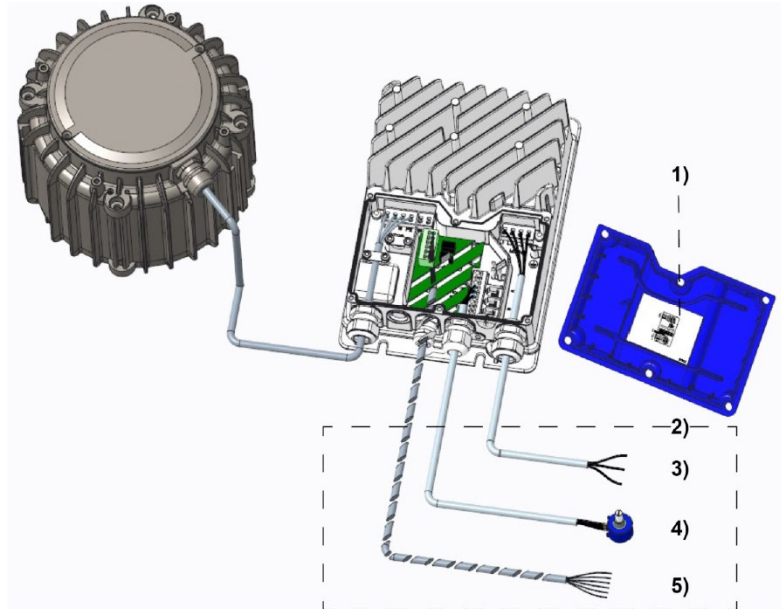

- 1) Circuit diagram
- 2) Connection options provided by the customer
- 3) Mains connection 230V/400V
- 4) Control option 2
- 5) Status output of optional accessories

Frequency inverter activation options

The control components shown are not available in part as accessories.

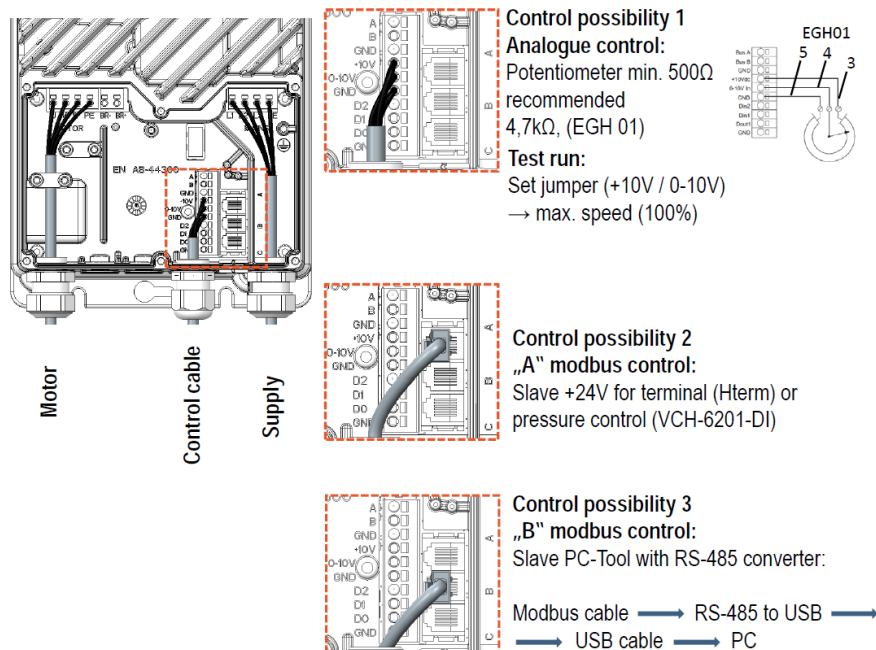

Maintenance

Plate Heat Exchangers

Only periodic visual checks are necessary. If dampers are fitted, test their movement. After initial 3- monthly inspection intervals, checks can be carried out every 12 months.

Based on long experience, dirt build up inside the heat plate exchangers installed in air handling equipment is not expected. Yet should dirt enter the plate heat exchanger when used for special applications, e.g. welding shops, paint shops, kitchen extracts etc., the heat exchanger package can be cleaned as follows.

Remove dust and fibres with a soft brush or with a vacuum cleaner. Take care when cleaning with compressed air that the exchanger package is not damaged. Keep at a distance.

Oils, solutions etc. can be removed with hot water or grease solvents, by washing or immersing. Cleaning with high pressure devices is possible if:

- A flat nozzle 40deg is used
- The maximum water pressure is 1000 bar

When cleaning take care that the heat exchanger is not damaged, neither mechanically or chemically:

- Choose harmless cleaning agents
- Clean carefully
- The material thickness is only 0.125 or 0.15mm!

“When cleaning take care that the exchanger is not damaged, neither mechanically nor chemically. You must choose harmless cleansing agents and ensure it is cleaned carefully.”

Lifting of the Fan Motor Lifting Beam

The fan lifting beam hoist consists of a permanent installed extending beam.

Use only a chain which fulfil the requirements of essential health and safety of European machine directive which are CE marked.

The purpose of the lifting beam is to lift the electrical motor or fan out of the air handling unit for replacement or overhaul.

Working Load Limit

The working load limit of the lifting beam is 300Kg.

Installation of Lifting Beam is Permanently Mounted

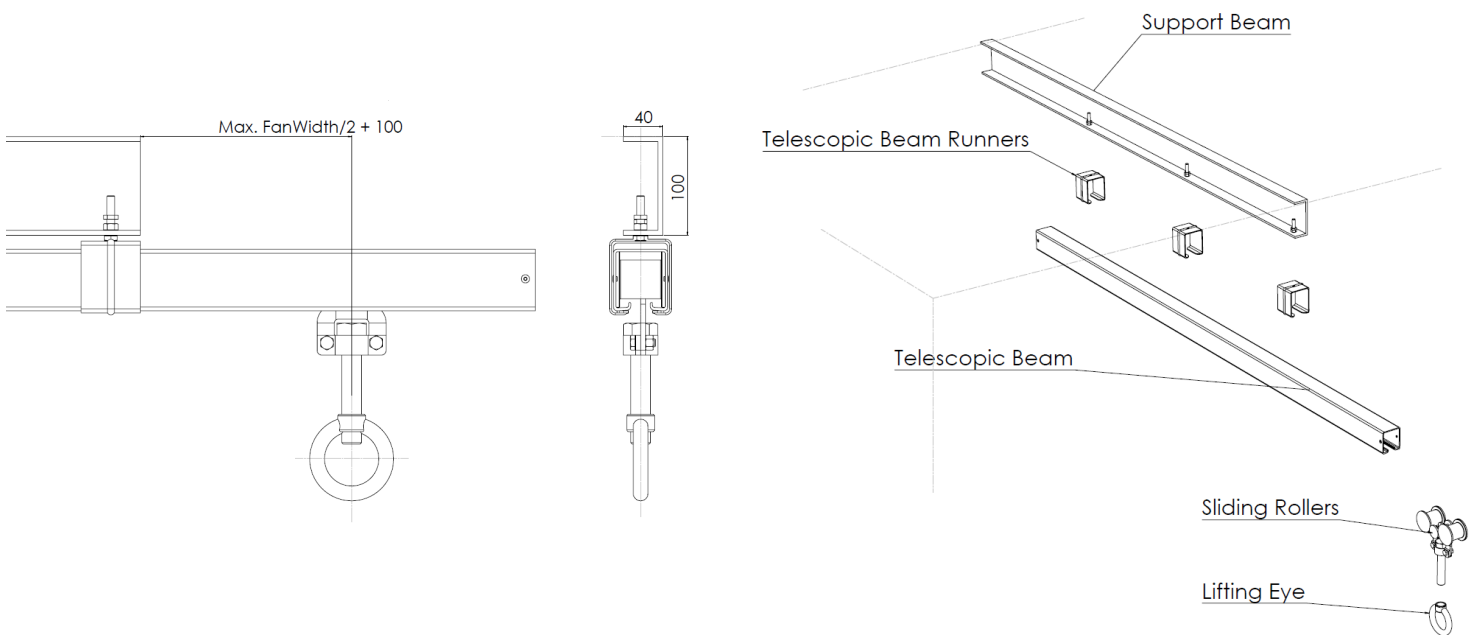

Operation

1. Place a pallet between the air handling unit and the support for transport of the motor.
2. Make sure that the main power is disconnected.
3. Manoeuvre the trolley over the motor and connect the lifting chain hook to the motor lifting points.
4. Free the motor from any mechanical and electrical connection, only qualified personal is allowed to disconnected the electrical power supply.
5. Lift the motor from the motor support.
6. Push the motor in direction of the lifting beam out of the air handling unit.
7. Stop the trolley in the middle of the extension beam.
8. Lower the motor onto the pallet and disconnect the chain hooks.
9. Reassembly takes place in the revered order.

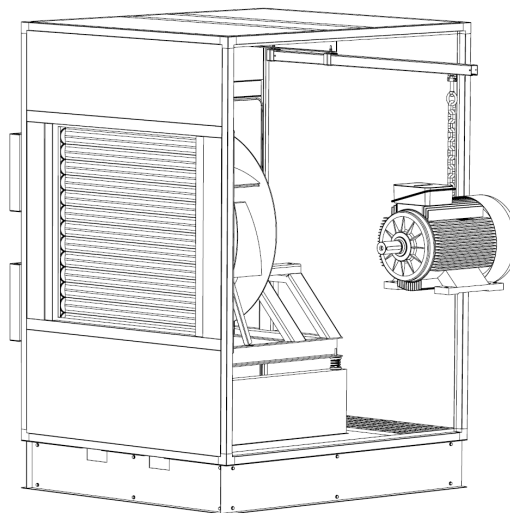

Checks Prior To Use

Prior to any use of the lifting beam, complete a visual check to make sure that no corrosion has occurred on the screw connection of lifting beam to air handling unit casing. If parts have to be replaced use original parts only by contacting ECE UK Limited.

Safety Instructions

1. Only personal who have read and understood this manual is allowed to operate the lifting beam.
2. Check the lifting beam equipment according to check prior to use.
3. Never use lifting beam equipment with more than working load limit marked on the equipment.
4. Prior use, follow the third party user manuals of trolley, lever hoist, lifting chain, motor and fan.
5. Do not use the lifting beam equipment for lift of personal, the lifting beam equipment is for lift of electrical fan motor only.
6. Always wear protective gear as e.g. helmet, protective shoes.
7. Work in safety distance to the lifted load and lifting beam equipment.
8. Check with water-level the horizontal position of the lifting beam.
9. Do not have unwatched load hanging on the lifting beam.
10. Two persons are required to install and operated the lifting beam safely.

The lifting beam is for manual operation only

RLM Fan Maintenance

Safety Notes

Before working on the fan it is imperative to ensure:



- All poles of the drives and motors are disconnected from the grid!
- The impeller has come to rest!
- The surface temperature has been checked to prevent burning!
- There is no possibility of an uncontrolled running of the fan during the maintenance work (e.g. through an isolating switch)!

Caution: electric shock!

There is electrical voltage in the intermediate circuit of the control electronics and the grid connections when the permanent magnet motor turns!



- Do not do any work on the fan while the impeller/motor is rotating freely
- Lock the impeller by suitable means
- Any debris or dangerous materials which have arrived in the fan with the transported medium must be removed using a suitable method.

Fan operation may resume after the safety checks of Section 6 “Commissioning / Safety checks” have been carried out.

Only limited work may be carried out while in the operating condition and in observance of the safety and accident prevention regulations: e.g. measurement of vibration.



Non-observance of these points endangers life and limb for the maintenance personnel.

CAUTION

If the state of the fan does not allow adapted action for repair it has to be put out of order immediately and to be replaced if required!

Inspection Intervals

After having passed the period during which the grease keeps its lubrication capacity (30.000 h for standard applications) an bearing exchange may be required. During periods of longer lasting stand stills the fan may be operated shortly in regular intervals. This is to prevent the bearings from mechanical load and the avoid ingress of humidity. If fans have been hold on stock for a longer period the bearings of fan and motor have to be checked prior to installation.

Motors are equipped with permanently lubricated or re greaseable bearings, depending on the manufacturer, size and type of motor. Grease leakage cannot be excluded for motors with re greaseable bearings, even after the initial filling at the factory. However, this does not have a negative effect on the life of the bearings; regreasing intervals must be adhered to.



Ensure that the motor manufacturer's maintenance specifications as well as information provided by the manufacturer for the switches and control units as well as the frequency inverter are observed.

In order to assure a safe operation we recommend to make checks of the fans in regular intervals by specialised service personnel or by a specialised company and to document the result of these checks.

The type, magnitude, and interval period as well as all works which may be necessary in addition depend on the use and the surrounding conditions of the fan and have to be determined case by case.

CAUTION

No high pressure cleaners (steam rod cleaners) are to be used!

Vibrations

The fan has be checked regularly whether vibrations may occur. The maximum vibration speed in radial direction must not exceed 4.5 mm/s to monitored at the bearing or bearing housing of the fan or motor. For fans of a impeller diameter up to 315 mm a vibration speed of up to 7.1 mm/s is acceptable. When exceeding the permitted vibration values, it is mandatory to rebalance the entire rotating unit in accordance with DIN ISO 21940-11.

Dismantling of the impeller

After dismantling and reinstalling an impeller, the fan must be checked for mechanical vibrations. It may be necessary to rebalance.

Inlet and discharge connections

Flexible sleeving (compensators) between the fan and plant parts are to be checked at regular intervals.

CAUTION

Unsealed sleeving leads to breakdowns and danger from escaping transported medium and must be replaced.

Faults

Deviations from normal operating conditions always lead to functional breakdowns and should be looked for immediately by maintenance personnel.



Longer lasting faults can result in the destruction of the fan and give rise to damage in plant parts and injuries to personnel!

In the event that the maintenance personnel cannot eliminate the fault, please make contact with our mobile customer service.

Disposal of the product

Used product shall be disposed or recycled according to the local laws and regulations.

Maintenance Schedule

Item	Interval (in months)					
	1	2	3	4	6	12
SISW / DIDW Fans:						
Fan impeller cleaning				✓		
Fan motor – cooling vents clear, bearings check			✓			
Fan vee-belt drive, wear, tension, alignment		✓				
Plug Fans:						
Check and lubricate the motor						✓
Clean the impeller using a vacuum cleaner, compressed air or by brushing. Greasy dirt can be washed with detergent or a solvent						✓
Filters:						
Filter panels check, clean or renew as necessary	✓					
Filter bag check, clean or renew as necessary:						
➤ Standard			✓			
➤ Fine		✓				
➤ Extra fine		✓				
Filter absolute and activated carbon check, clean or renew as necessary	✓					
Coils:						
Coils venting		✓				
Coils surfaces, connecting piping			✓			
Electric Air Heater Battery:						
EAHBs continuity, earthing, HT cut out			✓			
Wiring, flow switch, fan overrun, controls			✓			
Dampers:						
Bearings, links, free movement			✓			
Motors, bearings, free movement			✓			

Gas Burners						
All points			✓			
Humidifiers:						
Humidifier cylinder electrodes	✓					
Humidifier controls, wiring, piping			✓			
General Maintenance:						
Metal, paint, sealing strips, sealant, fixings				✓		
Insulation, AVs, flex, connections, fixings			✓			
Wiring, controls, earth continuity			✓			

* indicates a one-off activity

This Schedule is not intended to be exclusive, inclusive or mandatory. Different conditions of use may dictate shorter or longer periods and or more intensive action.

SISW / DIDW - Fan Bearings

Spider Arm Bearing

Sealed ball races mounted in rubber, pre-greased and self-aligning for service free use under normal duties.

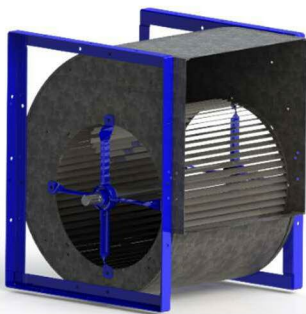
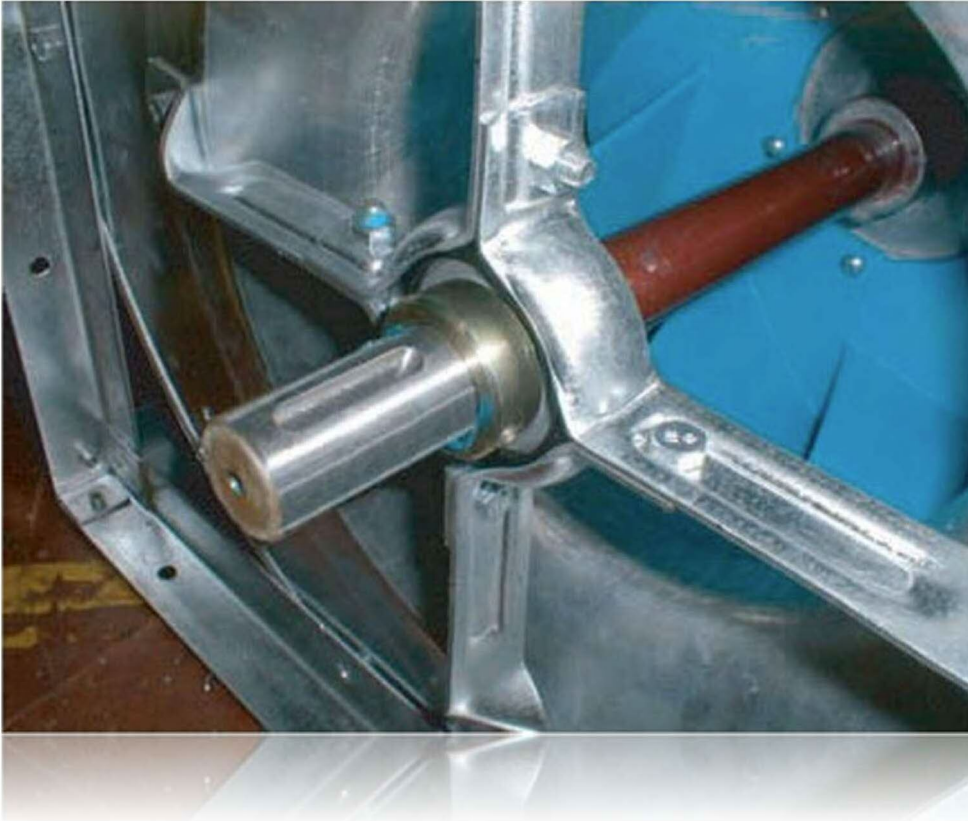

TL3 up to 400 and TL3 450-630

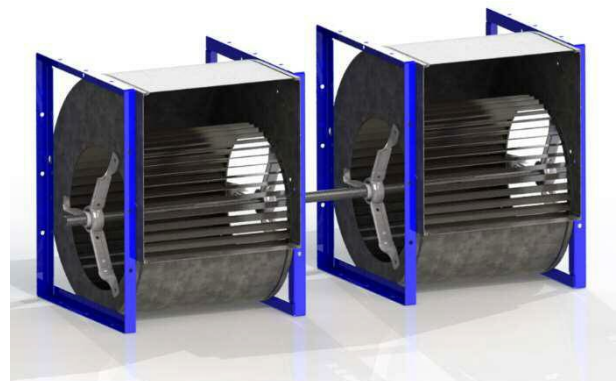

THLZ Duplex – 3 No. spider arm bearings

Units in the ECE range fitted with spider arm bearings

Plummer Block Bearing

Sealed ball races, mounted in cast iron supports, self-aligning and pre-greased with grease points.



Extended shaft 'A' frame



NTH3 T1 and T2 710 – 1000

Units in the ECE range fitted with Pillow Block bearings

Replacing the filters (for HTM specification units)

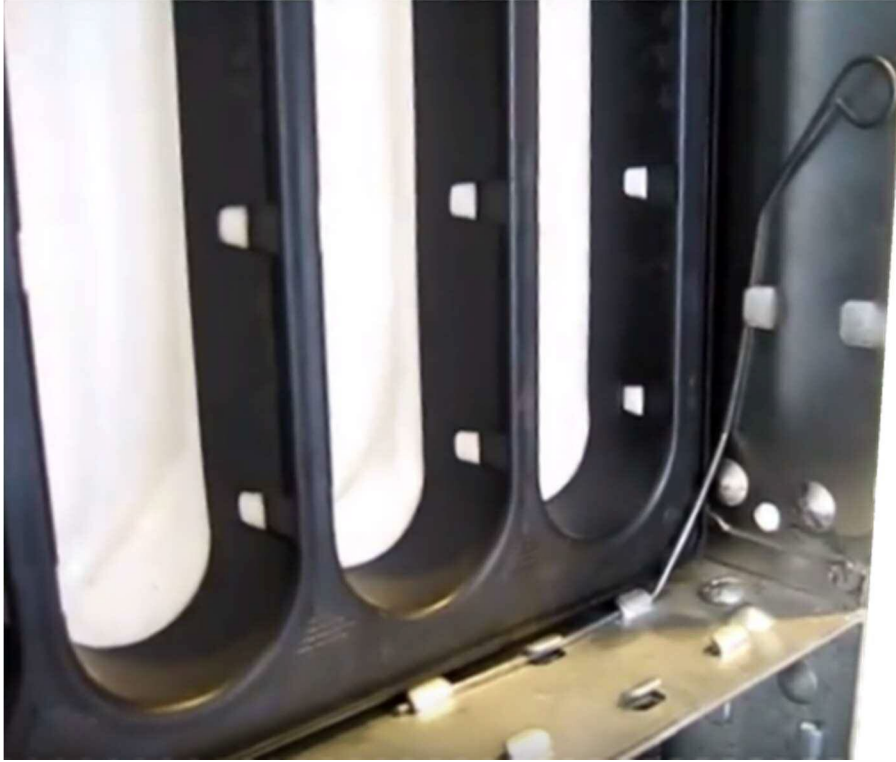

All filters are fitted to universal filter frames. The filters are fixed using C70 clips. To replace a filter:

- Unclip the fastening pins and pivot them in their base

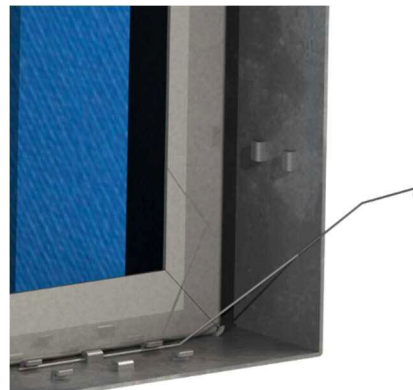

- Once all the clips are loosened the filter will start to come out from the top. Pull the filter out and check neoprene tape for damage, replacing as required

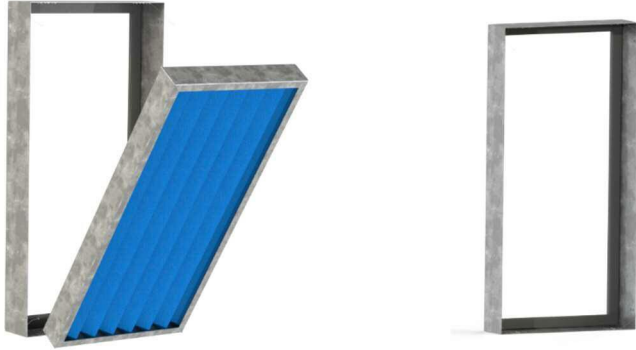

- Push the new filter into the frame, making sure the pleats are all vertical and the filter seals against the neoprene tape

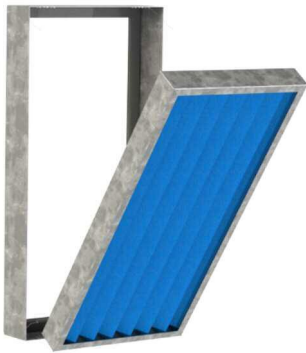

- Re-fasten the C70 pins

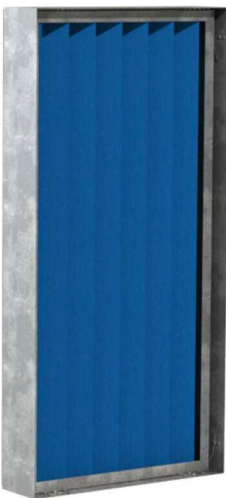

Motor Bearings

Self-aligning self-oiling and spring loaded ball lubricators, use light machine oil.

Pressure grease fittings and relief plugs, wipe down fitting, remove pressure plug (if fitted) and hardened grease. Add grease till NEW grease is expelled, run motor for 10 minutes, stop motor, clean and replace plus.

The bearing should be repacked with Shell Alvania 2, BP Energygrease 2 or Esso Beacon 2, leaving room for expansion (These greases are suitable for temperatures between -30 C and + 110C).

If a rumble, knock or scrape is heard the motor should be replaced or examined and repaired by an electric motor repair specialist.

NEVER subject the shaft to hard blows, as this may cause damage to the bearings resulting in noisy running and reduce list.

Motors without Grease Points

Remove belts, run motor and apply the tip of a screwdriver to motor body (not shaft!) and the handle to your ear. A purring sound should be heard. If a squeaking noise is heard the bearing is dry and should be cleaned and flushed, out with a mixture of Tuoline and methylated alcohol (or, in an emergency, white spirit, never petroleum or paraffin).

Motor Overheating

Check for overheating, ascertain cause and rectify.

Washable Filters

Wash in mild detergent, rinse and squeeze dry.

Activated Carbon (Constantly Monitored)

When gas absorption drops below limiting level remove, replace with spare set and sent laden set for reactivation of discard.

Activated Carbon (disposable non-monitored)

After 1 month usage remove test element or one cell (install new cell) and send for analysis and prediction of remaining life. Replace filters completely within predicted period.

Electric Heater Batteries

Particularly check condition of wiring and insulation, plus surrounding paintwork/metalwork for signs of overheating.

Dampers - Motors

Lightly oil damper and motor bearings and link swivels – except nylon bearings.

Coils - General

Check finned surfaces every six months for build-up of dirt or lint. If required wash down with mild detergent solution and soft brush and blow out any solids between fins with compressed air line. Take care not to disturb the fin surfaces or probe the coils with metal scraper as damage may cause leaks.

At six monthly intervals ensure that the condensate drain lines are unobstructed and functioning.

DX Cooling Coils

During winter the refrigerant should be pumped over into the liquid receiver and the isolating valve shut. Enough gas should be left in the system to keep a positive pressure in it. Before restarting, the plant should be checked for refrigerant leaks.

Fault Finding

Centrifugal Fans

Fault	Check
NO AIR FLOW ➤ Fan motor stationery ➤ No current to motor	<ul style="list-style-type: none"> ✓ Motor connected ✓ Wiring or isolator (on?) ✓ Fuses intact ✓ Wiring to starter (on?) ✓ Starter wired properly ✓ Overloads holding in and correct size ✓ Wiring to time clock at "on phase" ✓ Wiring to panel/mains (on?) ✓ Other control circuits holding fan(s) off (eg. gas fired heater warm up)
NO AIR FLOW ➤ Fan motor running ➤ Current to motor	<ul style="list-style-type: none"> ✓ Jammed impeller ✓ Seized fan/motor bearings ✓ Drive belts too tight ✓ Motor windings/wiring faulty ✓ Motor wrongly connected ✓ Wrong voltage
NO AIR FLOW ➤ Fan motor running ➤ Fan stationery	<ul style="list-style-type: none"> ✓ Jammed impeller ✓ Drive belts loose or missing ✓ Impeller loose or missing
NO AIR FLOW ➤ Fan running	<ul style="list-style-type: none"> ✓ Louvres blocked ✓ VCD's closed ✓ Filters blocked ✓ Cooling coil frozen solid ✓ Duct blocked ✓ Fire damper link failed ✓ Grilles closed
LOW AIR FLOW	Check as for no air flow plus:- <ul style="list-style-type: none"> ✓ Fan rotation incorrect ✓ Filters back to front ✓ Media wrong ✓ Drive belts slack or greasy ✓ Pulley ratios wrong ✓ Duct resistance exceeds design ✓ Duct leaking on pressure side ✓ Access doors off ✓ Duct joint not sealed
HIGH AIR FLOW	<ul style="list-style-type: none"> ✓ Low initial clean filter resistance ✓ Filter missing ✓ Duct incomplete or leaking ✓ Pulley ratios wrong ✓ Backward bladed impeller installed as forward ✓ System resistance over estimated
MOTOR CURRENT EXCEEDS NAMEPLATE F.L.C.	Check as for no airflow, low air flow, high air flow

Electric Heaters

Fault	Check
NO HEAT	<ul style="list-style-type: none"> ✓ All controls, protective devices and interlocks as described in "Commissioning" section are installed ✓ Thermostat setting too low ✓ Time clock at "on" phase ✓ Filters clean ✓ Airflow adequate ✓ Isolator connected ✓ Mains switch on ✓ Power from mains ✓ All wiring connected ✓ High temperature cut out button in ✓ Continuity across H.T. cut out terminals ✓ Airflow switch making and breaking ✓ Voltage to airflow switch terminals ✓ Contactor coil functioning properly ✓ Fuses not blown ✓ Step controller functioning properly ✓ Fan - EAHB interlock functioning properly <p>If low airflow refer to "Low Airflow" centrifugal fan section.</p> <p style="text-align: center;"><i>If the high temperature cut out has operated do not run system until reason for "cut out" has been found.</i></p>
LOW HEAT	<ul style="list-style-type: none"> ✓ Wrong elements supplied ✓ Element failure (open circuit or down to earth) ✓ Elements disconnected ✓ Elements incorrectly wired ✓ Wrong voltage ✓ Thermostat too low ✓ Step controller sticking/faulty ✓ Wiring fault ✓ Other controller equipment fault

Cooling Coils

Fault	Check
NO COOLING ➤ Current to plant	<ul style="list-style-type: none"> ✓ Thermostat setting too high/faulty ✓ Time clock at "on" phase ✓ Motor not connected ✓ Overloads tripped ✓ (continue checks as for airflow in "fans")
NO COOLING ➤ HP cut out functioning	<ul style="list-style-type: none"> ✓ Correct setting ✓ Faulty condenser ✓ Heat rejection faulty ✓ Fans and pumps stopped ✓ Condenser blocked
LOW OR NO COOLING ➤ LP cut out functioning	<ul style="list-style-type: none"> ✓ Suction pressure/evaporating temperature too low ✓ Coil freezing up ✓ Condenser too large for evaporator ✓ Low air flow ✓ Uneven air flow ✓ Low entering air temperature ✓ Humidistat(s) calling for dehumidification

	<ul style="list-style-type: none"> ✓ Low compressor capacity control installed and functioning
NO COOLING ➤ Chilled water isolating valve closed	<ul style="list-style-type: none"> ✓ Thermostatic valves closed ✓ Thermostat failure ✓ Circulating pump failure
NO COOLING ➤ LP cutout functioning ➤ Expansion valve freezing	<ul style="list-style-type: none"> ✓ Water in system
LOW COOLING ➤ Fridge plant cycles	<ul style="list-style-type: none"> ✓ Low load (unloader) compressor capacity control functioning ✓ Step controller functioning ✓ Other modulating controls functioning
HIGH RH	<ul style="list-style-type: none"> ✓ Humidistat or dewpoint stat too high / faulty ✓ No cooling ✓ Coil fault (see above) ✓ Entering air temperature too high ✓ Insufficient cooling capacity (maybe start up, pull down time) ✓ Excessive fresh air or airflow ✓ Excessive moisture gain ✓ Moisture carryover
LOW RH	<ul style="list-style-type: none"> ✓ Stat too low / faulty ✓ Coolant too cold ✓ Refrigerant plant capacity too high ✓ Inadequate controls ✓ Insufficient air flow
COIL SWEATING	<ul style="list-style-type: none"> ✓ Blocked filters ✓ Blocked coil face ✓ Air on dewpoint condition higher than design ✓ Chilled water flow temperature or DX evaporating temperature lower than design
MOISTURE CARRY OVER FROM FINS (or past eliminators if fitted)	<ul style="list-style-type: none"> ✓ Check as for "coil sweating" ✓ High volume ✓ Uneven face velocity ✓ Eliminators omitted in error
MOISTURE CARRY OVER FROM DRAIN TRAY (or drain tray not emptying or leaking)	<ul style="list-style-type: none"> ✓ Horizontal ✓ Undamaged ✓ Drain tray outlet to U-trap not clogged ✓ Primed adequate differential U-trap drain ✓ Adequately sized correctly pitched condense line dropping into open tundish ✓ Upstream restricted airflow causing depression at coil greater than U bend differential ✓ Cover plates leaking air on bolt on coils

Heating Coils

Fault	Check
NO HEAT	<ul style="list-style-type: none"> ✓ Thermostat too low/faulty ✓ Time clock at "on" phase/faulty ✓ Pump failure ✓ Boiler plant off ✓ Automatic valve closed due to thermostat ✓ Valve transformer failure ✓ Isolating valves closed ✓ Airlock
LOW HEAT	<ul style="list-style-type: none"> ✓ Check flow and return temperature - if low check boiler plant and controls ✓ Check flow rate – if low check:- ✓ Regulating valves open ✓ Insufficient pump head ✓ Piping sizing wrong ✓ Blockage in coil or high coil resistance (check temperature change across coil and equal tube temperatures). ✓ Warm up time adequate

Refrigeration

Fault	Check
HEAD PRESSURE TOO HIGH	<ul style="list-style-type: none"> ✓ Refrigerant overcharge - vent excess charge ✓ Air in system - leak test, repair leak, evacuate and recharge ✓ Dirty Condenser - clean ✓ Malfunction of condenser fan (air cooled) - check head pressure speed control if fitted ✓ Restricted water flow - check flow rate and adjust ✓ Water on temperature too high - cooling tower operation ✓ Blockage in discharge pipe work - check and replace damaged section(s) evacuate and recharge ✓ High air temperature entering condenser (air cooled) spill over between adjacent condenser, fit baffle or re-site condensers
LOW HEAD PRESSURE	<ul style="list-style-type: none"> ✓ Refrigerant under charge - leak test, add refrigerant if necessary ✓ Over condensing - Fan speed too high (air cooled), water flow too high (water cooled) ✓ Faulty valves ✓ Low external ambient - pre heat air to cooled condenser ✓ Low back pressure
HIGH BACK PRESSURE	<ul style="list-style-type: none"> ✓ Air flow too high – adjust belt drive as necessary ✓ Room temperature or air on too high – adjust thermostat ✓ Faulty expansion valve ✓ Also see– "Head pressure too high" above
LOW BACK PRESSURE	<ul style="list-style-type: none"> ✓ Air flow too low – adjust belt drive as ✓ Filters dirty ✓ Shortage of refrigerant – leak test add refrigerant as necessary ✓ Faulty valves ✓ Blockage in pipe check and replace damaged section(s) evaluate and recharge
SUCTION LINE SWEATING BACK TO COMPRESSOR	Expansion valve open too wide

Fan Drive Belts

		PROBLEM																	
		Loose cover & swell	Weathering or 'Craze' cracks	Gouges	Stalling	Envelope wear	Uneven envelope wear	Ply separation	Side split	Broken belts	Belts turn over	Hardening / premature cracking	Squeal	Excessive stretch	Vibration	Belts too long at installation	Belts too short at installation	Mismatched belts at installation	
PROBABLE CAUSES	Excessive oil	●																	
	Exposure to elements	●																	
	Belt forced over pulley rim		●																
	Contact with obstruction			●															
	Insufficient tension				●									●					
	Stalled driven pulley				●														
	Excessive slip					●													
	Rough pulleys						●												
	Substandard pulleys							●	●										
	Excessive tension									●									
	Shock load										●			●					
	Foreign material										●								
	Excessive dust						●												
	Drive misalignment										●								
	Worn pulley grooves											●						●	
	Excessive vibration												●						
	High ambient temperature											●							
	Excessive tension													●					
	Drive underbelted														●				
	Damaged tensile member															●			
	Incorrect belts																●	●	
	Incorrect drive set up																●	●	
	Insufficient take up																●	●	
	Improper matching																	●	
Mixed old and new belts																	●		
Non parallel shafts																	●		
Different manufacturers																	●		
REMEDY	Lubricate properly	●			●														
	Clean pulleys & belt(s)	●																	
	Replace belt(s)		●											●				●	
	Provide protection		●			●				●									
	Install properly			●										●					
	Check for belt length			●															
	Remove obstruction			●															
	Tension properly				●	●							●	●	●				
	Free pulleys					●													
	Replace pulleys						●				●							●	
	File smooth							●											
	Redesign drive								●	●									
	Operate properly											●							
	Align drive												●					●	
	Provide ventilation													●					
	Check for proper belt(s)														●		●	●	
	Check machinery															●	●	●	
	Use only new belts																		●
	Use single source																		●